

WARNING: READ THE ASSEMBLING INSTRUCTIONS CAREFULLY BEFORE ASSEMBLING THE EYZEAT INGROUND BENCH SEAT ONLY.

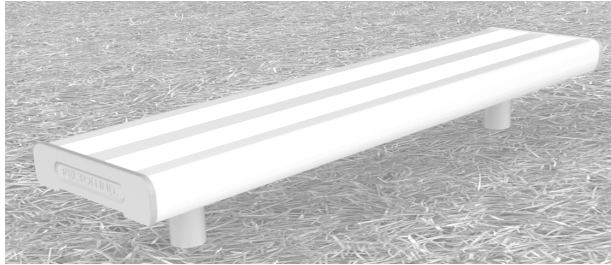



Make sure to wear protective gloves and foot protection when installing and assembling this product. Unpack the unit and make sure all the components are included before proceeding. This activity requires two or more people as lifting is involved. Please ensure bolts are only finger-tightened during the assembling process for flexibility in lining up components. Securely tighten the bolts before anchoring the product to the ground.





**1m. EYZEAT INGROUND GROUND BENCH SEAT
(CODE No. EZYJIG1)**

ITEM PART	DESCRIPTION	QTY
EJIG1	SEAT LEG	2
EJIG2	1000 mm.—SEAT ALUMINIUM PLANK	1
EJIG3	M6x25 mm. HEXAGONAL HEAD BOLT	8
EJIG4	M6 LOCKNUT	8

EJIG1

EJIG2

EJIG3



EJIG4

Thank you for purchasing our high quality products. The Ezyseat InGround Bench Seat has been well manufactured with certified materials, to achieve high reliability and minimum maintenance. It is our commitment to provide you cost-effective solutions for outdoor applications.

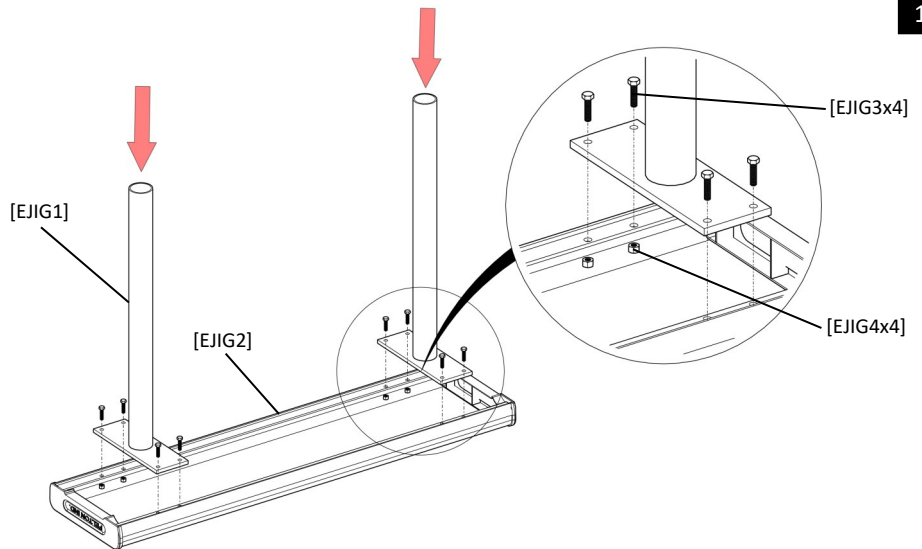

1

Place the seating plank (EJIG2) up side down on a flat surface and attached it to the frames (EJIG1), by using hex. head bolts (EJIG3) and locknuts (EJIG4) — finger tighten.



2

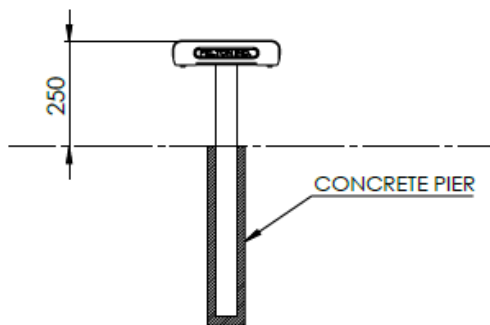

FRONT VIEW

Adjust all bolts properly with a span, wrench and/or any appropriate tool. Turn the bench seat up and fix it to the ground, by pouring concrete (Concrete piers).

The recommended seat height for 2-4 years infants is 250 mm. (from the ground level to top seat plank as shown in the illustration).

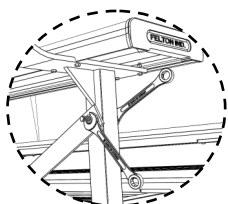
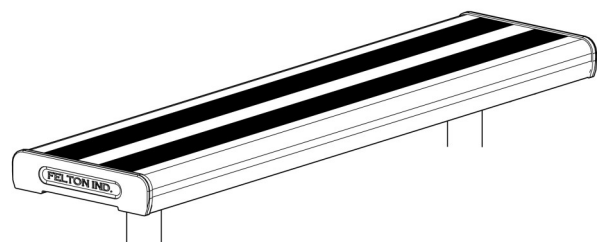

1