

WARNING: READ THE ASSEMBLING INSTRUCTIONS CAREFULLY BEFORE ASSEMBLING THE ABOVE GROUND BENCH SEAT WITH BACK REST.



Make sure to wear protective gloves and foot protection when installing and assembling this product. Unpack the unit and make sure all the components are included before proceeding. This activity requires two or more people as lifting is involved. Please ensure bolts are only finger-tightened during the assembling process for flexibility in lining up components. Securely tighten the bolts before anchoring the product to the ground.



**2m.— ABOVE GROUND BENCH SEAT WITH BACK REST
(CODE No. FELAGB2)**

ITEM PART	DESCRIPTION	QTY
AGBR1	SEAT FRAME	2
AGBR2	2000 mm.—SEAT ALUMINIUM PLANK	1
AGBR3	2000 mm.—ALUMINIUM BACK REST	1
AGBR4	M6x25mm. HEXAGONAL HEAD BOLT	12
AGBR5	M6 LOCKNUT	12

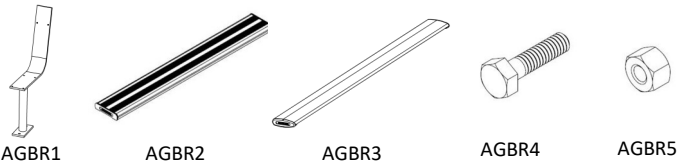

Thank you for purchasing our high quality products. The Above Ground Bench Seat with Back Rest has been well manufactured with certified materials, to achieve high reliability and minimum maintenance. It is our commitment to provide you cost-effective solutions for outdoor applications.

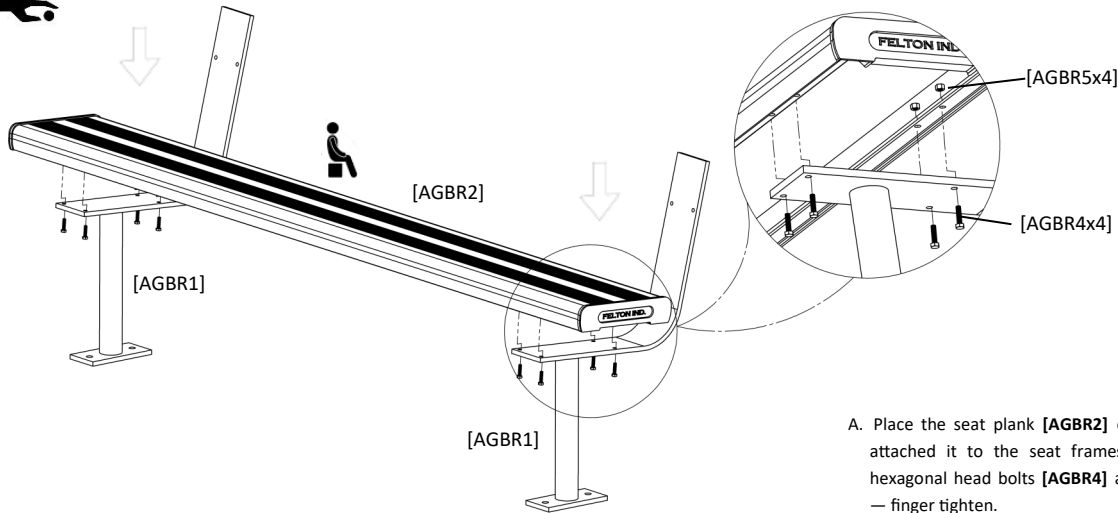

1

A. Place the seat plank [AGBR2] on a flat surface and attached it to the seat frames [AGBR1], by using hexagonal head bolts [AGBR4] and locknuts [AGBR5] — finger tighten.

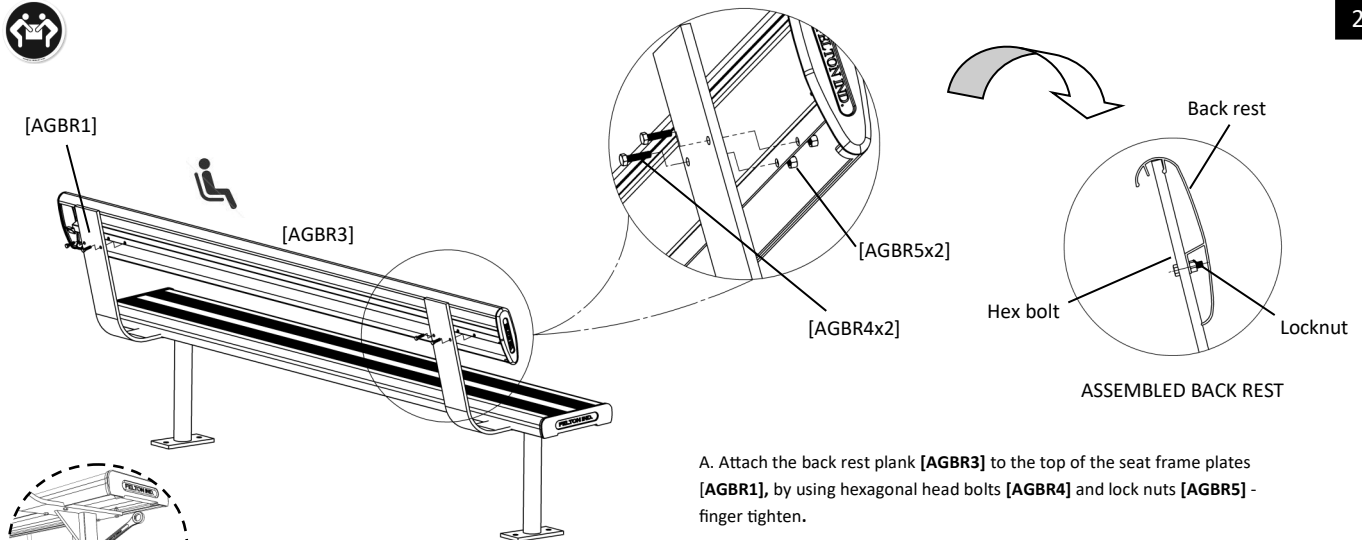

2

A. Attach the back rest plank [AGBR3] to the top of the seat frame plates [AGBR1], by using hexagonal head bolts [AGBR4] and lock nuts [AGBR5] - finger tighten.

B. Tight both, the back rest and seat bolts with spans, wrench and /or a proper tool.

P1