

WARNING: READ THE ASSEMBLING INSTRUCTIONS CAREFULLY BEFORE ASSEMBLING THE BUDDY BENCH.

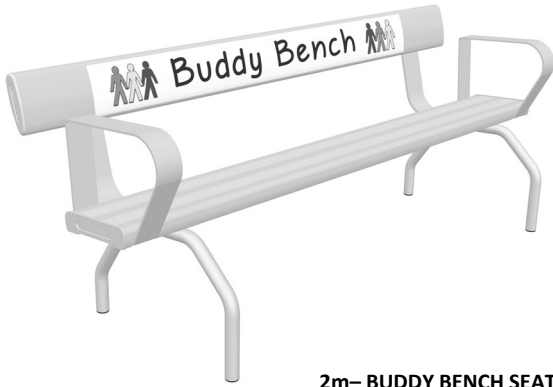

Make sure to wear protective gloves and foot protection when installing and assembling this product. Unpack the unit and make sure all the components are included before proceeding. This activity requires two or more people as lifting is involved. Please ensure bolts are only finger-tightened during the assembling process for flexibility in lining up components. Securely tighten the bolts before anchoring the product to the ground.



**2m- BUDDY BENCH SEAT
(CODE No. PSFSB2-BB)**

ITEM PART	DESCRIPTION	QTY
PSFBB1	SEAT FRAME	2
PSFBB2	2000 mm.—SEAT ALUMINIUM PLANK	1
PSFBB3	2000 mm.—ALUMINIUM BACK REST	1
PSFBB4	ARM REST—ALUMINIUM	2
PSFBB5	M6X25mm. HEXAGONAL HEAD BOLT	12
PSFBB6	M6 LOCKNUT	12

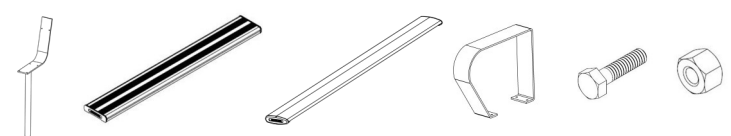

PSFBB1 PSFBB2 PSFBSB3 PSFBSB4 PSFBB5 PSFBB6

Thank you for purchasing our high quality products. The Free Standing Bench Seat with Back Rest has been well manufactured with certified materials, to achieve high reliability and minimum maintenance. It is our commitment to provide you cost-effective solutions for outdoor applications.



1

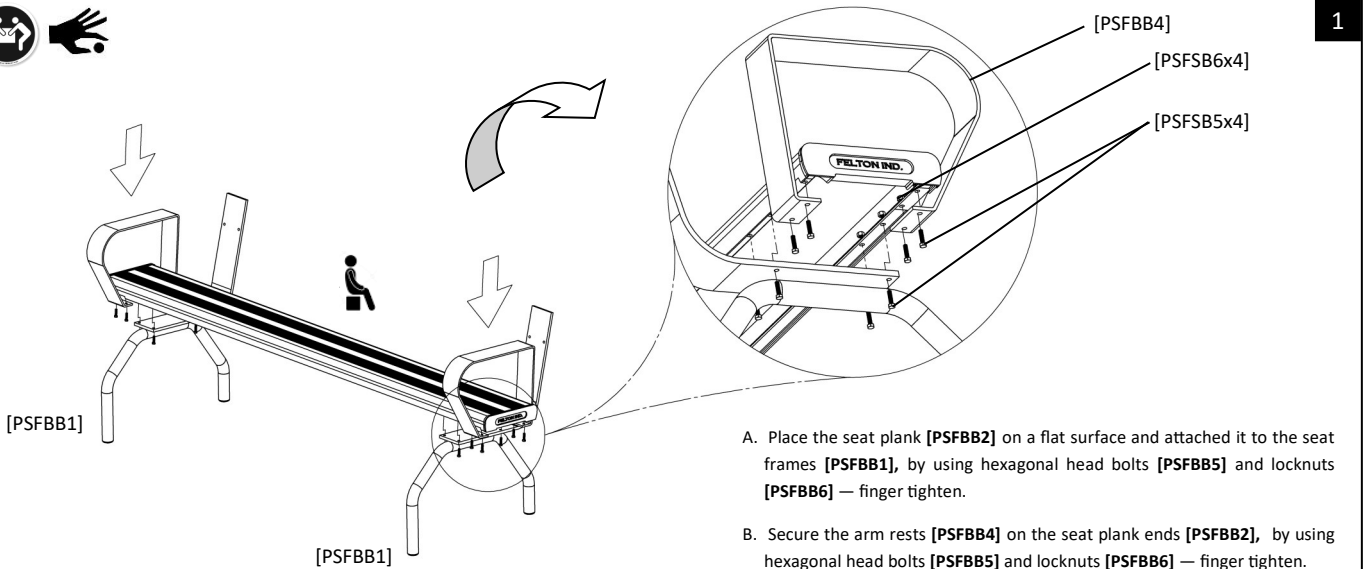

A. Place the seat plank [PSFBB2] on a flat surface and attached it to the seat frames [PSFBB1], by using hexagonal head bolts [PSFBB5] and locknuts [PSFBB6] — finger tighten.

B. Secure the arm rests [PSFBB4] on the seat plank ends [PSFBB2], by using hexagonal head bolts [PSFBB5] and locknuts [PSFBB6] — finger tighten.



2

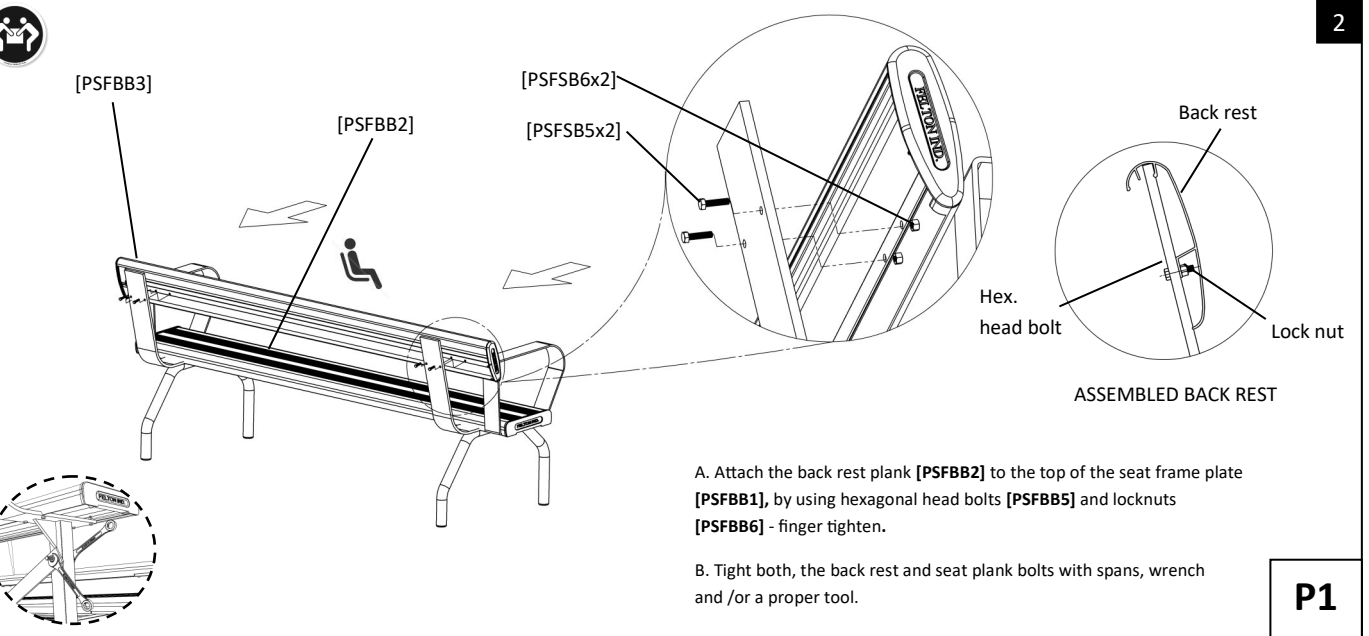

A. Attach the back rest plank [PSFBB3] to the top of the seat frame plate [PSFBB2], by using hexagonal head bolts [PSFBB5] and locknuts [PSFBB6] - finger tighten.

B. Tight both, the back rest and seat plank bolts with spans, wrench and /or a proper tool.