

WARNING: READ THE ASSEMBLING INSTRUCTIONS CAREFULLY BEFORE ASSEMBLING THE DOUBLE PLANK SEATING.



Make sure to wear protective gloves and foot protection when installing and assembling this product. Unpack the unit and make sure all the components are included before proceeding. This activity requires two or more people as lifting is involved. Please ensure bolts are only finger-tightened during the assembling process for flexibility in lining up components. Securely tighten the bolts before anchoring the product to the ground.



DOUBLE PLANK x2 m. SEATING.
(Code No: FELGCR12)

PART No.	PART NAME	QTY
GDR1	ALUMINIUM FRAME	2
GDR2	2000- mm. ALUMINIUM FOOT/ SEATING PLANK	2
GDR3	M6 X25 mm. HEXAGONAL HEAD BOLT	16
GDR4	M6 LOCKNUT	16



[GDR1]



[GDR2]



[GDR3]



[GDR4]

Thank you for purchasing our high quality products. The Double Plank Seating has been well manufactured with certified materials, to achieve high reliability and minimum maintenance. It is our commitment to provide you cost-effective solutions for outdoor applications.

1

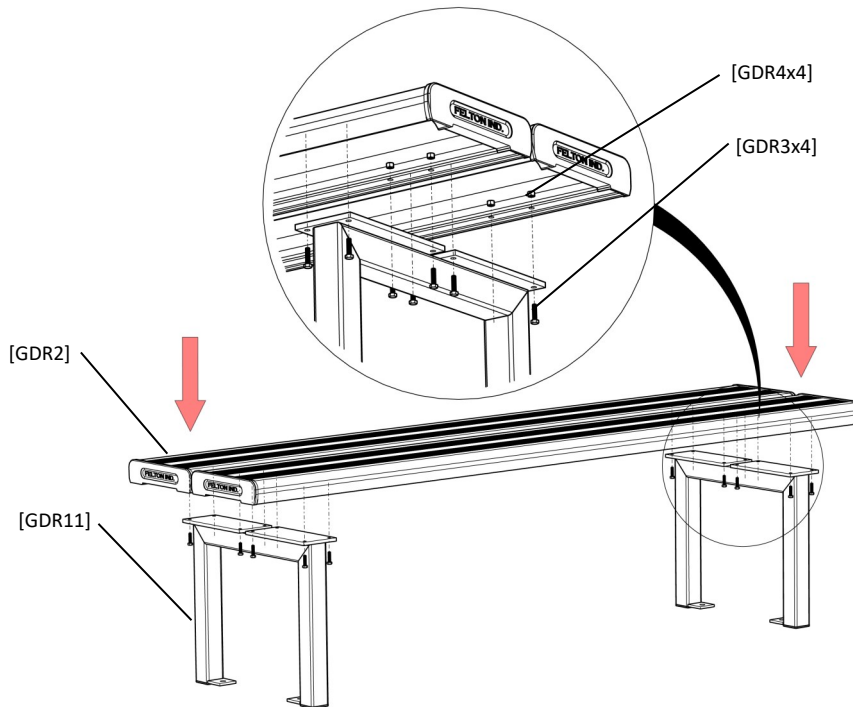

- A. Have the two Aluminium frames [GDR1] up with bolt down lugs facing ground.
- B. Place the seating planks [GDR2] onto top frames [GDR1] and secure them with hex. head bolts [GDR3] and locknuts [GDR4] - finger tighten.

2

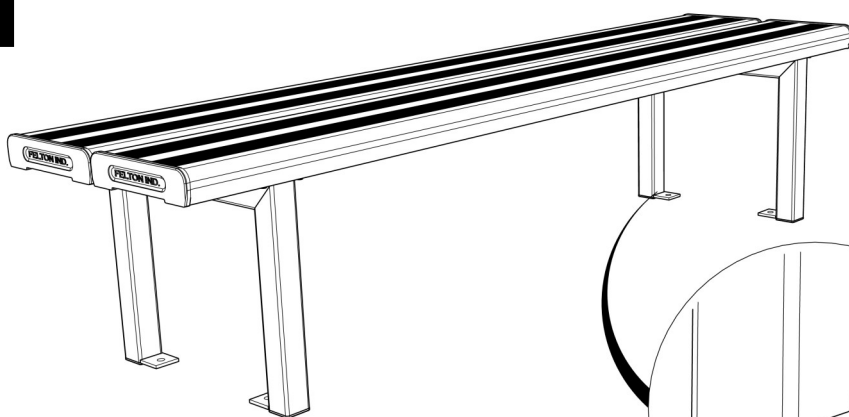

- 5. Tight the whole structure with spanners and appropriate tools.
- 6. Locate the Double plank seating on firm level ground.

