

WARNING: READ THE ASSEMBLING INSTRUCTIONS CAREFULLY BEFORE ASSEMBLING THE FREE STANDING BENCH SEAT ONLY.

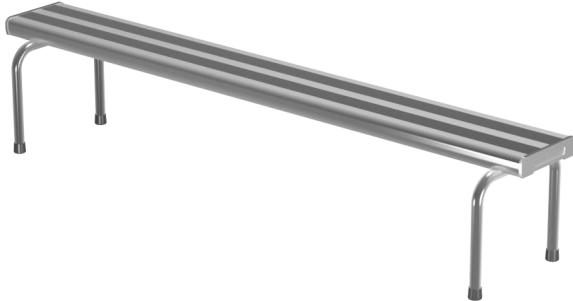



Make sure to wear protective gloves and foot protection when installing and assembling this product. Unpack the unit and make sure all the components are included before proceeding. This activity requires two or more people as lifting is involved. Please ensure bolts are only finger-tightened during the assembling process for flexibility in lining up components. Securely tighten the bolts before anchoring the product to the ground.



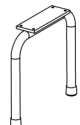

2m- FREE STANDING BENCH SEAT ONLY
(CODE No. FELFSS2)

ITEM PART	DESCRIPTION	QTY
FSS1	SEAT FRAME	2
FSS2	2000 mm.—SEAT ALUMINIUM PLANK	1
FSS3	M6x25mm. HEXAGONAL HEAD BOLT	8
FSS4	M6 LOCKNUT	8



FSS1

FSS2

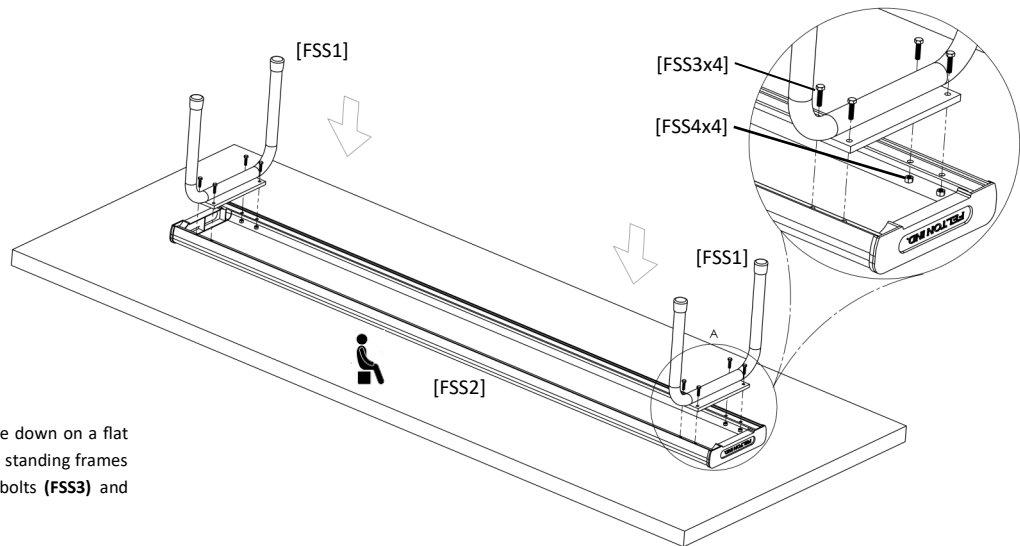

FSS3

FSS4

Thank you for purchasing our high quality products. The Free standing Bench Seat has been well manufactured with certified materials, to achieve high reliability and minimum maintenance. It is our commitment to provide you cost-effective solutions for outdoor applications.

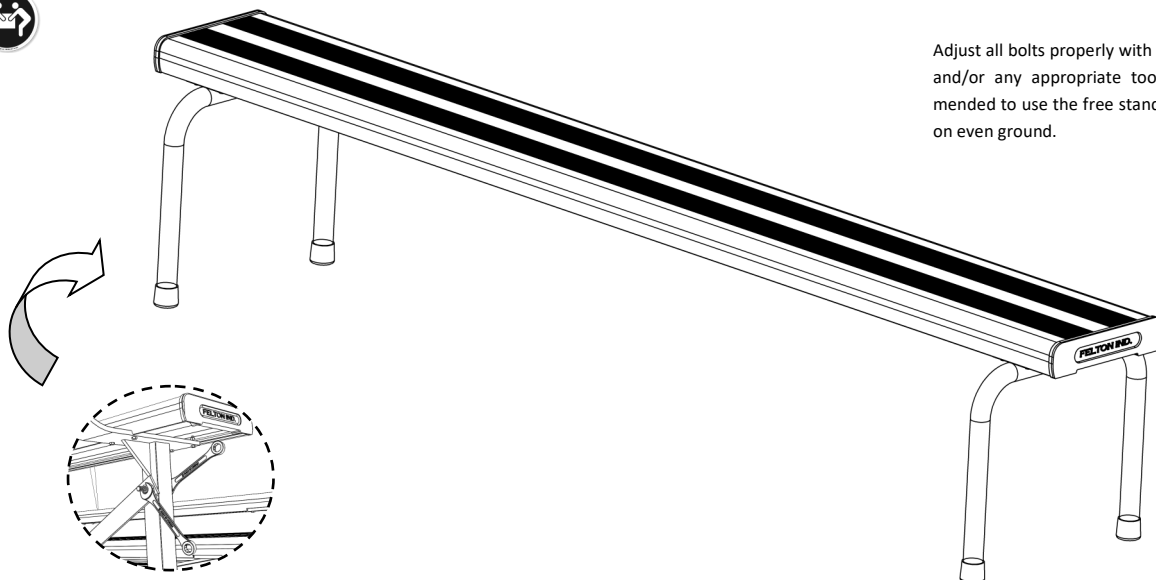

Place the seat plank (FSS2) up side down on a flat surface and attached it to the free standing frames (FSS1), by using hexagonal head bolts (FSS3) and locknuts (FSS4) — finger tighten.



Adjust all bolts properly with a span, wrench and/or any appropriate tool. It is recommended to use the free standing bench seat on even ground.