

**WARNING: READ THE ASSEMBLING INSTRUCTIONS CAREFULLY BEFORE ASSEMBLING THE DOUBLE PLANK BACK REST SPECTATOR SEATING.**



Make sure to wear protective gloves and foot protection when installing and assembling this product. Unpack the unit and make sure all the components are included before proceeding. This activity requires two or more people as lifting is involved. Please ensure bolts are only finger tightened during the assembling process for flexibility in lining up components. Securely tighten the bolts before anchoring the product to the ground.



**DOUBLE PLANK BACK REST SPECTATOR SEATING**

PRODUCT CODE (2TGS1)

PART No.	PART NAME	QTY
2TGS1	MAIN FRAME	2
2TGS2	BACK REST FLAT BAR	1
2TGS3	2000 mm.-BACK REST PLANK	1
2TGS4	2000mm.-SEATING PLANK	4
2TGS5	M10x35mm.-CUP HEAD BOLT	2
2TGS6	M6x25 mm. HEX. HEAD BOLT	36
2TGS7	M6 LOCKNUT	36
2TGS8	M10 LOCKNUT	2
2TGS9	M10 PLAIN WASHER	2

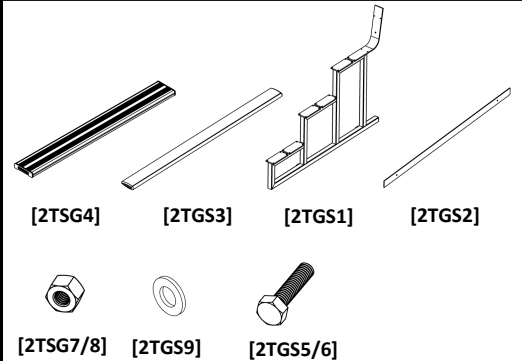

1

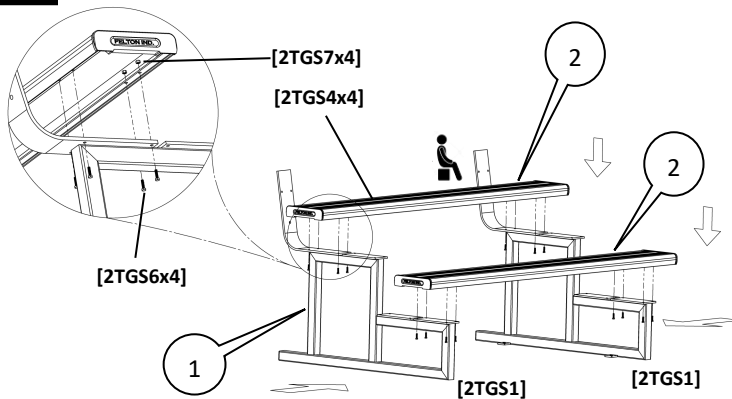

A. Place two frames [2TGS1] with lugs facing inwards and secure them to the back and front seating planks [2TGS4], by using hexagonal head bolts [2TGS6] and locknuts [2TGS7] -finger tighten.

2

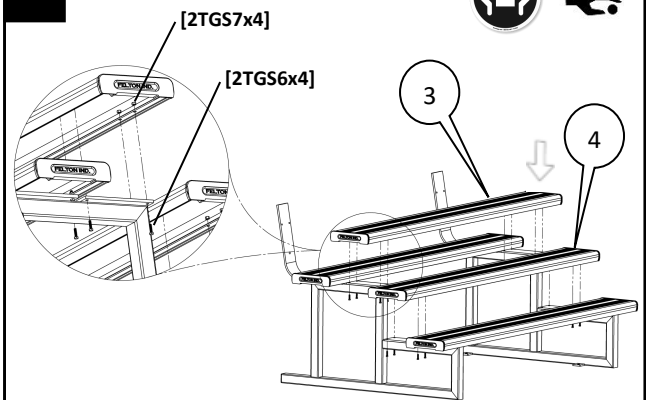

Install the rest of seating planks [2TGS4] as shown above. Make sure to fix the seating planks with hexagonal head bolts [2TGS6] and locknuts [2TGS7] -finger tighten.

3

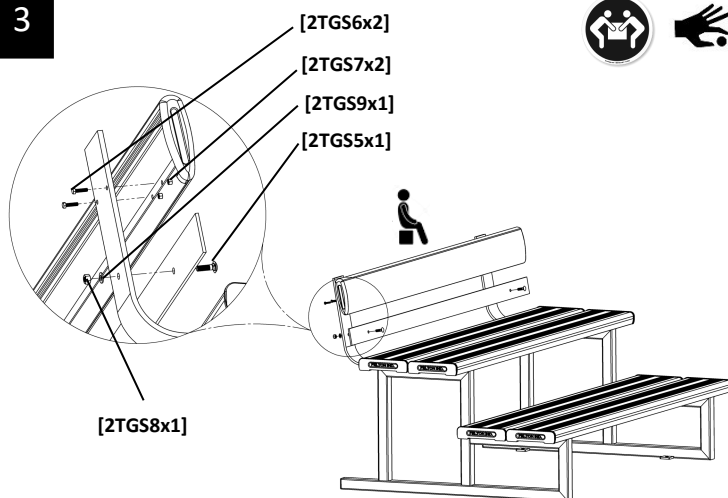

A. Have the back rest flat bar [2TGS2] in place and secure it to the main frames plates [2TGS1], by using cup head carriage bolts [2TGS5], locknuts [2TGS8] and plain washers [2TGS9] - Finger tighten.  
B. Install the back rest plank [2TGS3] onto the top frames [2TGS1] and secure them with hexagonal head bolts [2TGS6] and lock nuts [2TGS7] - finger tighten.

4

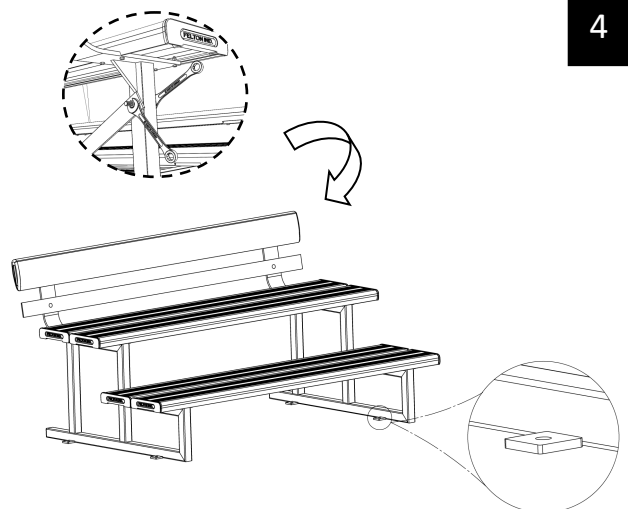

A. Tighten the whole structure with spanners and appropriate tools.  
B. Attach the whole unit to the ground, with dyna-bolts on each frame lug.