

WARNING: READ THE ASSEMBLING INSTRUCTIONS CAREFULLY BEFORE ASSEMBLING THE QUAD PLANK SEATING.

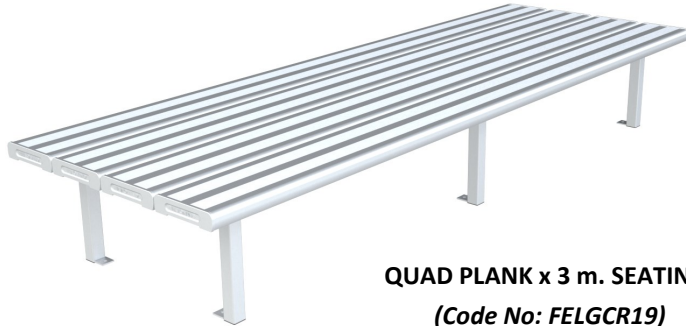

Make sure to wear protective gloves and foot protection when installing and assembling this product. Unpack the unit and make sure all the components are included before proceeding. This activity requires two or more people as lifting is involved. Please ensure bolts are only finger-tightened during the assembling process for flexibility in lining up components. Securely tighten the bolts before anchoring the product to the ground.



QUAD PLANK x 3 m. SEATING.
(Code No: FELGCR19)

PART No.	PART NAME	QTY
GDR1	ALUMINIUM FRAME	3
GDR2	3000- mm. ALUMINIUM SEATING PLANK	4
GDR3	M6 X25 mm. HEXAGONAL HEAD BOLT	48
GDR4	M6 LOCKNUT	48



[GDR1]



[GDR2]



[GDR3]



[GDR4]

Thank you for purchasing our high quality products. The Quad Plank Seating has been well manufactured with certified materials, to achieve high reliability and minimum maintenance. It is our commitment to provide you cost-effective solutions for outdoor applications.

1

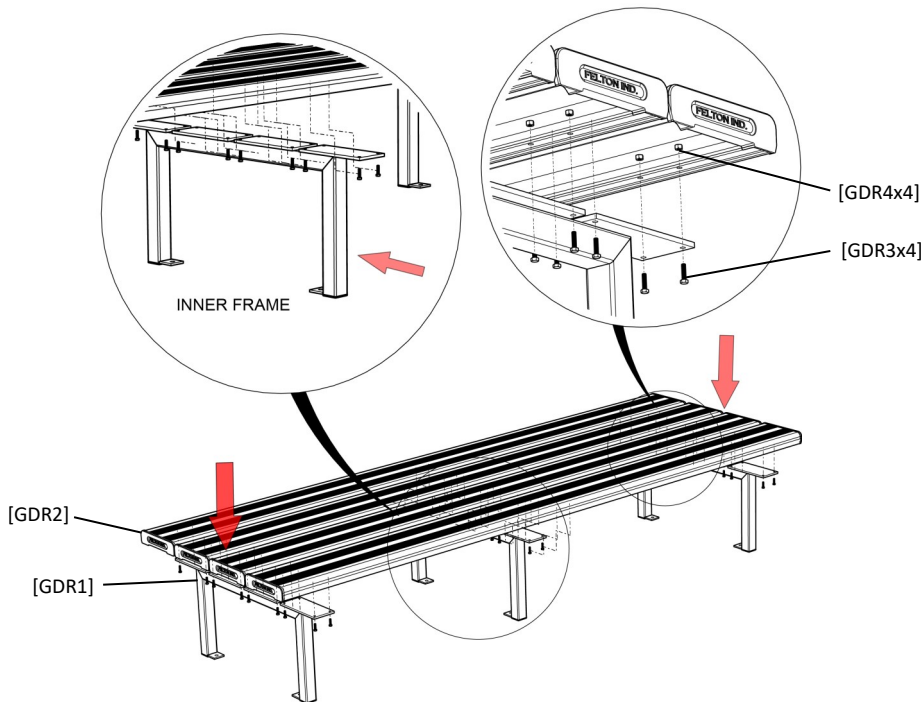

- A. Have the Aluminium frames [GDR1] up with bolt down lugs facing ground.
- B. Place the seating planks [GDR2] onto top frames [GDR1] and secure them with hex. head bolts [GDR3] and locknuts [GDR4] - finger tighten.
- C. Have the inner frame [GDR1] in place and attach it to the seating planks [GDR2] with hex. head bolts [GDR3] and locknuts [GDR4] - finger tighten.

2

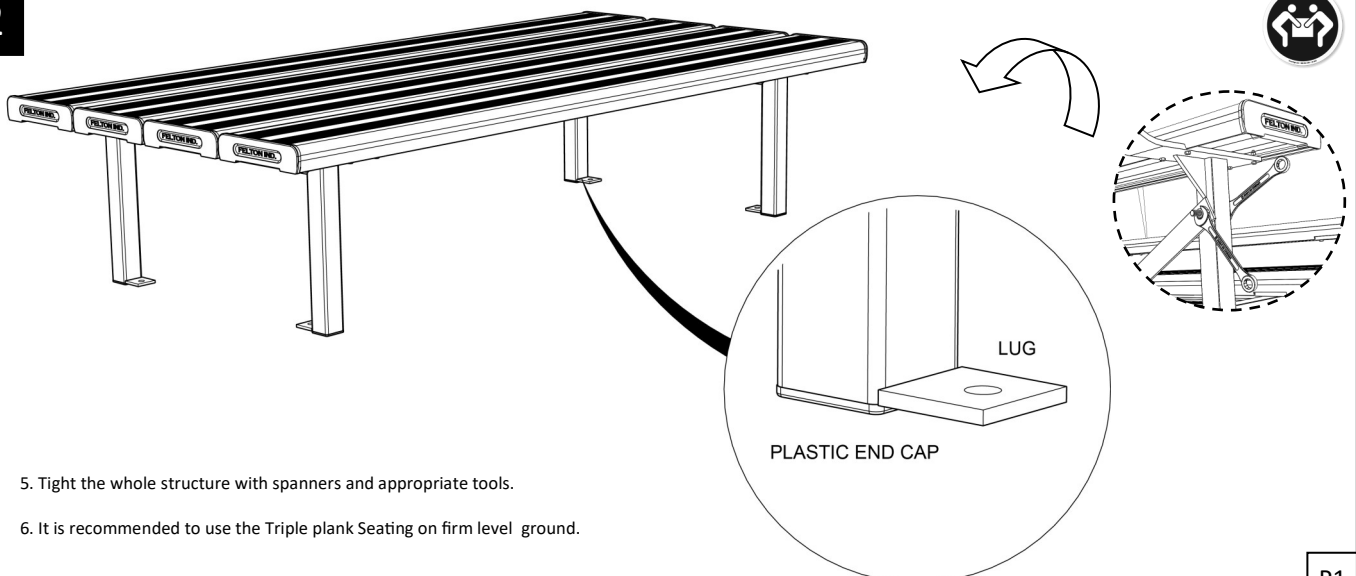

5. Tight the whole structure with spanners and appropriate tools.
6. It is recommended to use the Triple plank Seating on firm level ground.