

WARNING: READ THE ASSEMBLING INSTRUCTIONS CAREFULLY BEFORE ASSEMBLING THE TRIPLE PLANK SEATING.

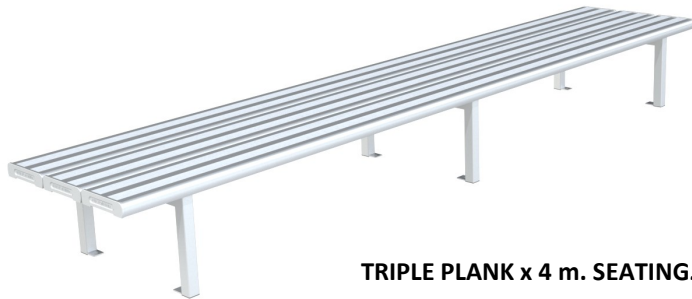

Make sure to wear protective gloves and foot protection when installing and assembling this product. Unpack the unit and make sure all the components are included before proceeding. This activity requires two or more people as lifting is involved. Please ensure bolts are only finger-tightened during the assembling process for flexibility in lining up components. Securely tighten the bolts before anchoring the product to the ground.



TRIPLE PLANK x 4 m. SEATING.
(Code No: FELGCR17)

| PART No. | PART NAME | QTY |
|----------|-----------------------------------|-----|
| GDR1 | ALUMINIUM FRAME | 3 |
| GDR2 | 3000- mm. ALUMINIUM SEATING PLANK | 3 |
| GDR3 | M6 X25 mm. HEXAGONAL HEAD BOLT | 36 |
| GDR4 | M6 LOCKNUT | 36 |



[GDR1]



[GDR2]



[GDR3]



[GDR4]

Thank you for purchasing our high quality products. The Triple Plank Seating has been well manufactured with certified materials, to achieve high reliability and minimum maintenance. It is our commitment to provide you cost-effective solutions for outdoor applications.

1

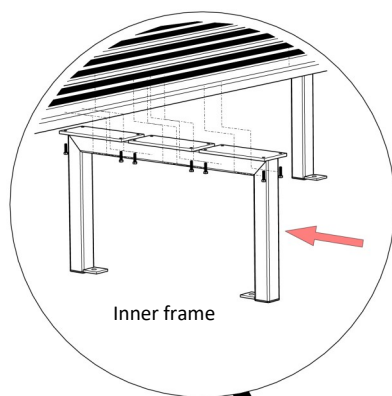

Inner frame

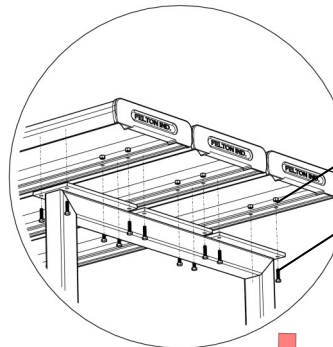

[GDR4x4]

[GDR3x4]



[GDR2]

[GDR1]

A. Have the Aluminium frames [GDR1] up with bolt down lugs facing ground.

B. Place the seating planks [GDR2] onto top frames [GDR1] and secure them with hex. head bolts [GDR3] and locknuts [GDR4] - finger tighten.

C. Have the inner frame [GDR1] in place and attach it the seating planks [GDR2] with hex. head bolts [GDR3] and locknuts [GDR4] - finger tighten.

2

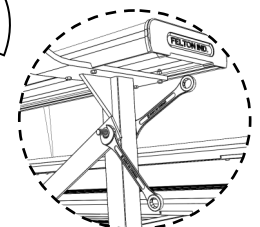
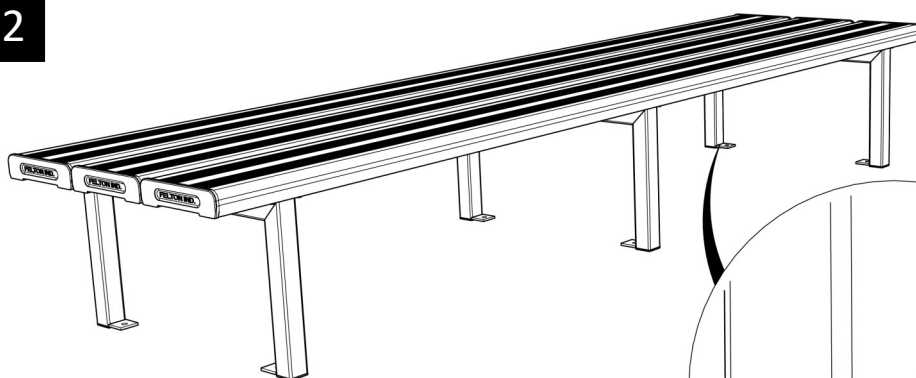

LUG

PLASTIC END CAP

5. Tight the whole structure with spanners and appropriate tools.

6. It is recommended to use the Triple plank Seating on firm level ground.