

WARNING: READ THE ASSEMBLY INSTRUCTIONS CAREFULLY BEFORE ASSEMBLING THE BOLT DOWN PARK SETTING.



Make sure to wear protective gloves and foot protection when installing and assembling this product. Unpack the unit and make sure all the components are included before proceeding. This activity requires two or more people as lifting is involved. Please ensure bolts are only finger-tightened during the assembling process for flexibility in lining up components. Securely tighten all bolts before fixing the product to the ground.



**BOLT DOWN PARK SETTING
(CODE No. FELAGPS)**

ITEM	DESCRIPTION	QTY
BGP1	TABLE FRAME	2
BGP2	SEAT FRAME	4
BGP3	SEAT / TABLE PLANK—1800 mm.	2/3
BGP4	M6 x 25mm. HEXAGONAL HEAD BOLT	40
BGP5	M6 LOCKNUT	40



1

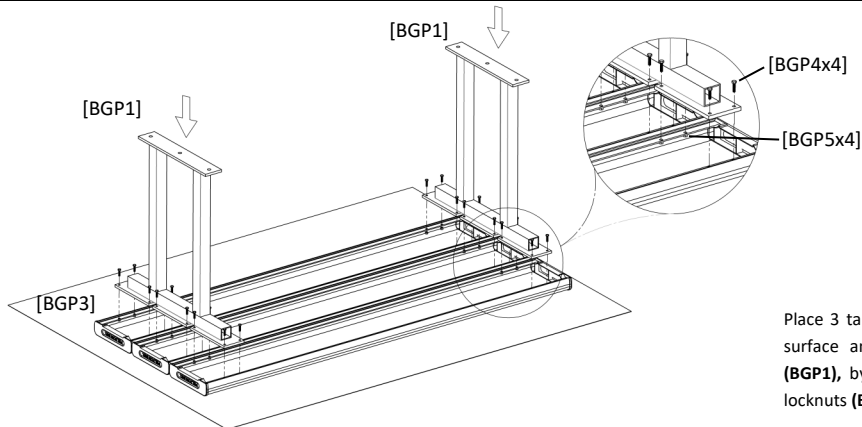

Place 3 table planks (**BGP3**) upside down on a flat surface and attached them to the table frames (**BGP1**), by using hexagonal head bolts (**BGP4**) and locknuts (**BGP5**) - finger tighten.

2

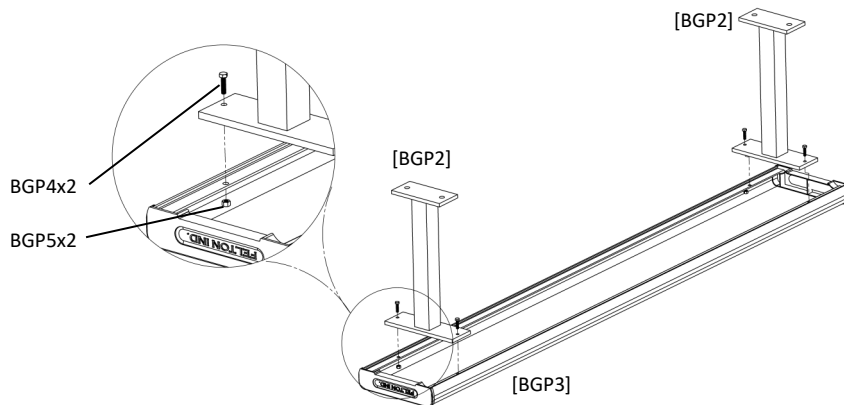

Place a seat plank (**BGP3**) upside down on a flat surface and attached them to the seat frames (**BGP2**), by using hexagonal head bolts (**BGP4**) and locknuts (**BGP5**). - finger tighten.

3

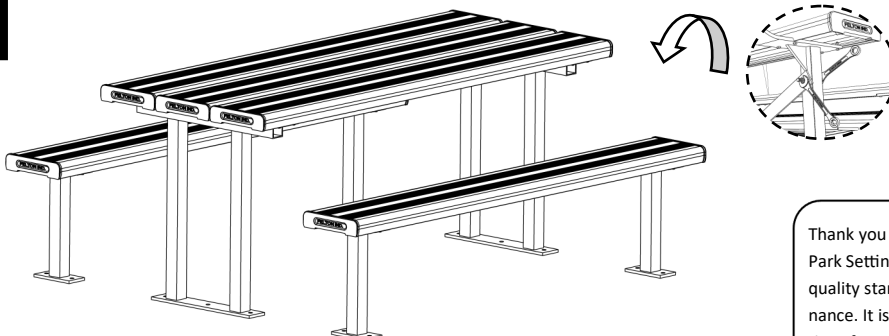

Adjust all fasteners properly, with span, wrench and/or any appropriate tool.

Fix the bolt down park setting to the ground, by installing dyna bolts on the frame lugs.

Thank you for purchasing our high quality products. The Bolt Down Park Setting has been manufactured with certified materials and quality standards, to achieve high reliability and minimum maintenance. It is our commitment to provide you cost-effective solutions for outdoor applications.