

WARNING: READ THE ASSEMBLY INSTRUCTIONS CAREFULLY BEFORE ASSEMBLING THE INTERACTIVE WHEELCHAIR SETTING.

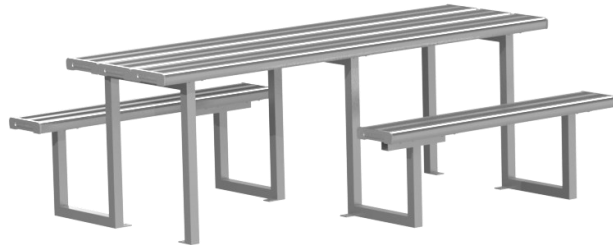

Make sure to wear protective gloves and foot protection when installing and assembling this product. Unpack the unit and make sure all the components are included before proceeding. This activity requires two or more people as lifting is involved. Please ensure all bolts are only finger-tightened during the assembling process for flexibility in lining up components. Securely tighten the bolts before anchoring the product to the ground.



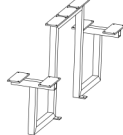

**INTERACTIVE WHEELCHAIR SETTING
(CODE No. FELIWS)**

| ITEM PART | DESCRIPTION | QTY |
|-----------|--------------------------------|-----|
| FELIWS1 | CENTRAL SEAT FRAME | 1 |
| FELIWS2 | SIDE SEAT FRAME | 2 |
| FELIWS3 | 1440 mm.—ALUMINIUM SEAT PLANK | 2 |
| FELIWS4 | 2400 mm.—ALUMINIUM TABLE PLANK | 3 |
| FELIWS5 | M6x25mm. HEXAGONAL HEAD BOLT | 60 |
| FELIWS6 | M6 LOCKNUT | 60 |

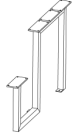
FELIWS 1



FELIWS 2

FELIWS3/4

FELIWS 5

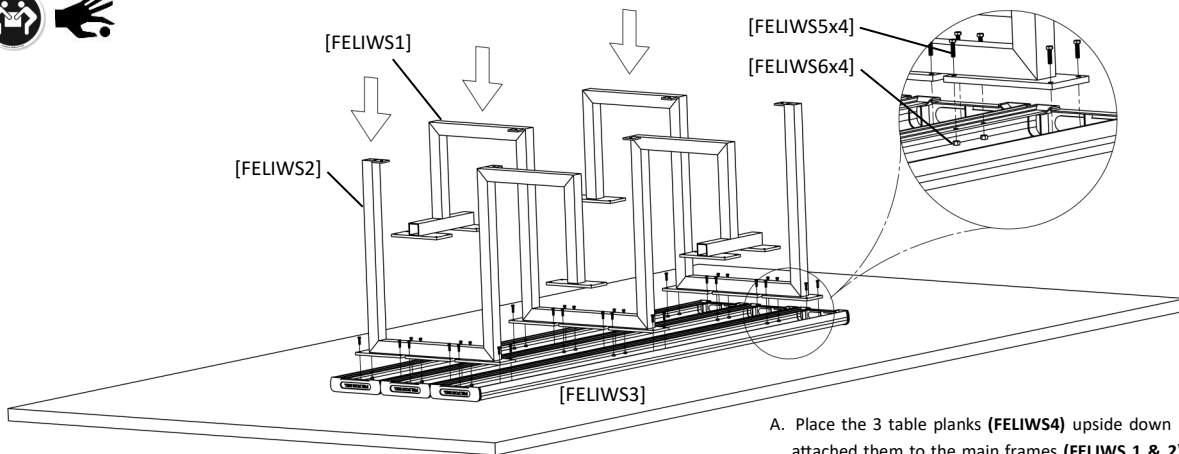

FELIWS6

Thank you for purchasing our high quality products. The Interactive Wheel Chair Setting has been manufactured with certified materials, to achieve high reliability and minimum maintenance. It is our commitment to provide you cost effective solutions for outdoor applications.

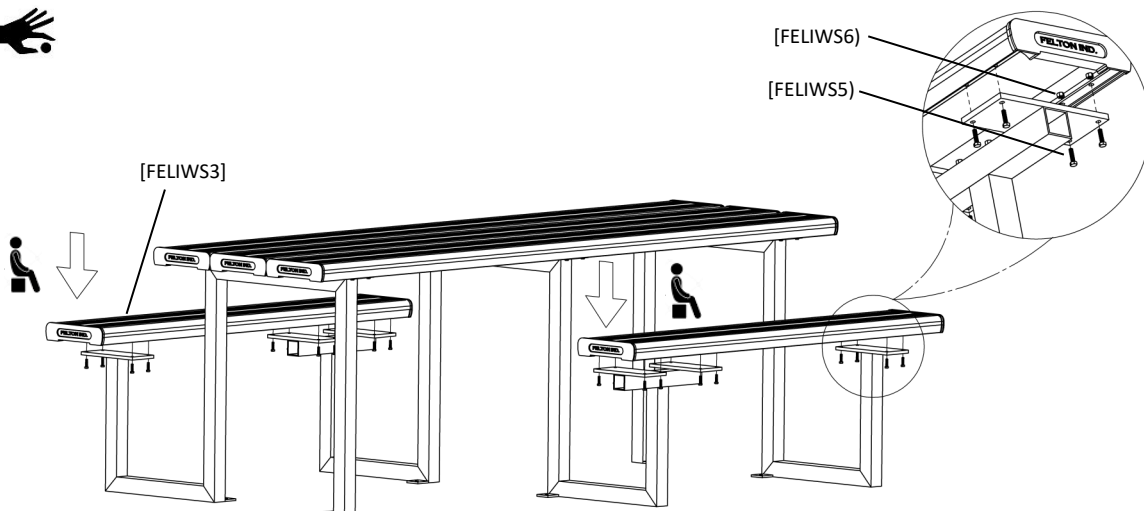

A. Place the 3 table planks (**FELIWS4**) upside down on a flat surface and attached them to the main frames (**FELIWS 1 & 2**), by using hexagonal head bolts (**FELIWS 5**) and locknuts (**FELIWS 6**) - finger tighten.

1



A. Turn the whole assembly up and attach the seat planks (**FELIWS3**) to seat frames (**FELIWS1/2**), by using hexagonal head bolts (**FELIWS5**) and locknuts (**FELIWS6**) as indicated in the illustration above - finger tighten.

2

WARNING: READ THE ASSEMBLY INSTRUCTIONS CAREFULLY BEFORE ASSEMBLING THE INTERACTIVE WHEELCHAIR SETTING.



Make sure to wear protective gloves and foot protection when installing and assembling this product. Unpack the unit and make sure all the components are included before proceeding. This activity requires two or more people as lifting is involved. Please ensure all bolts are only finger-tightened during the assembling process for flexibility in lining up components. Securely tighten the bolts before anchoring the product to the ground.



3

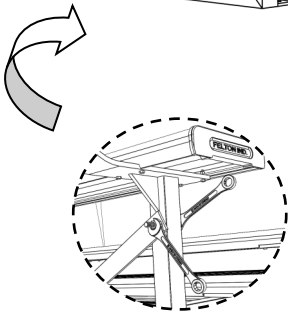
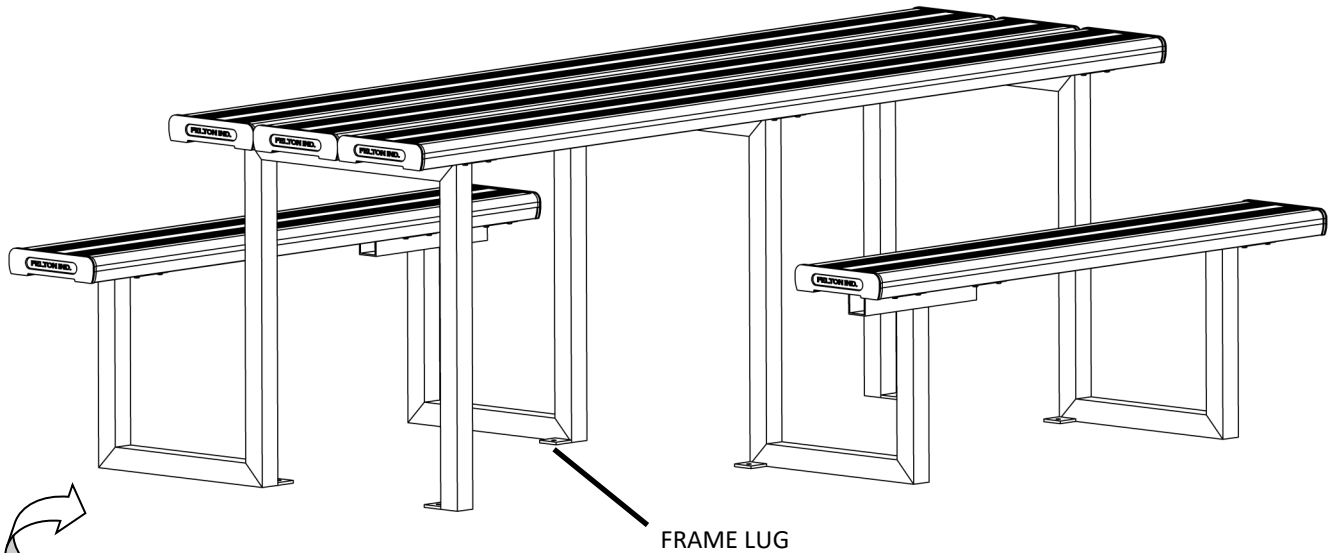

- A. Tighten all bolts with a spanner, wrenches and/or an appropriate tool to secure the whole unit.
- B. Anchor the Interactive Wheelchair setting to the ground, by using dyna bolts on each frame lug.