

WARNING: READ THE ASSEMBLY INSTRUCTIONS CAREFULLY BEFORE ASSEMBLING THE STANDARD WHEELCHAIR SETTING.

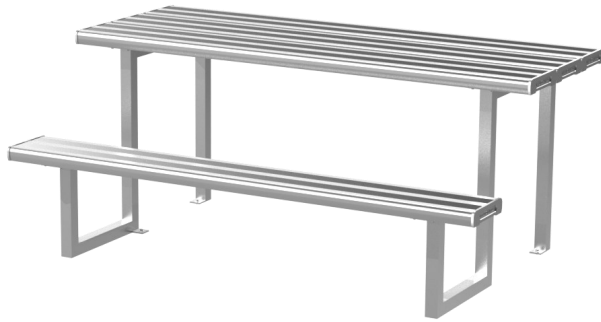

Make sure to wear protective gloves and foot protection when installing and assembling this product. Unpack the unit and make sure all the components are included before proceeding. This activity requires two or more people as lifting is involved. Please ensure all bolts are only finger-tightened during the assembling process for flexibility in lining up components. Securely tighten the bolts before anchoring the product to the ground.



**STANDARD WHEELCHAIR SETTING
(CODE No. FELSW5)**

ITEM PART	DESCRIPTION	QTY
FELSW51	MAIN FRAME	2
FELSW52	2000 mm.—SEAT/TABLE PLANK	2/2
FELSW53	M6x25mm. HEXAGONAL HEAD BOLT	32
FELSW54	M6 LOCKNUT	32

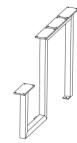

FELSW51



FELSW52



FELSW53



FELSW54

Thank you for purchasing our high quality products. The Standard Wheelchair Setting has been manufactured with certified materials, to achieve high reliability and minimum maintenance. It is our commitment to provide you cost effective solutions for outdoor applications.

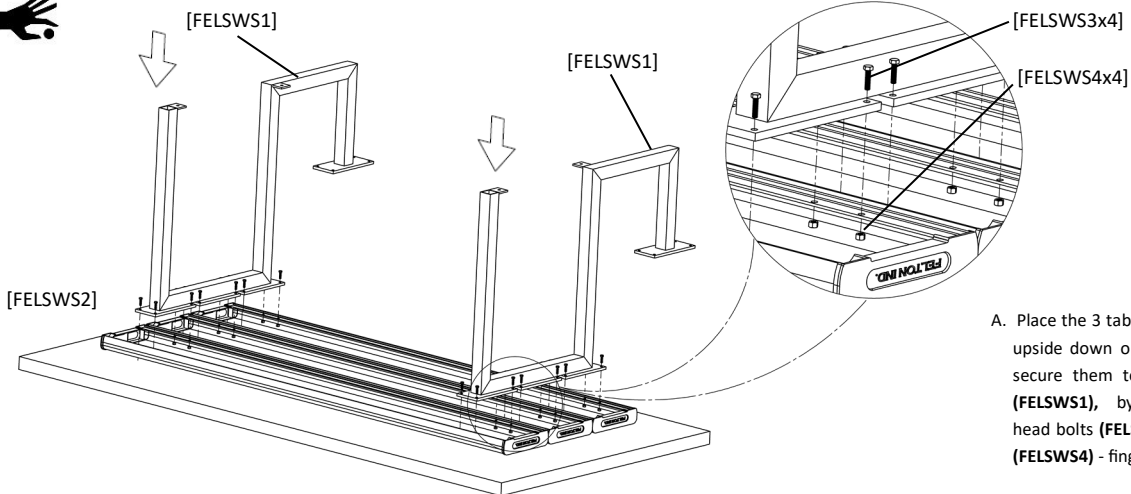

1

A. Place the 3 table planks (FELSW52) upside down on a flat surface and secure them to the main frames (FELSW51), by using hexagonal head bolts (FELSW53) and locknuts (FELSW54) - finger tighten.

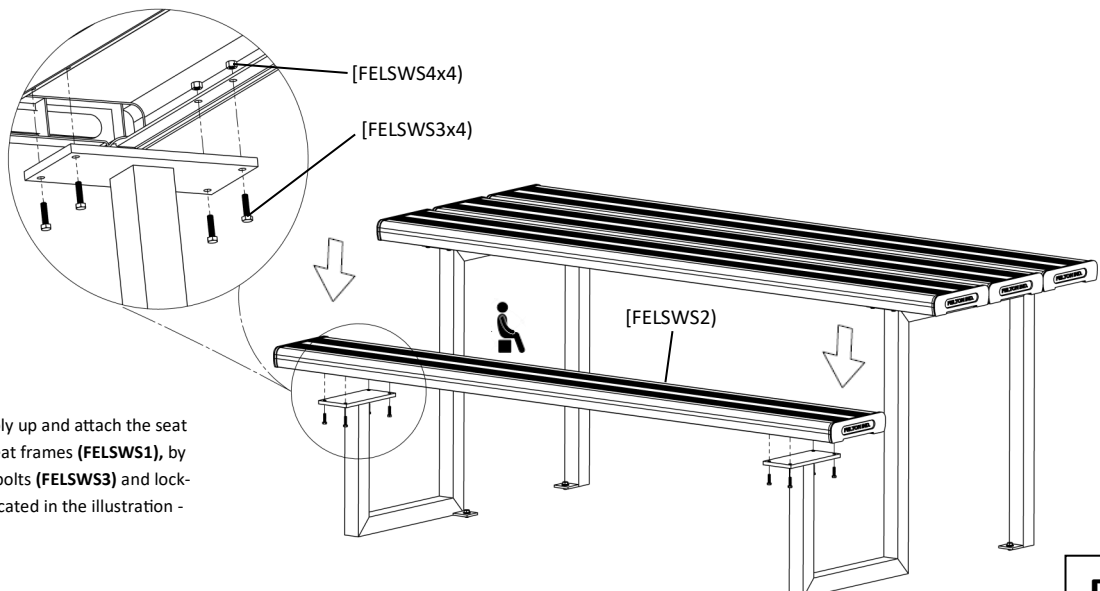

2

A. Turn the whole assembly up and attach the seat planks (FELSW52) to seat frames (FELSW51), by using hexagonal head bolts (FELSW53) and locknuts (FELSW54) as indicated in the illustration - finger tighten.

P1

WARNING: READ THE ASSEMBLY INSTRUCTIONS CAREFULLY BEFORE ASSEMBLING THE STANDARD WHEELCHAIR SETTING.



Make sure to wear protective gloves and foot protection when installing and assembling this product. Unpack the unit and make sure all the components are included before proceeding. This activity requires two or more people as lifting is involved. Please ensure all bolts are only finger-tightened during the assembling process for flexibility in lining up components. Securely tighten the bolts before anchoring the product to the ground.



3

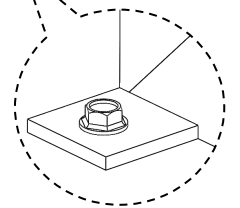
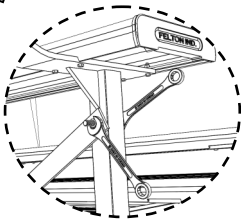
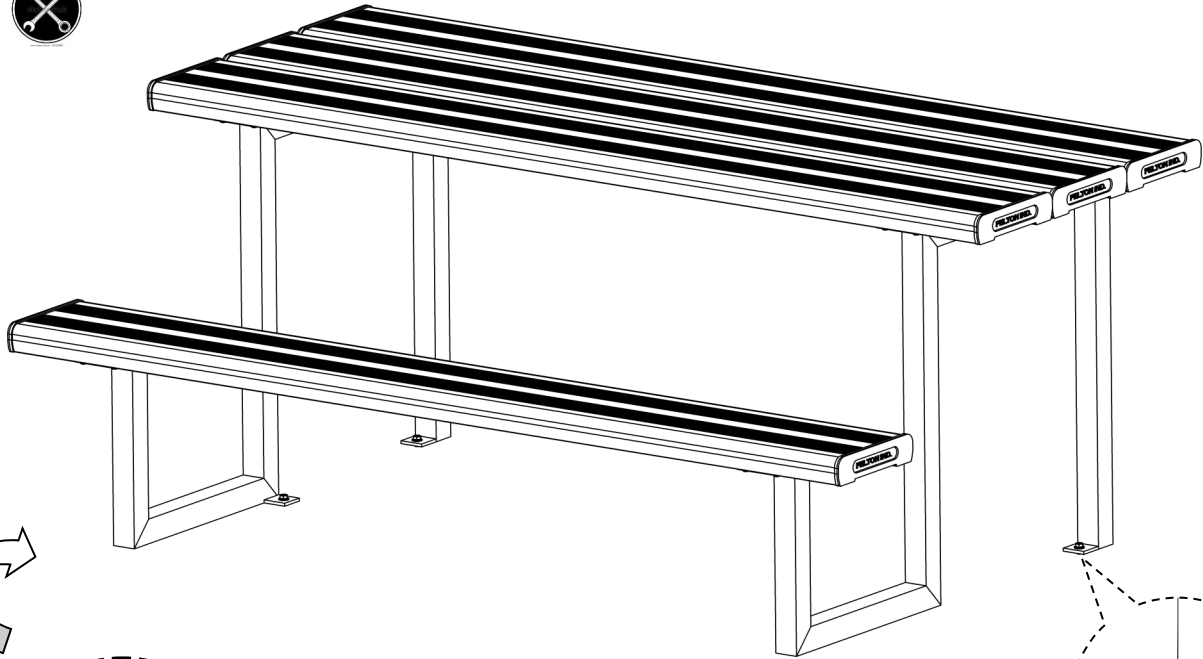

- A. Tighten all bolts with a spanner, wrench and/or an appropriate tool to secure the whole unit.
- B. Fix the Standard Wheelchair setting to the ground, by using dyna bolts on each frame lug.