

# ASSEMBLY INSTRUCTION

*Thank You*

FOR CHOOSING FELTON INDUSTRIES

INTERACTIVE WHEELCHAIR SETTING  
[Code No: FELIWS]

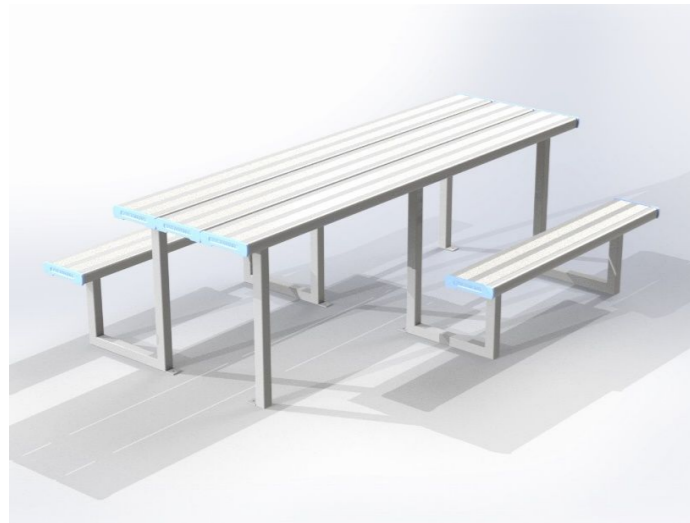

"This product has been manufactured in Australia to the highest quality standard, guaranteeing proven quality, durability and low maintenance"



1800 22 00 55

1800 05 91 58

sales@felton.net.au

www.felton.net.au



Felton Industries Pty Ltd | ABN: 17 130 687 240



WARNING: This assembly required two or more people as lifting is involved. **Please ensure bolts and nuts are only finger-tightened throughout assembly for flexibility in lining up components.** Bolt and nuts should be securely tightened in place when instructed to do so. Please check all components are included before proceeding with the assembly

ITEM	DESCRIPTION	Qty
1	FELIWS_CENTRAL FRAME	1
2	FELIWS_SIDE FRAME	2
3	FELIWS_TABLE PLANK L2400	3
4	FELIWS_SEAT PLANK L1440	2
5	AS-NZS 2465 Bolt - 1/4" x 1"	52
6	AS-NZS NYLON Nut - 1/4"	52

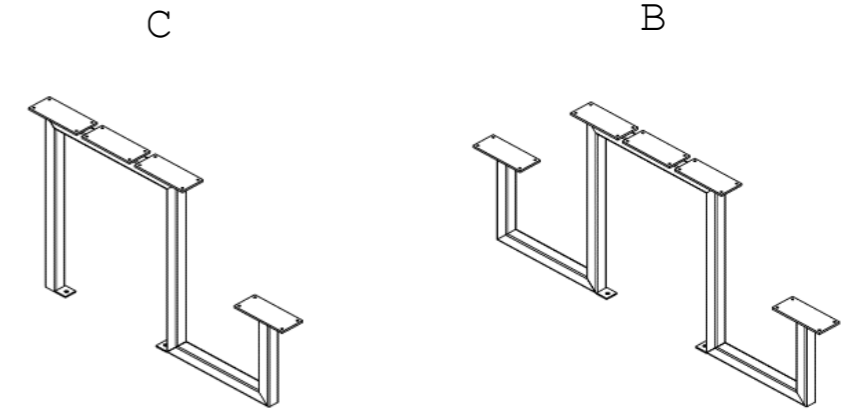
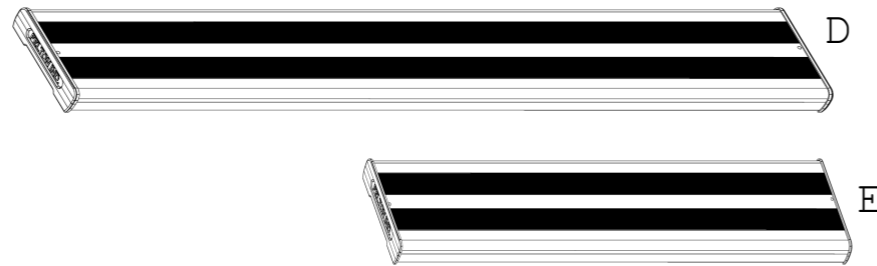
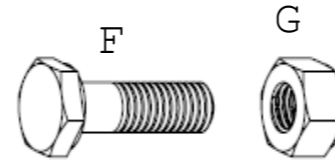

**1**

Place three table planks D upside down and close together on the ground as illustrated.

**2**

Attach central base frame B and two side frames C to three planks D in step 1 by using bolts F and nuts G as illustrated. **Note that all fixing lugs on base frames B & C face inwards.**

**3**

Turn the assembly in step 2 up, then attach two seat planks E onto fixing plates by using bolts F and nuts G as illustrated.

**4**

Tighten all hexagonal head bolts with spanners and appropriate tools. Then attach the whole assembly to the ground by using M12 dyna-bolts preferably, on each frame lug.