

ASSEMBLY INSTRUCTION

Thank You

FOR CHOOSING FELTON INDUSTRIES

**2 TIER 2mtr DOUBLE PLANK WITH
BACKREST SPECTATOR SEATING**
[Code No: 2TGS1]



WARNING: This assembly required two or more people as lifting is involved. **Please ensure bolts and nuts are only finger-tightened throughout assembly for flexibility in lining up components.** Bolt and nuts should be securely tightened in place when instructed to do so. Please check all components are included before proceeding with the assembly

ITEM	DESCRIPTION	Qty
1	2 TIER BACKREST BASE FRAME	2
2	CUT-OUT SEAT PLANK L2000	1
3	TIER PLANK L2000	3
4	BACKREST PLANK L2000	1
5	AL FLAT BAR 80x6xL2000	1
6	AS-NZS 2465 Bolt - 1/4" x 1"	36
7	AS-NZS NYLON Nut - 1/4"	36
8	AS 1112 Bolt - 3/8" x 1"	2
9	AS 1112 Nut - 3/8"	2

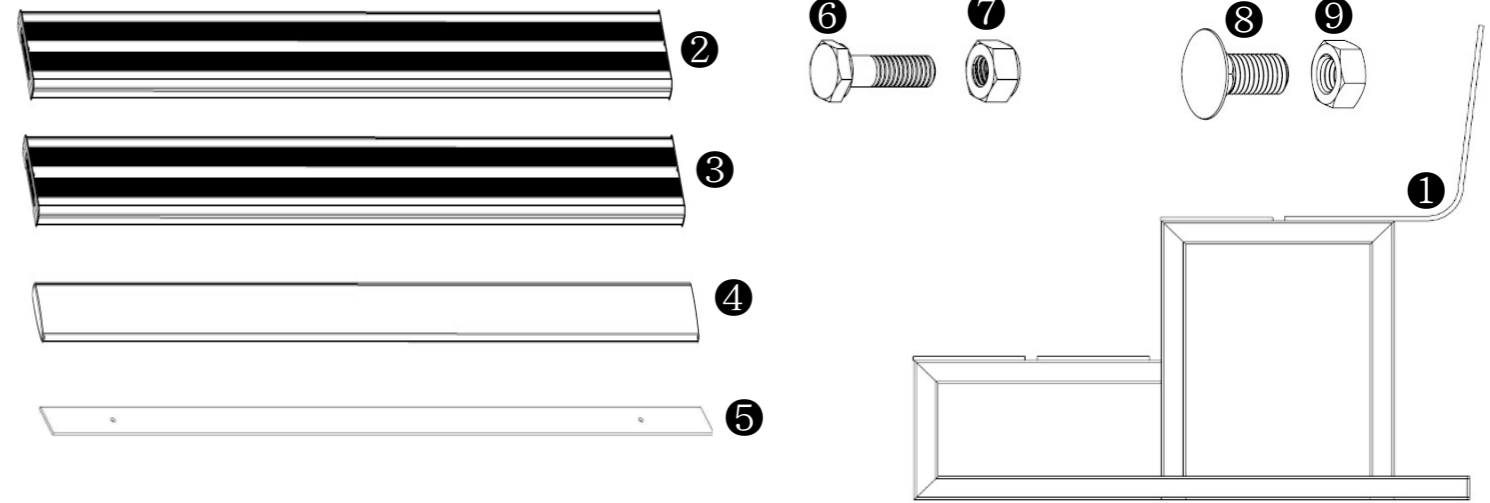

1

Attach plank **2** (with notch cut beneath) to two base frames **1** by using bolts **6** and nuts **7**. **Note that all fixing lugs on base frames 1 face inwards.**

2

Attach plank **3** to the assembly in step 1 by using bolts **6** and nuts **7** as illustrated.

3

Repeat step 2 with two remaining planks **3** at lower position on base frame **1**.

4

Install the backrest plank **4** onto frame fixing plates as illustrated. Fasten the backrest planks **4** with hexagonal bolts **6** and nuts **7**. Ensure the fixing plates are installed in the right place on backrest plank.

5

Attach the long flat bar **5** to fixing plates by using bolts **8** and nuts **9** as illustrated.

6

Tighten all hexagonal head bolts with spanners and appropriate tools. Then completely tighten the dynabolts to attach the whole assembly firmly to the ground.

"This product has been manufactured in Australia to the highest quality standard, guaranteeing proven quality, durability and low maintenance"



1800 22 00 55

1800 05 91 58

sales@felton.net.au

www.felton.net.au



Felton Industries Pty Ltd | ABN: 17 130 687 240