

ASSEMBLY INSTRUCTION

Thank You

FOR CHOOSING FELTON INDUSTRIES

**2 TIER 4mtr DOUBLE PLANK WITH
BACKREST SPECTATOR SEATING**
[Code No: 2TGS3]



"This product has been
manufactured in Australia to the
highest quality standard,
guaranteeing proven quality,
durability and low maintenance"



1800 22 00 55

1800 05 91 58

sales@felton.net.au

www.felton.net.au



Felton Industries Pty Ltd | ABN: 17 130 687 240



WARNING: This assembly required two or more people as lifting is involved. **Please ensure bolts and nuts are only finger-tightened throughout assembly for flexibility in lining up components.** Bolt and nuts should be securely tightened in place when instructed to do so. Please check all components are included before proceeding with the assembly

ITEM	DESCRIPTION	Qty
1	2 TIER BACKREST BASE FRAME	4
2	CUT-OUT SEAT PLANK L4000	1
3	TIER PLANK L4000	3
4	BACKREST PLANK L4000	1
5	AL FLAT BAR 80x6xL4000	1
6	AS-NZS 2465 Bolt - 1/4" x 1"	72
7	AS-NZS NYLON Nut - 1/4"	72
8	AS 1112 Bolt - 3/8" x 1"	4
9	AS 1112 Nut - 3/8"	4

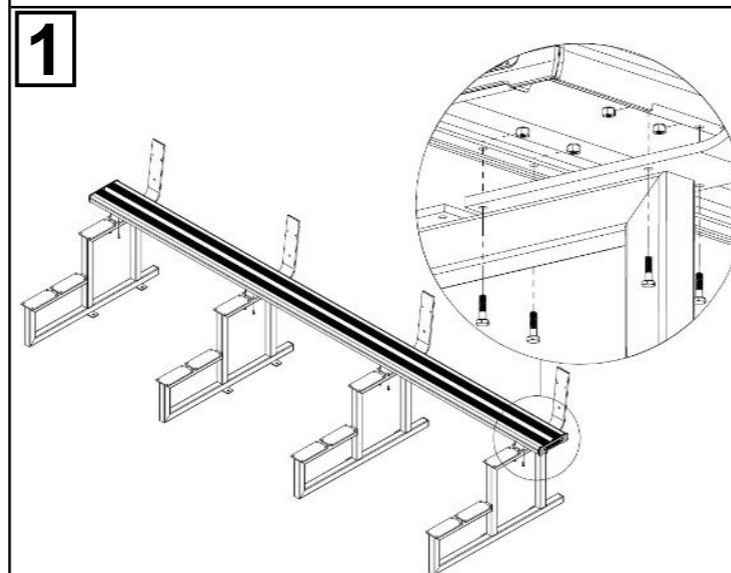
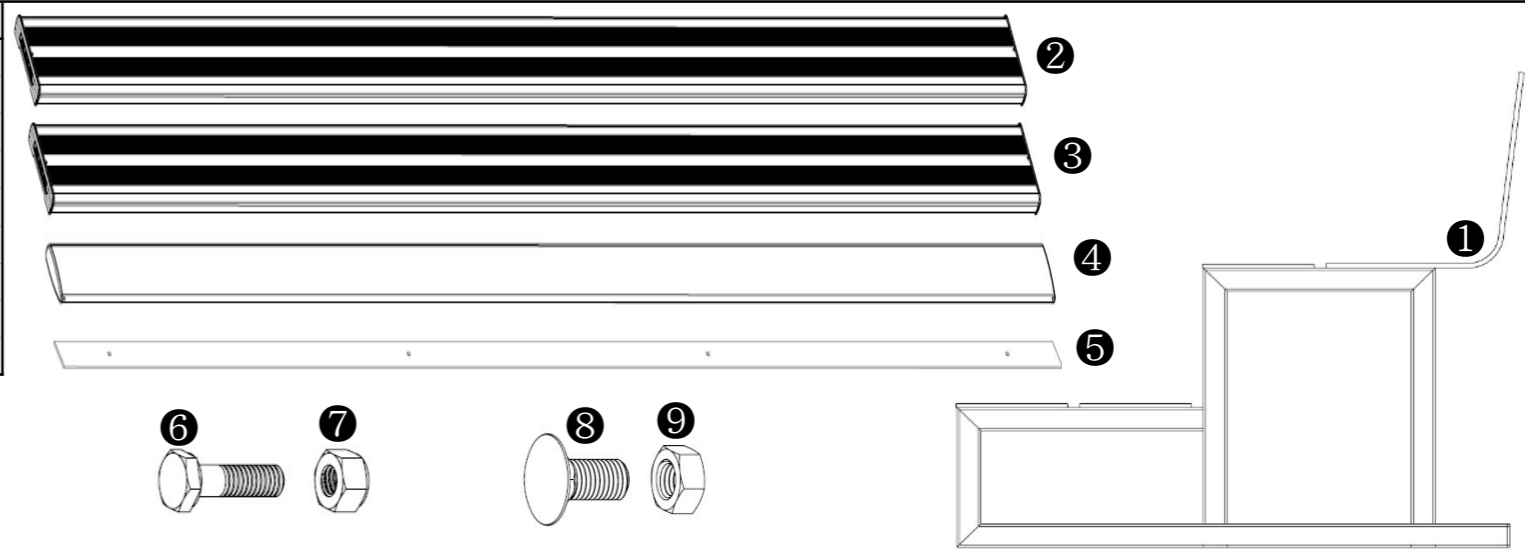

Attach plank **2** (with notch cut beneath) to four base frames **1** by using bolts **6** and nuts **7**. **Note that all fixing lugs on base frames 1 face inwards.**

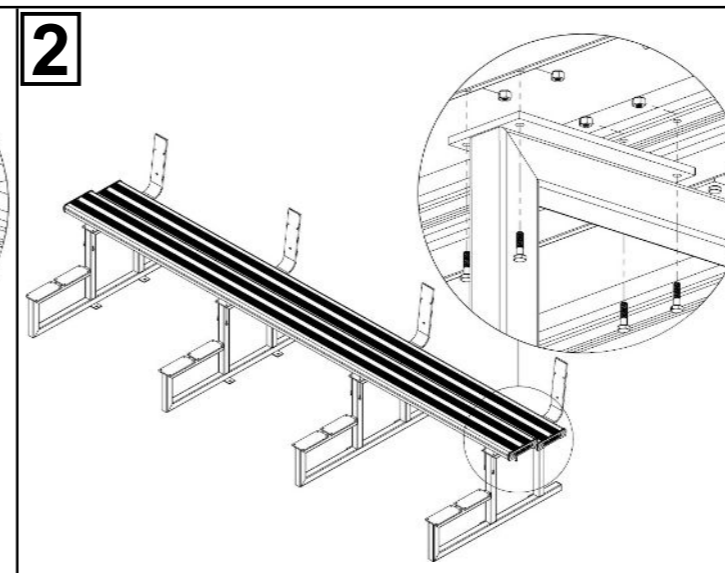

Attach plank **3** to the assembly in step 1 by using bolts **6** and nuts **7** as illustrated.

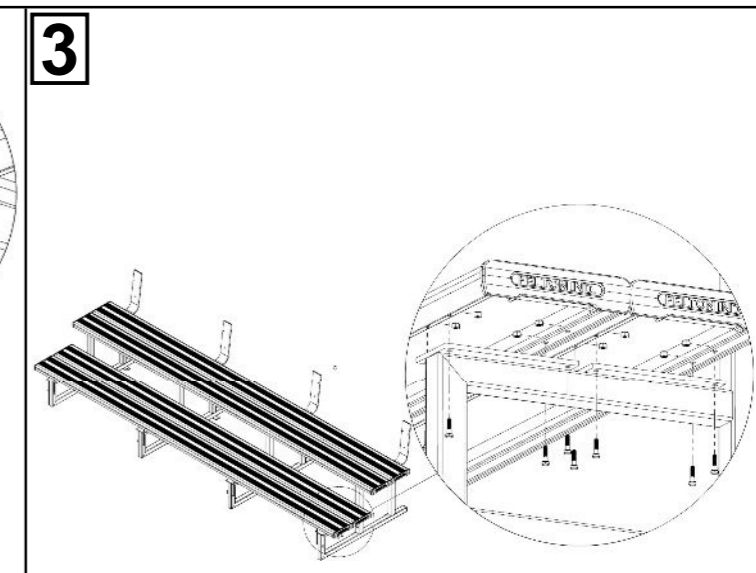

Repeat step 2 with two remaining planks **3** at lower position on base frame **1**.

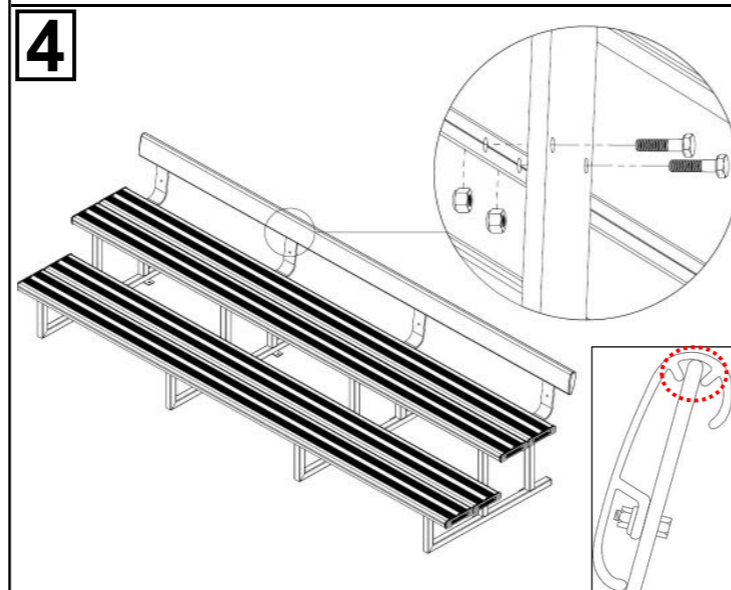

Install the backrest plank **4** onto frame fixing plates as illustrated. Fasten the backrest planks **4** with hexagonal bolts **6** and nuts **7**. Ensure the fixing plates are installed in the right place on backrest plank.

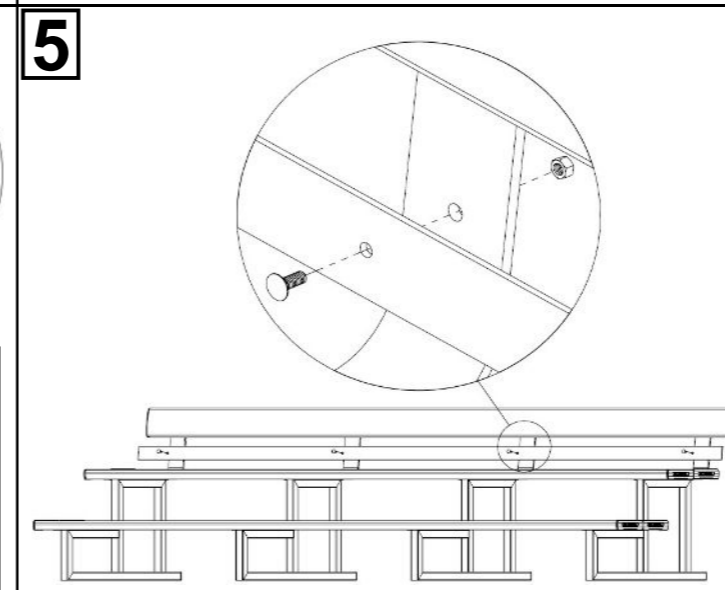

Attach the long flat bar **5** to fixing plates by using bolts **8** and nuts **9** as illustrated.

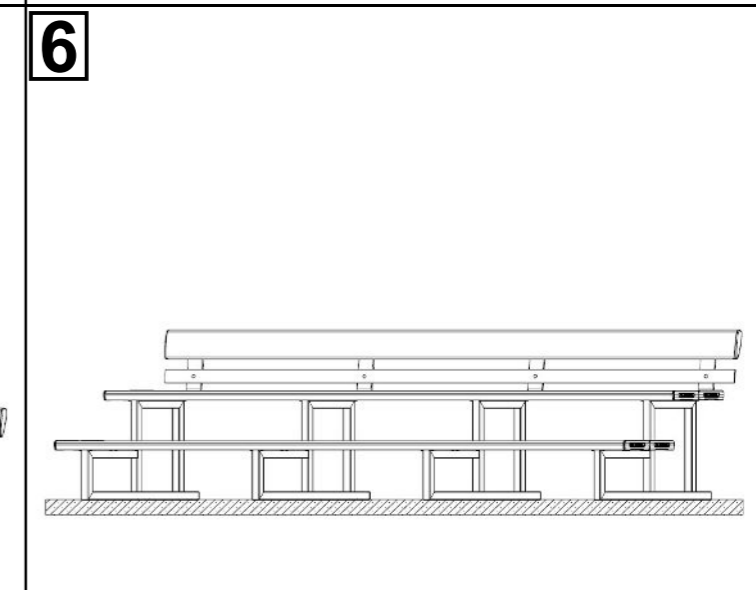

Tighten all hexagonal head bolts with spanners and appropriate tools. Then completely tighten the dynabolts to attach the whole assembly firmly to the ground.