

ASSEMBLY INSTRUCTION

Thank You

FOR CHOOSING FELTON INDUSTRIES

3 TIER BAG RACK 2mtr
[Code No: BR23]



"This product has been manufactured in Australia to the highest quality standard, guaranteeing proven quality, durability and low maintenance"



☎ 1800 22 00 55

📠 1800 05 91 58

✉ sales@felton.net.au

🌐 www.felton.net.au



Felton Industries Pty Ltd | ABN: 130 687 240



WARNING: This assembly required two or more people as lifting is involved. **Please ensure bolts and nuts are only finger-tightened throughout assembly for flexibility in lining up components.** Bolt and nuts should be securely tightened in place when instructed to do so. Please check all components are included before proceeding with the assembly

ITEM	DESCRIPTION	Qty
1	BR_3 TIER MAIN FRAME	2
2	BR_PLANK L2000	6
3	AS-NZS 2465 Bolt - 0.25in x 1in	48
4	AS-NZS NYLON Nut - 0.25in	48

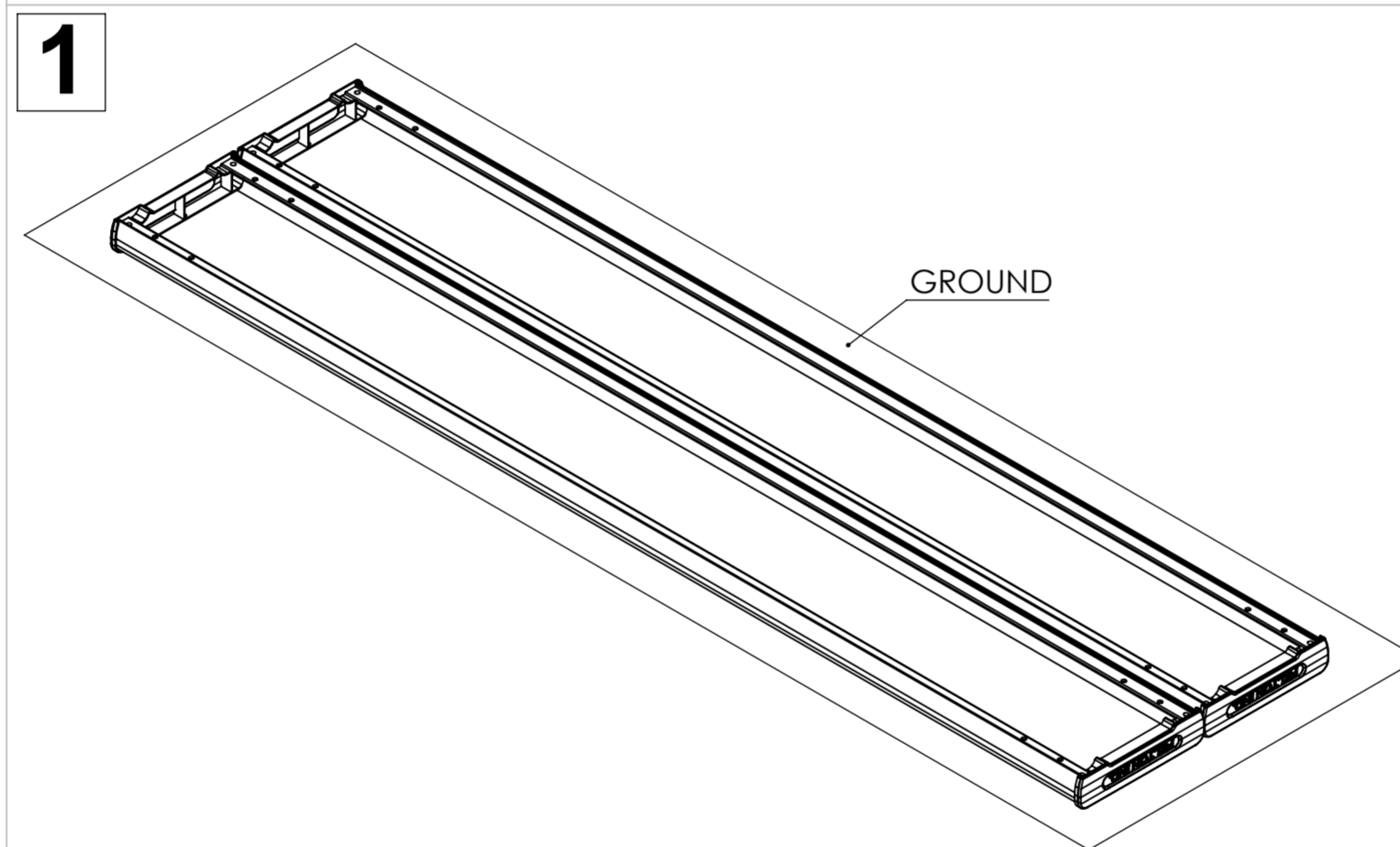
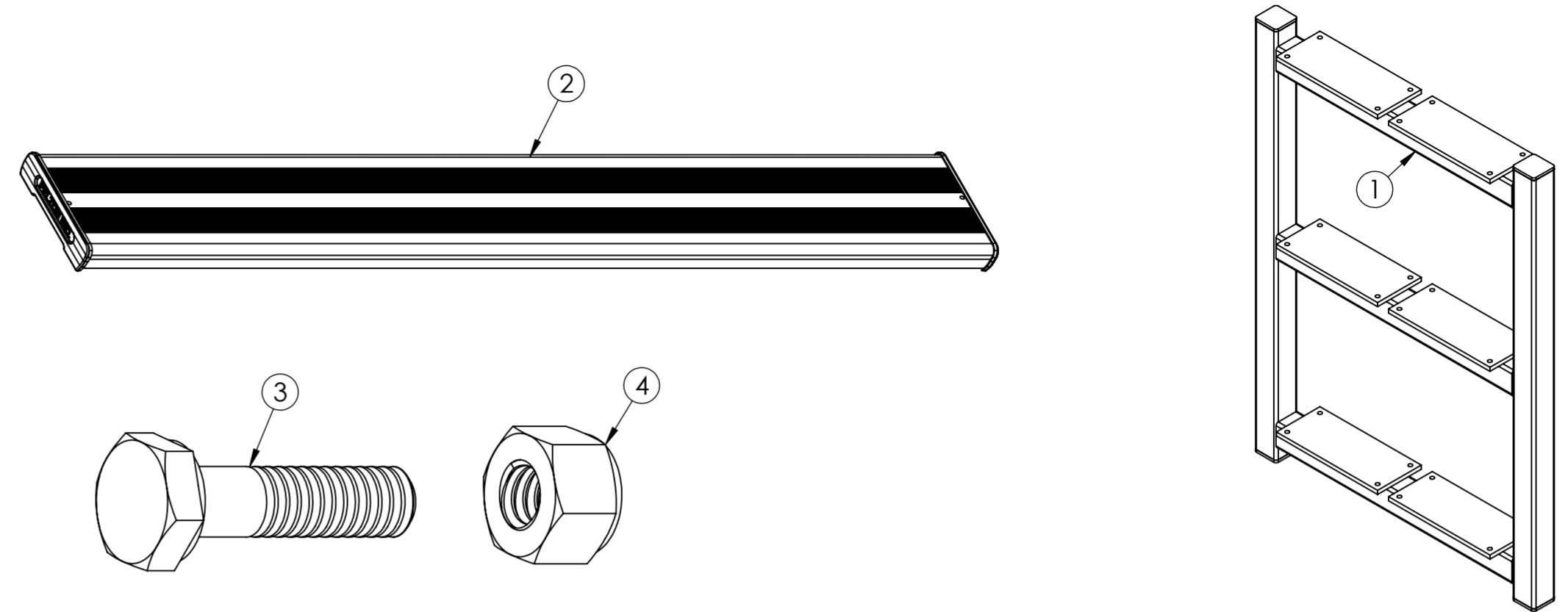

Place two planks (2) upside down and close together on the flat ground as illustrated.

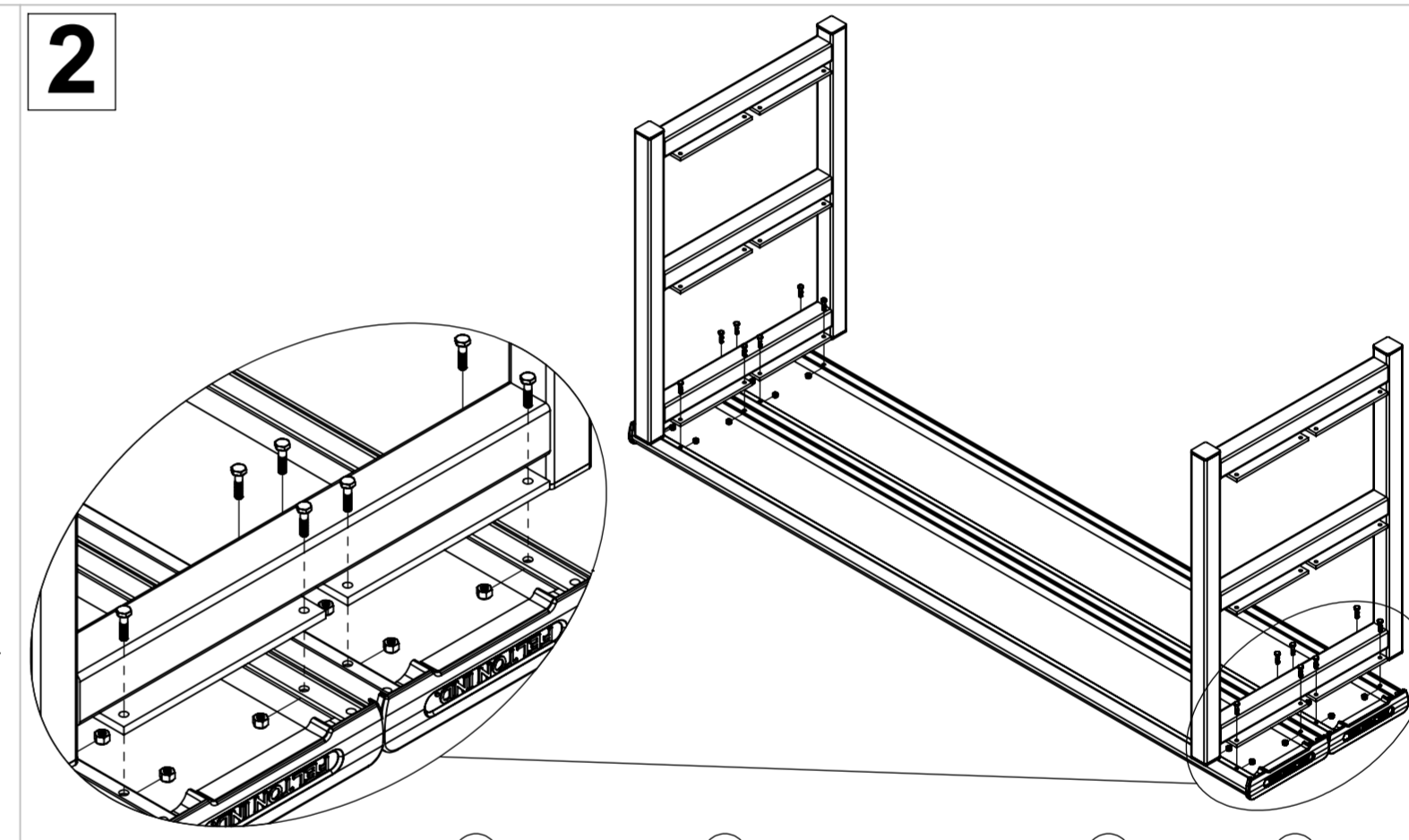

Attach two main frames (1) to two planks (2) in step 1 by using bolts (3) and nuts (4) as illustrated.

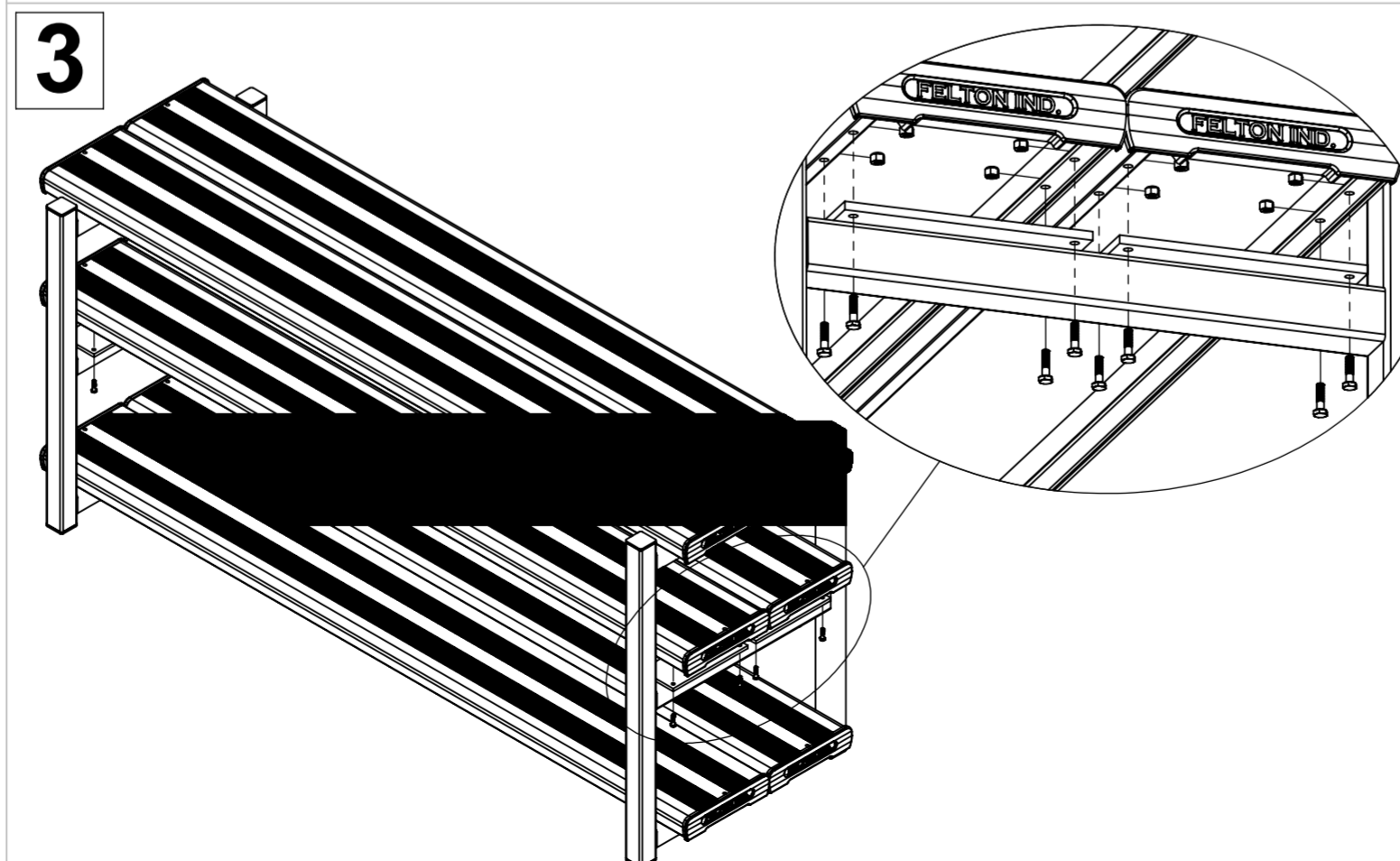

Repeat step 2 with four remaining planks (2) as illustrated.

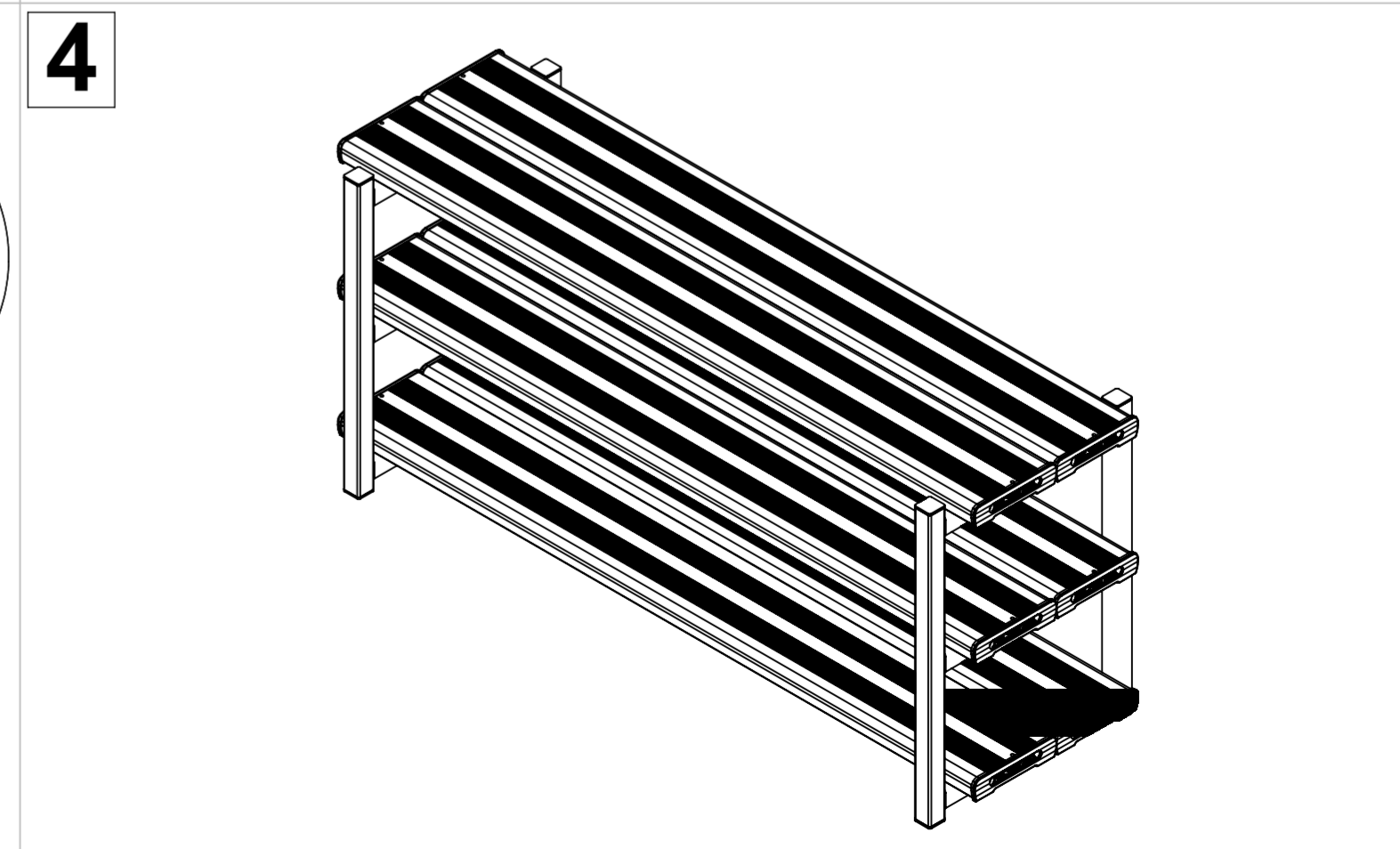

Tighten all hexagonal head bolts with spanners and appropriate tools.