

# ASSEMBLY INSTRUCTION

*Thank You*

FOR CHOOSING FELTON INDUSTRIES

**KIDS EZYCLEAN ART TABLE**  
[Code No: EZYART12LT]



"This product has been manufactured in Australia to the highest quality standard, guaranteeing proven quality, durability and low maintenance"



☎ 1800 22 00 55

🖨 1800 05 91 58

✉ sales@felton.net.au

🌐 www.felton.net.au



Felton Industries Pty Ltd | ABN: 17 130 687 240



**WARNING:** This assembly required two or more people as lifting is involved. **Please ensure bolts and nuts are only finger-tightened throughout assembly for flexibility in lining up components.** Bolt and nuts should be securely tightened in place when instructed to do so. Please check all components are included before proceeding with the assembly

ITEM	DESCRIPTION	Qty
1	EZYART12LT_MAIN FRAME	2
2	EZYART12LT_TABLE TOP	1
3	AS 1112 Bolt - 3/8" x 3"	4
4	AS 1112 Nut - 3/8"	4

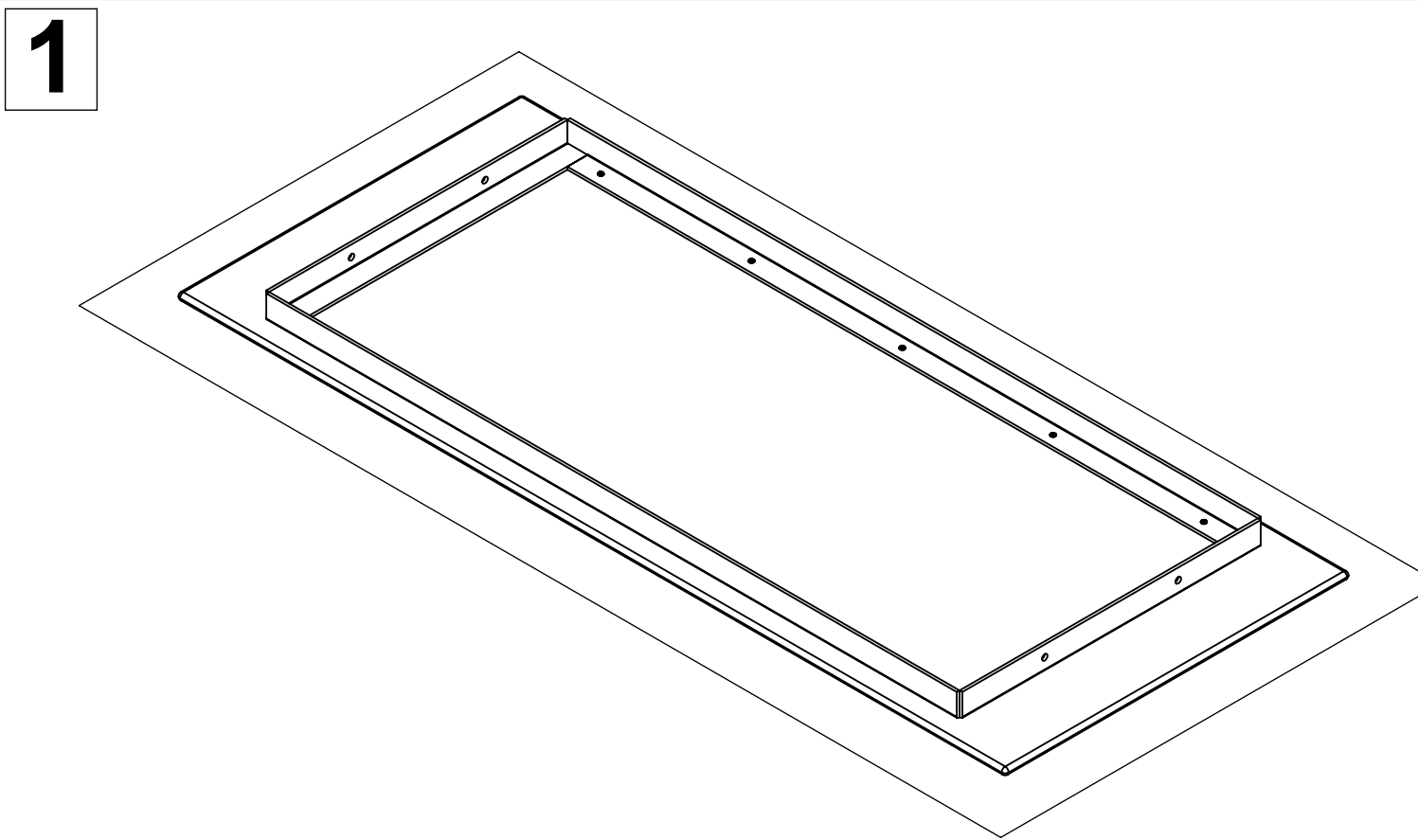
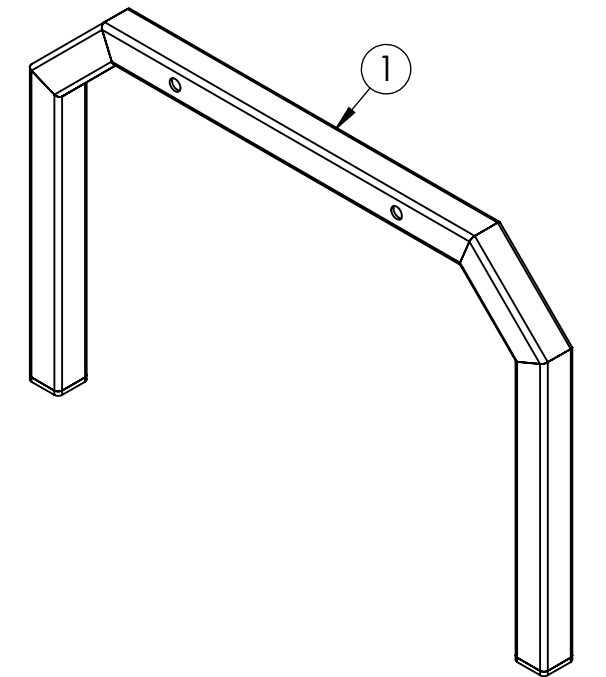
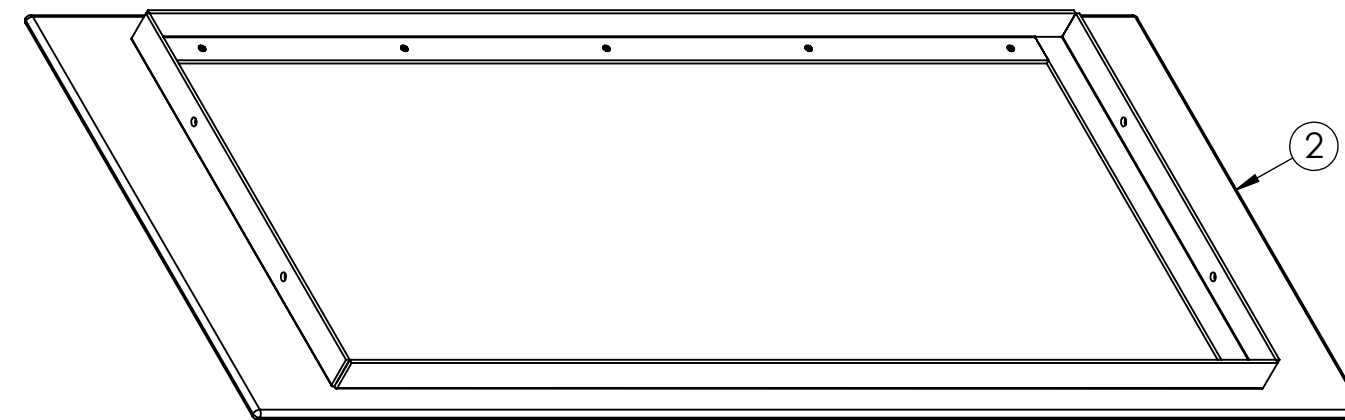
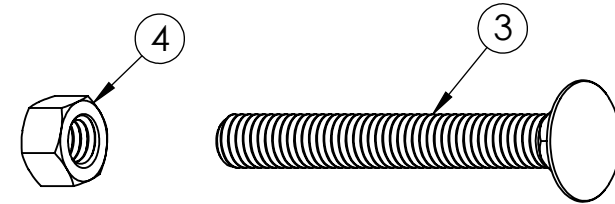

Place the table top (2) upside down on the ground.

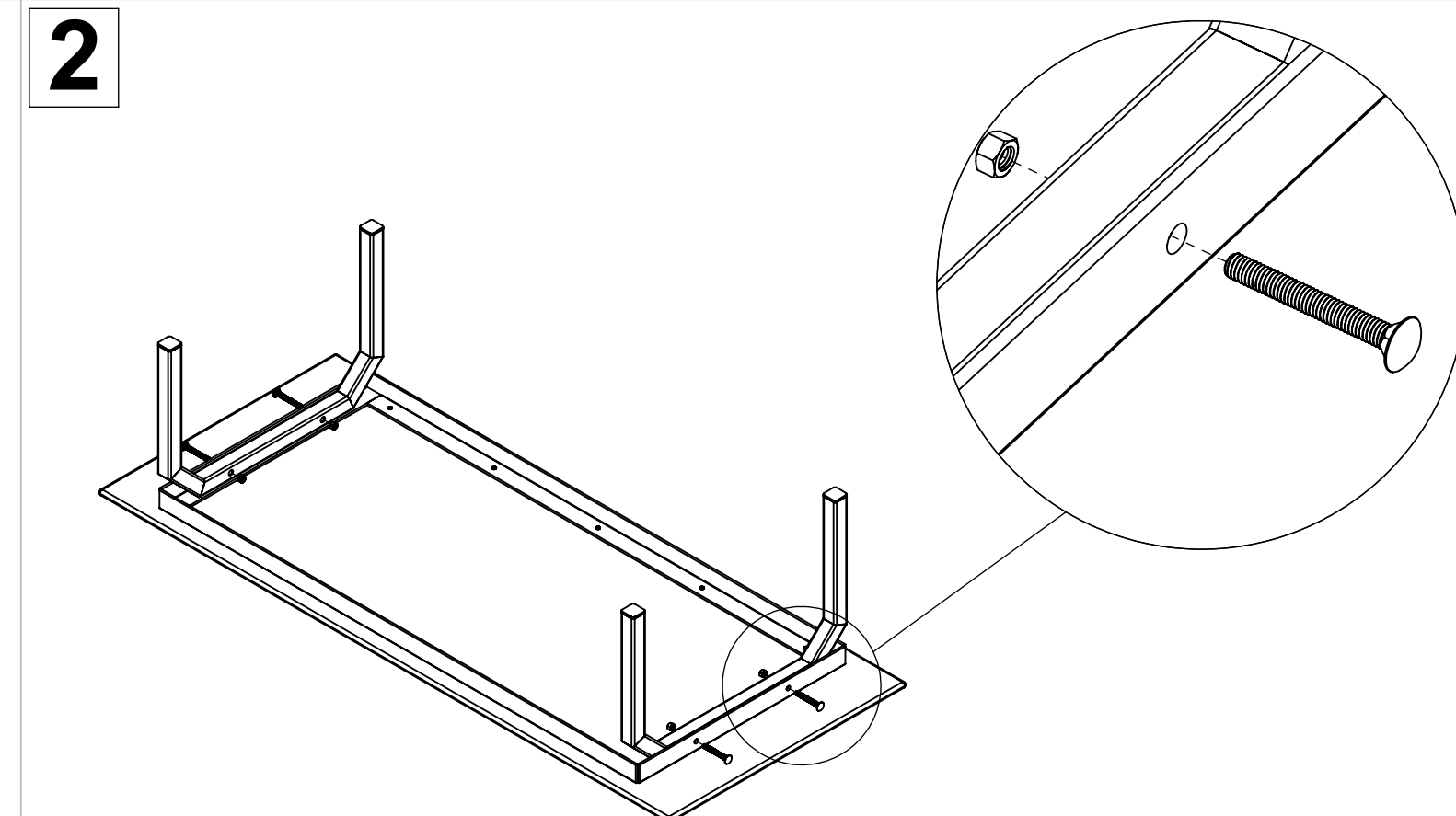

Attach two main frames (1) to the table top (2) in step 1 by using bolts (3) and nuts (4) as illustrated.

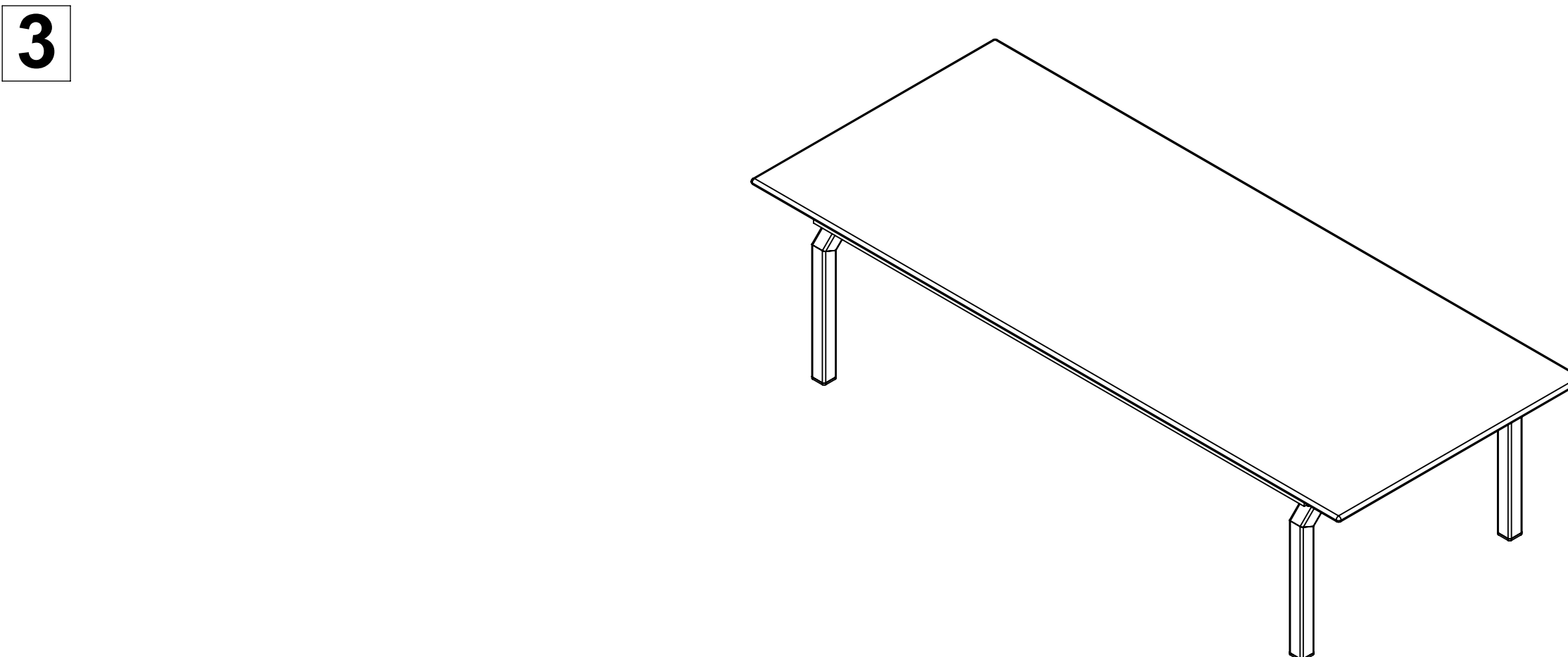

Tighten all hexagonal head bolts with spanners and appropriate tools. Then turn the assembly up