

ASSEMBLY INSTRUCTION

Thank You

FOR CHOOSING FELTON INDUSTRIES

KIDS SNACK BAR SETTING - SIZE 1
[Code No: EZYSBS2250]



"This product has been manufactured in Australia to the highest quality standard, guaranteeing proven quality, durability and low maintenance"



☎ 1800 22 00 55

🖨 1800 05 91 58

✉ sales@felton.net.au

🌐 www.felton.net.au



Felton Industries Pty Ltd | ABN: 17 130 687 240



WARNING: This assembly required two or more people as lifting is involved. Please ensure bolts and nuts are only finger-tightened throughout assembly for flexibility in lining up components. Bolt and nuts should be securely tightened in place when instructed to do so. Please check all components are included before proceeding with the assembly

ITEM	DESCRIPTION	Qty
1	EZYSBS2250_TABLE LEG SUPPORT	2
2	EZYSBS2250_SEAT LEG SUPPORT	4
3	EZYSBS2250_TABLE PLANK L1200	2
4	EZYSBS2250_SEAT PLANK L900	2
5	AS-NZS 2465 Bolt - 1/4" x 1"	32
6	AS-NZS NYLON Nut - 1/4"	32

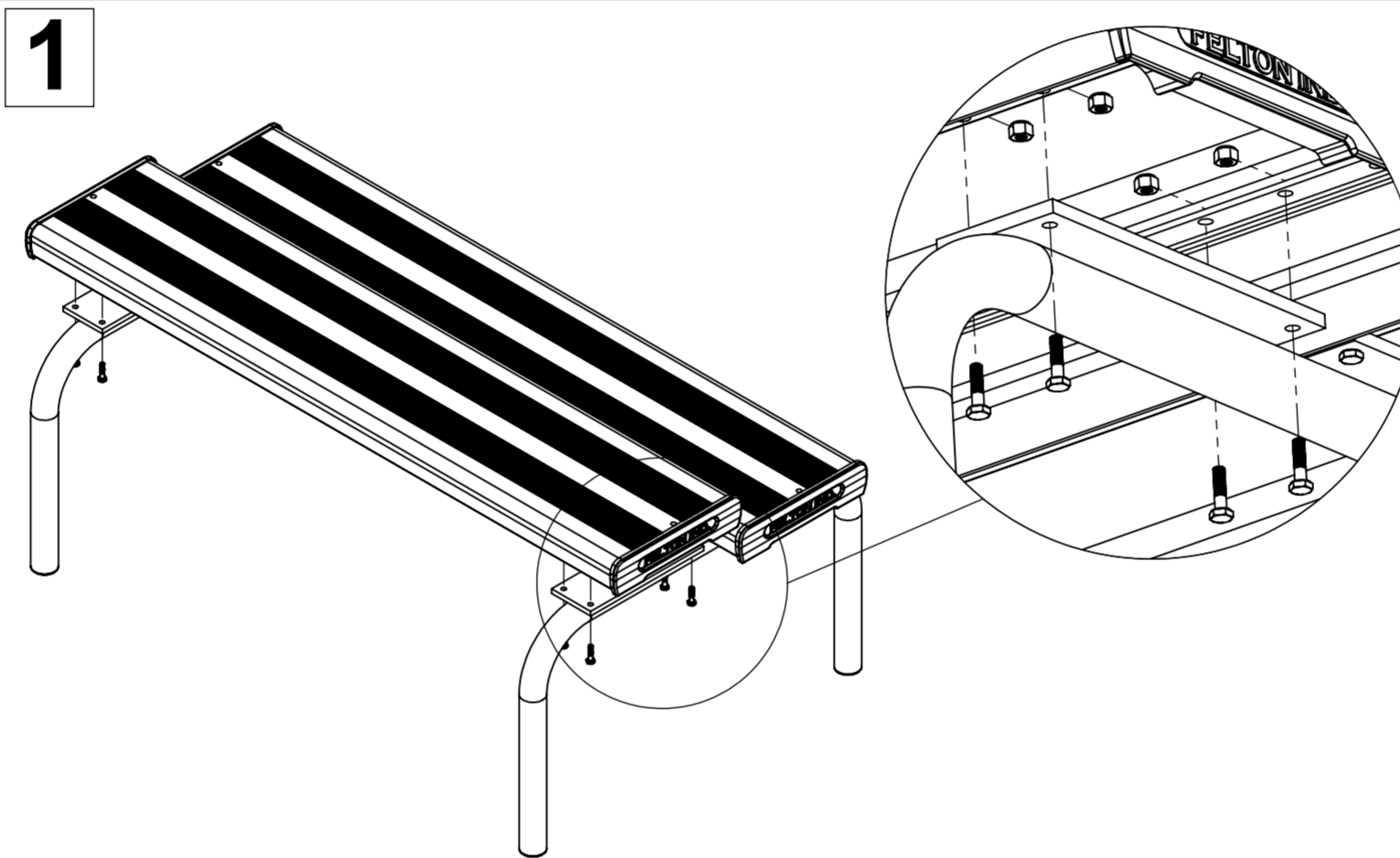
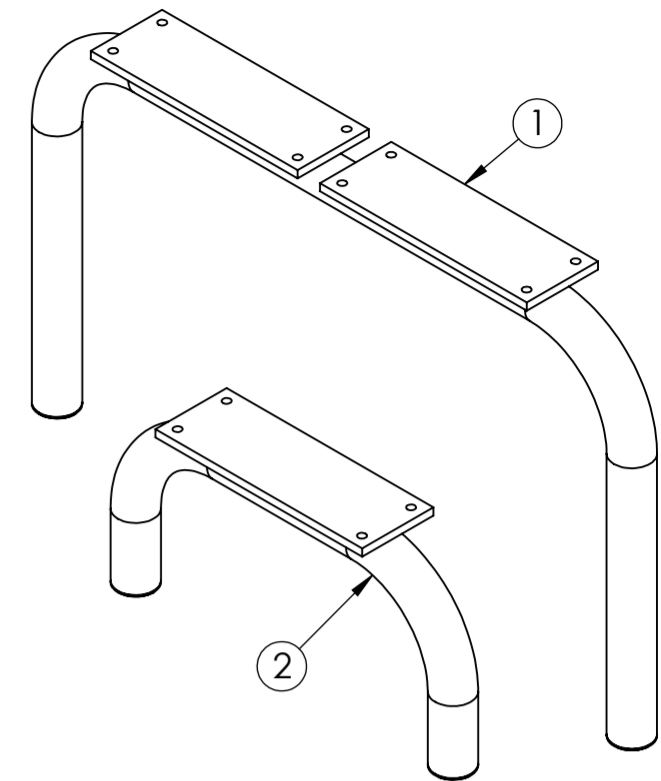
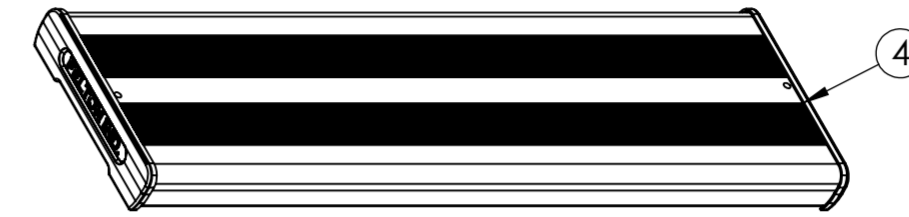
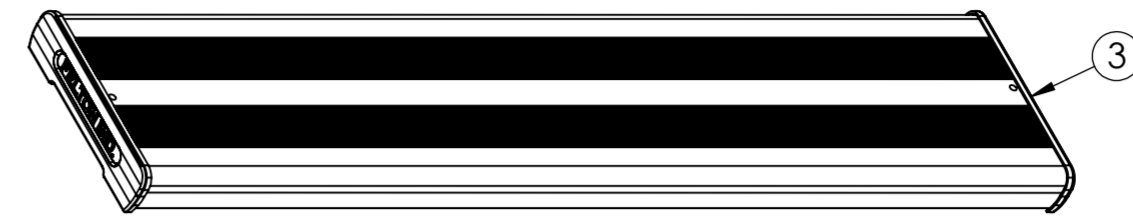
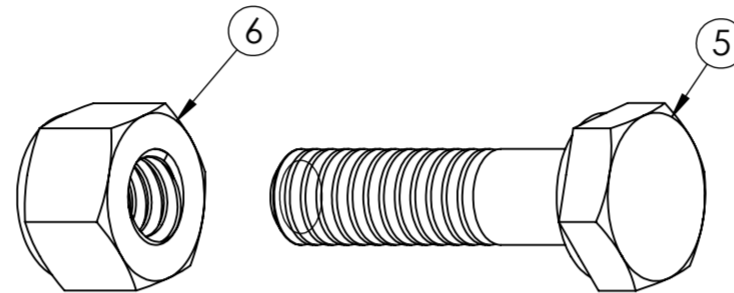

Attach two table planks (3) to two table leg supports (1) by using bolts (5) and nuts (6) as illustrated.

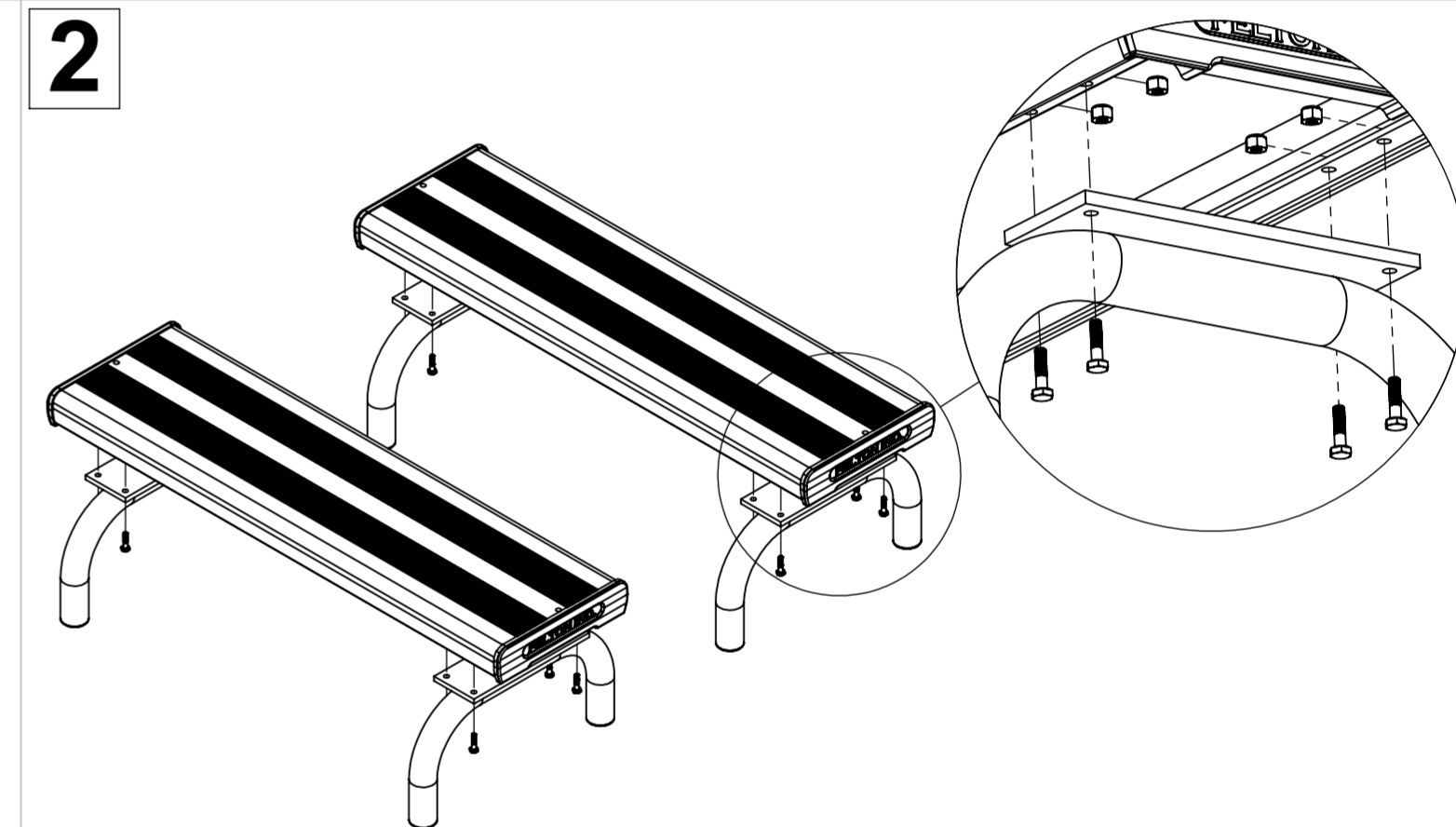

Attach two seat planks (4) to four seat leg supports (2) to create two side seats by using bolts (5) and nuts (6) as illustrated.

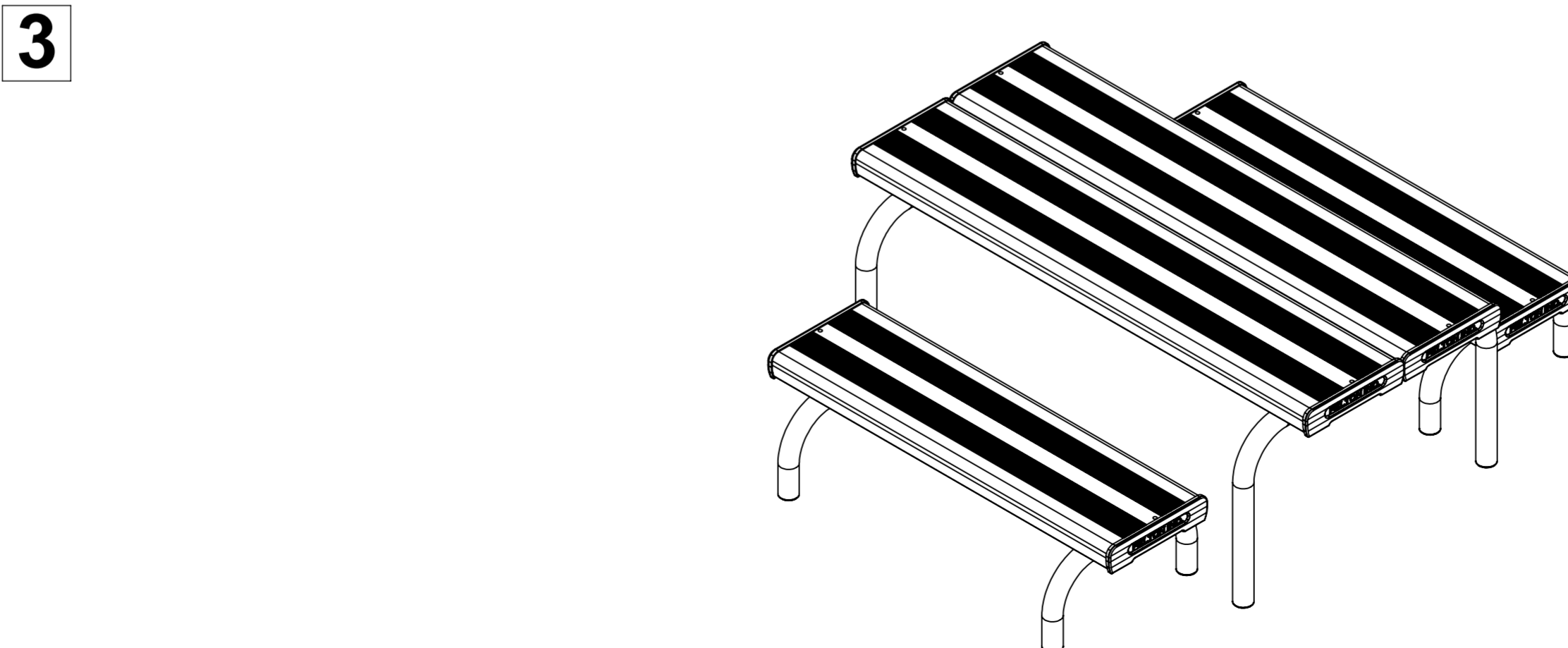

Tighten all hexagonal head bolts with spanners and appropriate tools. Then arrange all assemblies in previous steps as illustrated.