

# ASSEMBLY INSTRUCTION

*Thank You*

FOR CHOOSING FELTON INDUSTRIES

**KIDS PARTY SIZE SNACK BAR  
SETTING - SIZE 2  
[Code No: EZYSBS4300]**



"This product has been manufactured in Australia to the highest quality standard, guaranteeing proven quality, durability and low maintenance"



☎ 1800 22 00 55

🖨 1800 05 91 58

✉ sales@felton.net.au

🌐 www.felton.net.au



Felton Industries Pty Ltd | ABN: 17 130 687 240



**WARNING:** This assembly required two or more people as lifting is involved. Please ensure bolts and nuts are only finger-tightened throughout assembly for flexibility in lining up components. Bolt and nuts should be securely tightened in place when instructed to do so. Please check all components are included before proceeding with the assembly

ITEM	DESCRIPTION	Qty
1	EZYSBS4300_TABLE LEG SUPPORT	2
2	EZYSBS4300_SEAT LEG SUPPORT	8
3	EZYSBS4300_TABLE PLANK L1500	2
4	EZYSBS4300_SEAT PLANK L1200	2
5	EZYSBS4300_SEAT PLANK L500	2
6	AS-NZS 2465 Bolt - 1/4" x 1"	48
7	AS-NZS NYLON Nut - 1/4"	48

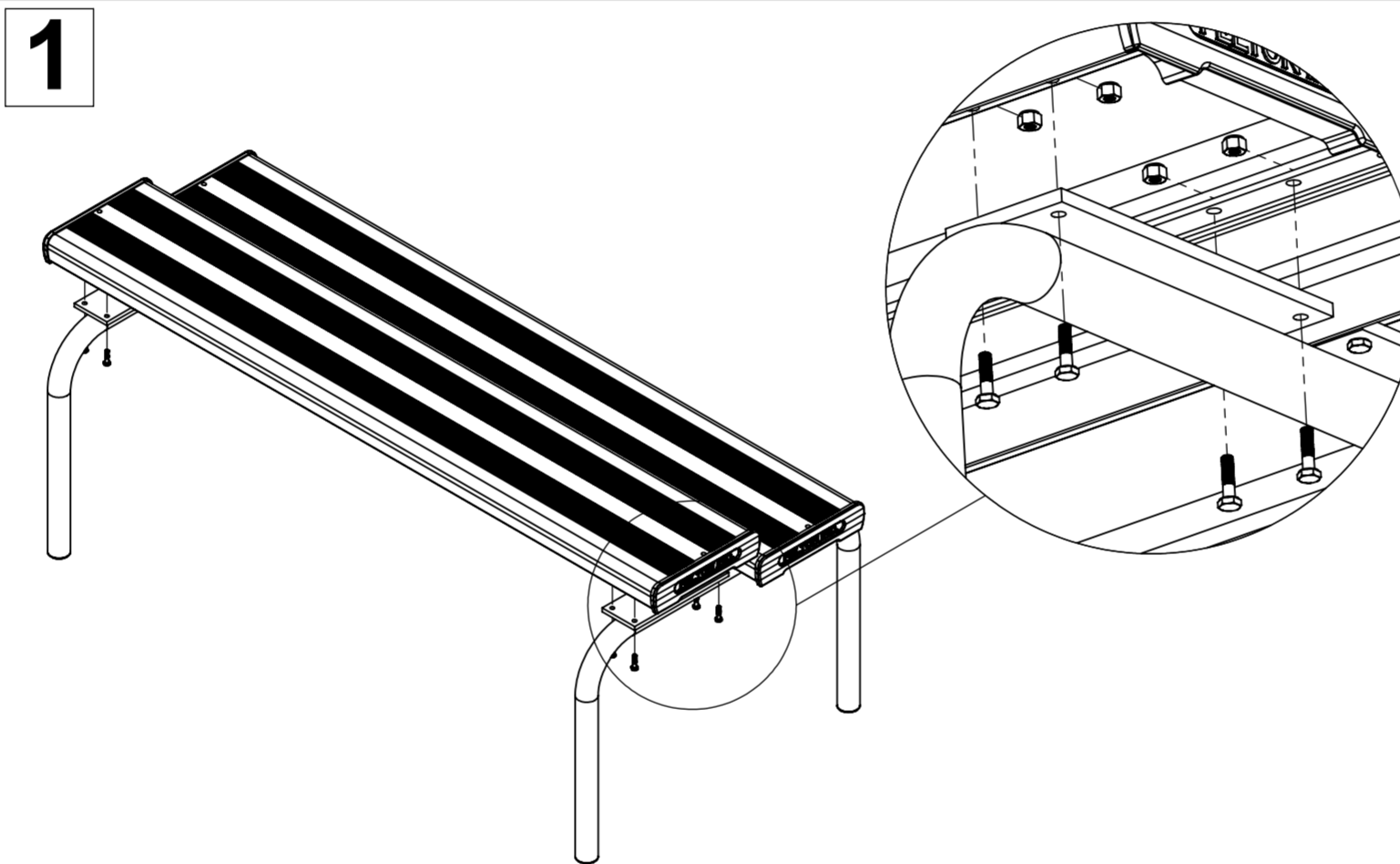
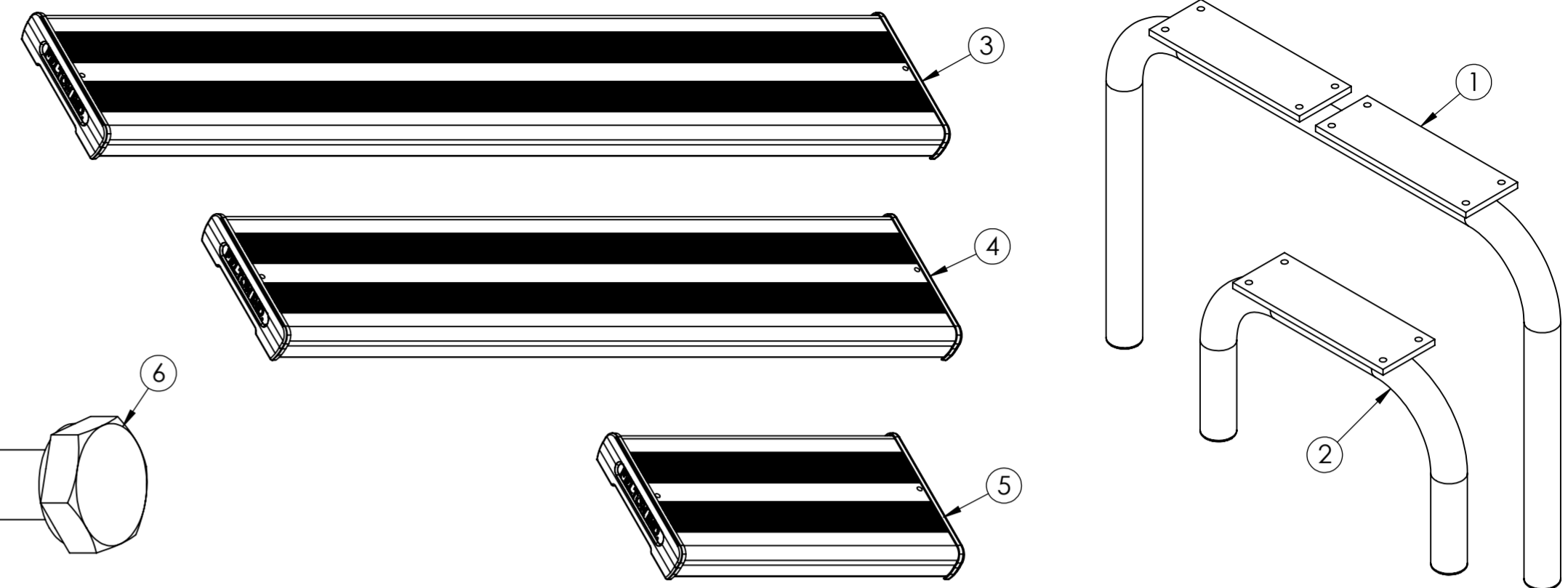
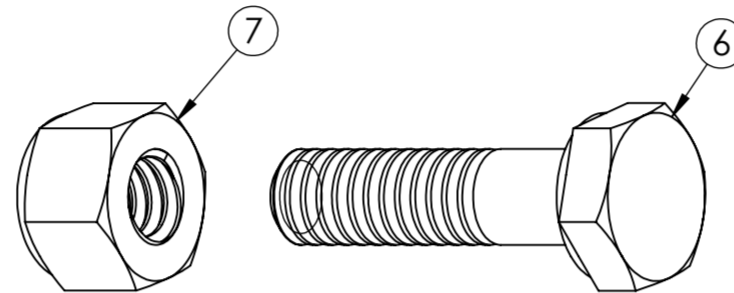

Attach two table planks (3) to two table leg supports (1) by using bolts (6) and nuts (7) as illustrated.

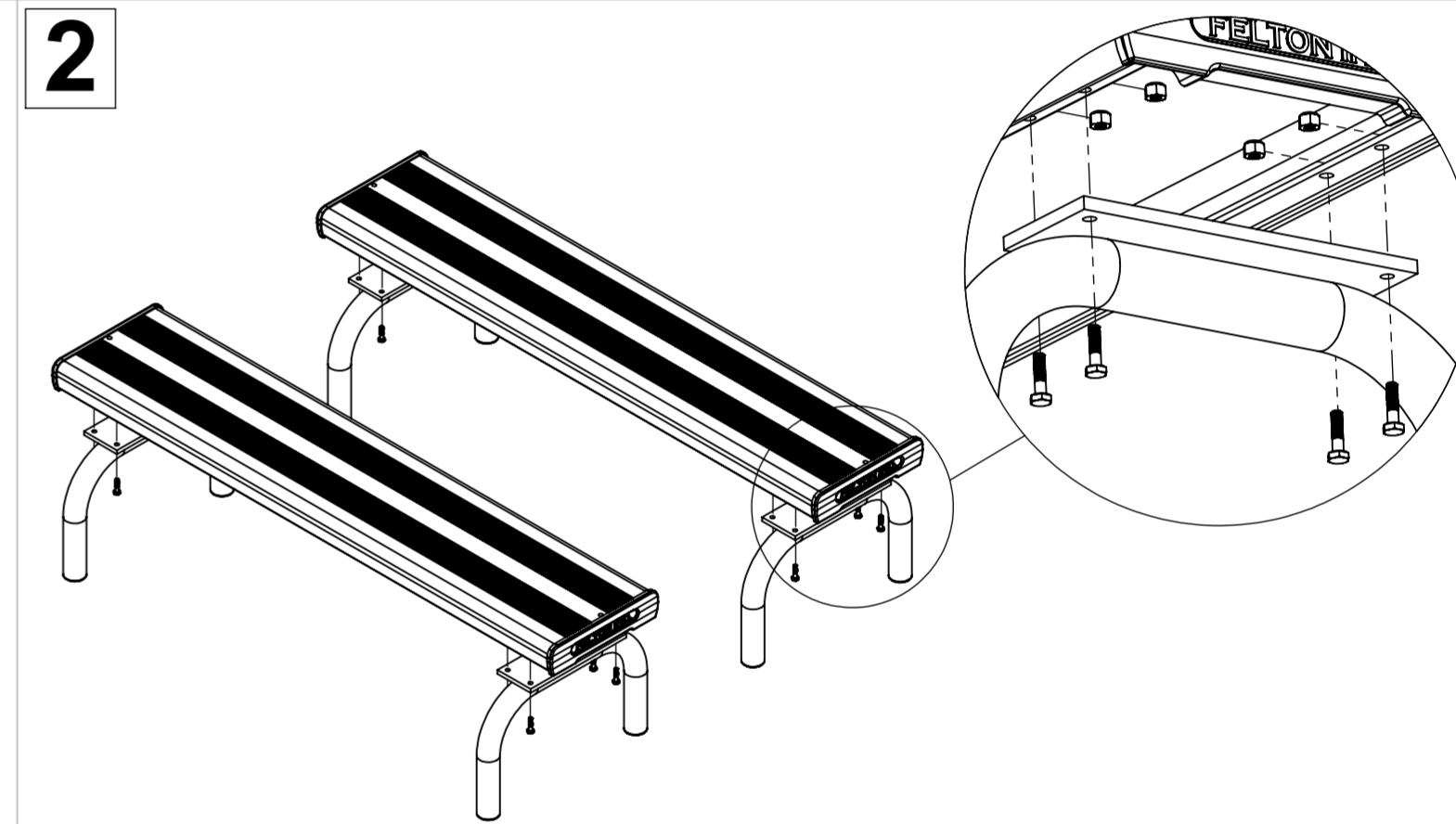

Attach two seat planks (4) to four seat leg supports (2) to create two side seats by using bolts (6) and nuts (7) as illustrated.

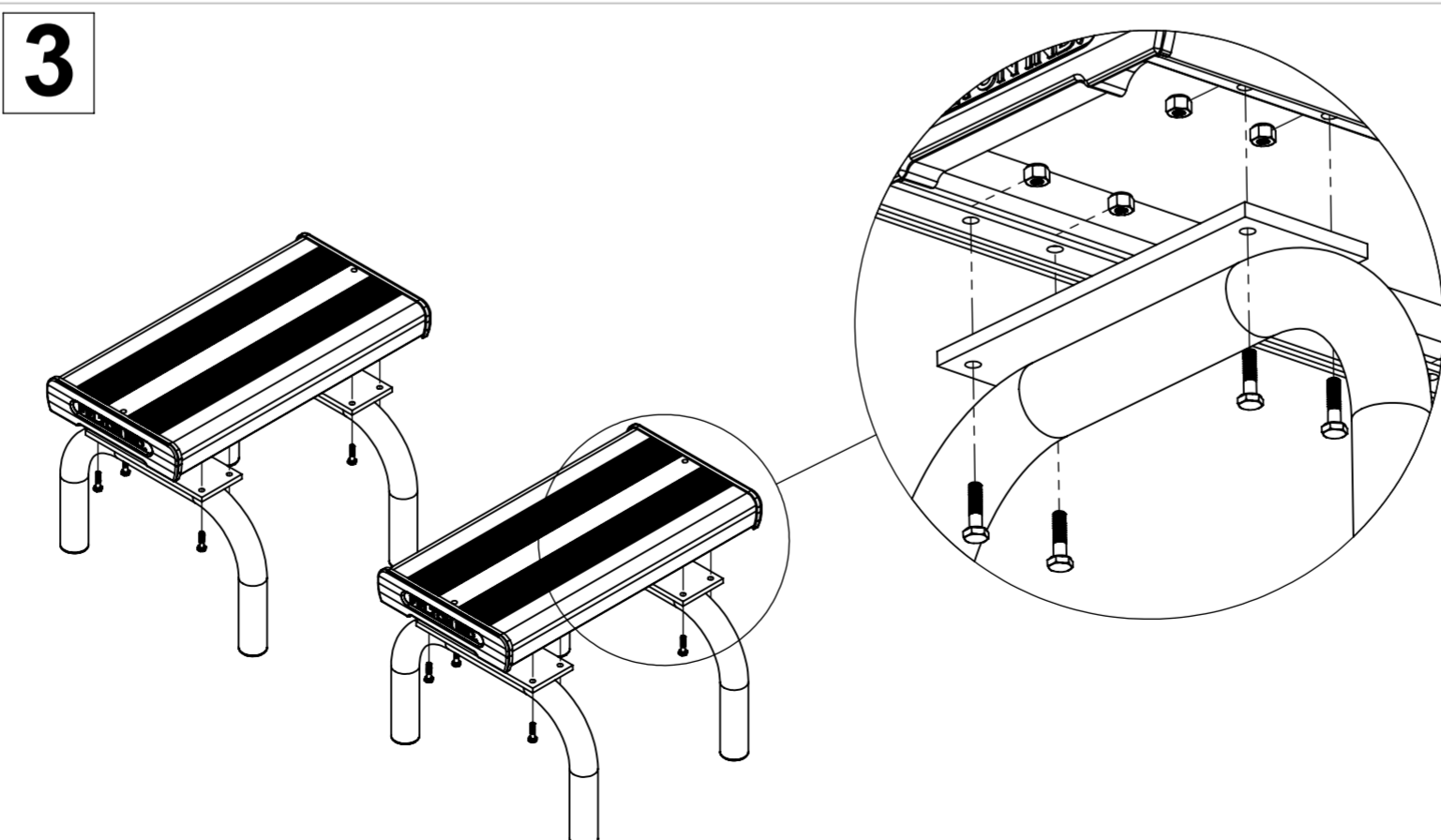

Attach two seat planks (5) to four seat leg supports (2) to create two end seats by using bolts (6) and nuts (7) as illustrated.

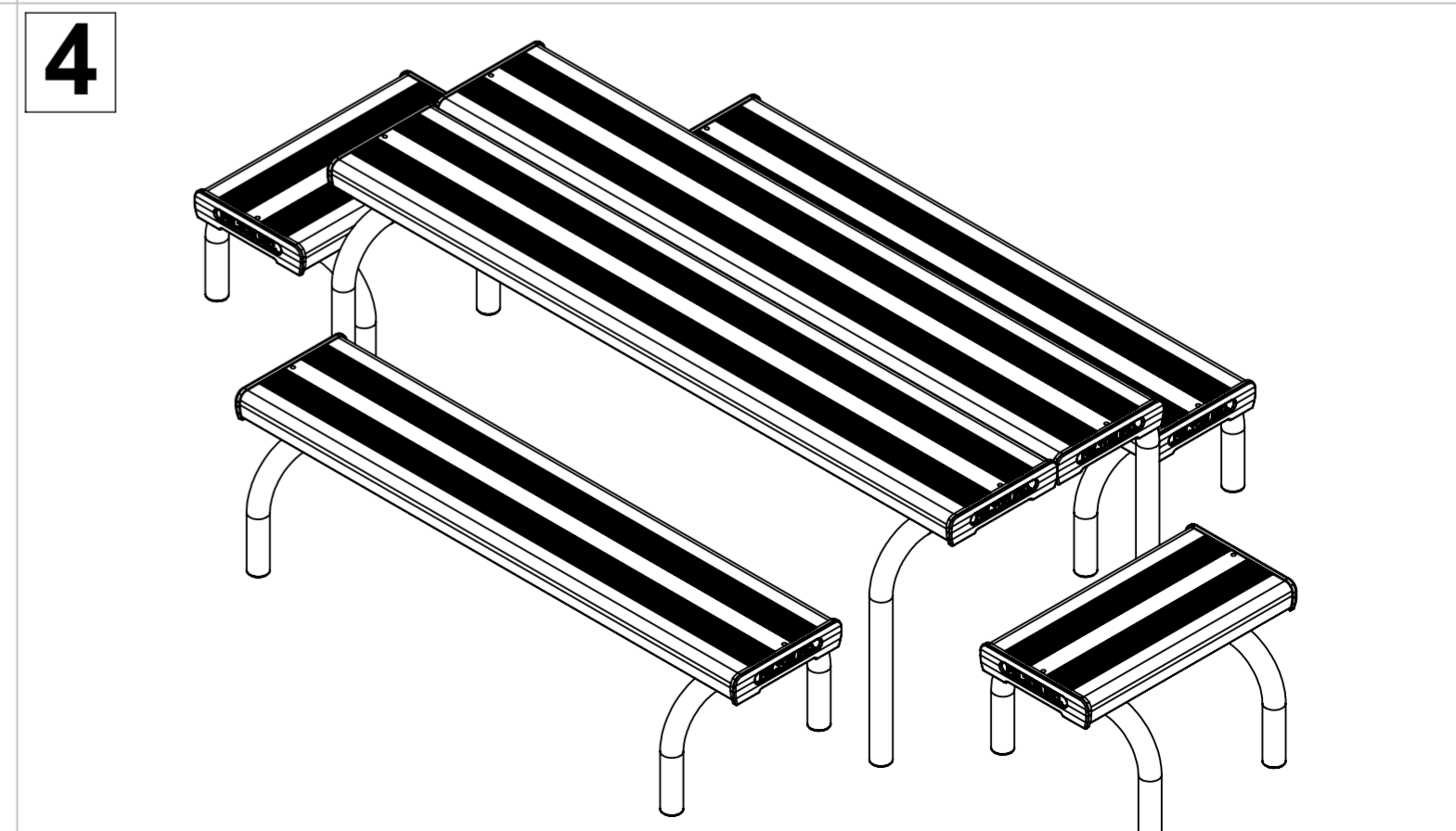

Tighten all hexagonal head bolts with spanners and appropriate tools. Then arrange all assemblies in previous steps as illustrated.