

ASSEMBLY INSTRUCTION

Thank You

FOR CHOOSING FELTON INDUSTRIES

**ABOVE GROUND BUDDY BENCH
WITH BACKREST**
[Code No: FELAGB2-BB]



"This product has been manufactured in Australia to the highest quality standard, guaranteeing proven quality, durability and low maintenance"



☎ 1800 22 00 55

🖨 1800 05 91 58

✉ sales@felton.net.au

🌐 www.felton.net.au



Felton Industries Pty Ltd | ABN: 17 130 687 240



WARNING: This assembly required two or more people as lifting is involved. **Please ensure bolts and nuts are only finger-tightened throughout assembly for flexibility in lining up components.** Bolt and nuts should be securely tightened in place when instructed to do so. Please check all components are included before proceeding with the assembly

ITEM	DESCRIPTION	Qty
1	FELAGBLS_ABOVE GROUND LEG SUPPORT	2
2	FEL-BB_BUDDY SEAT PLANK L2000	1
3	FEL-BB_BUDDY BACKREST PLANK L2000	1
4	FEL-BB_BUDDY ARMREST	2
5	AS-NZS 2465 Bolt - 1/4" x 1"	20
6	AS-NZS NYLON Nut - 1/4"	20

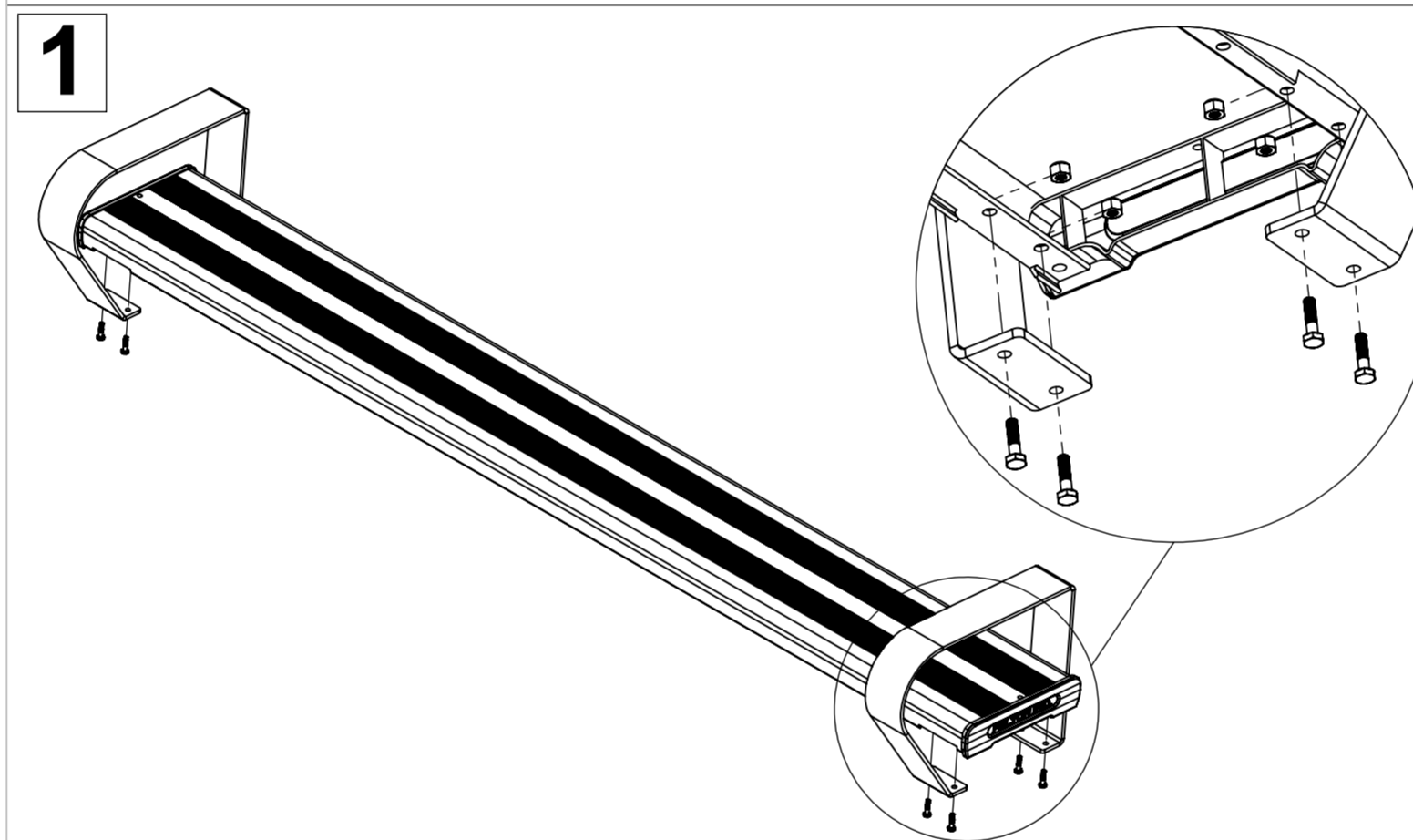
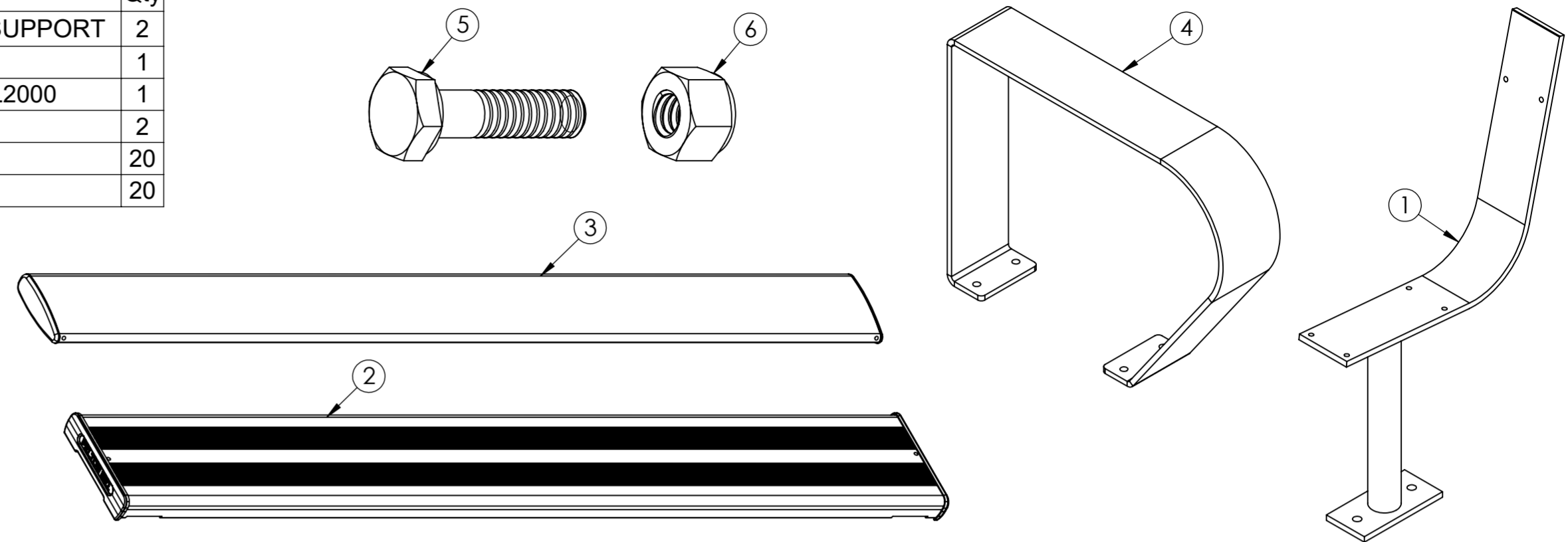

Attach two armrests (4) to the seat plank (2) by using bolts (5) and nuts (6) as illustrated.

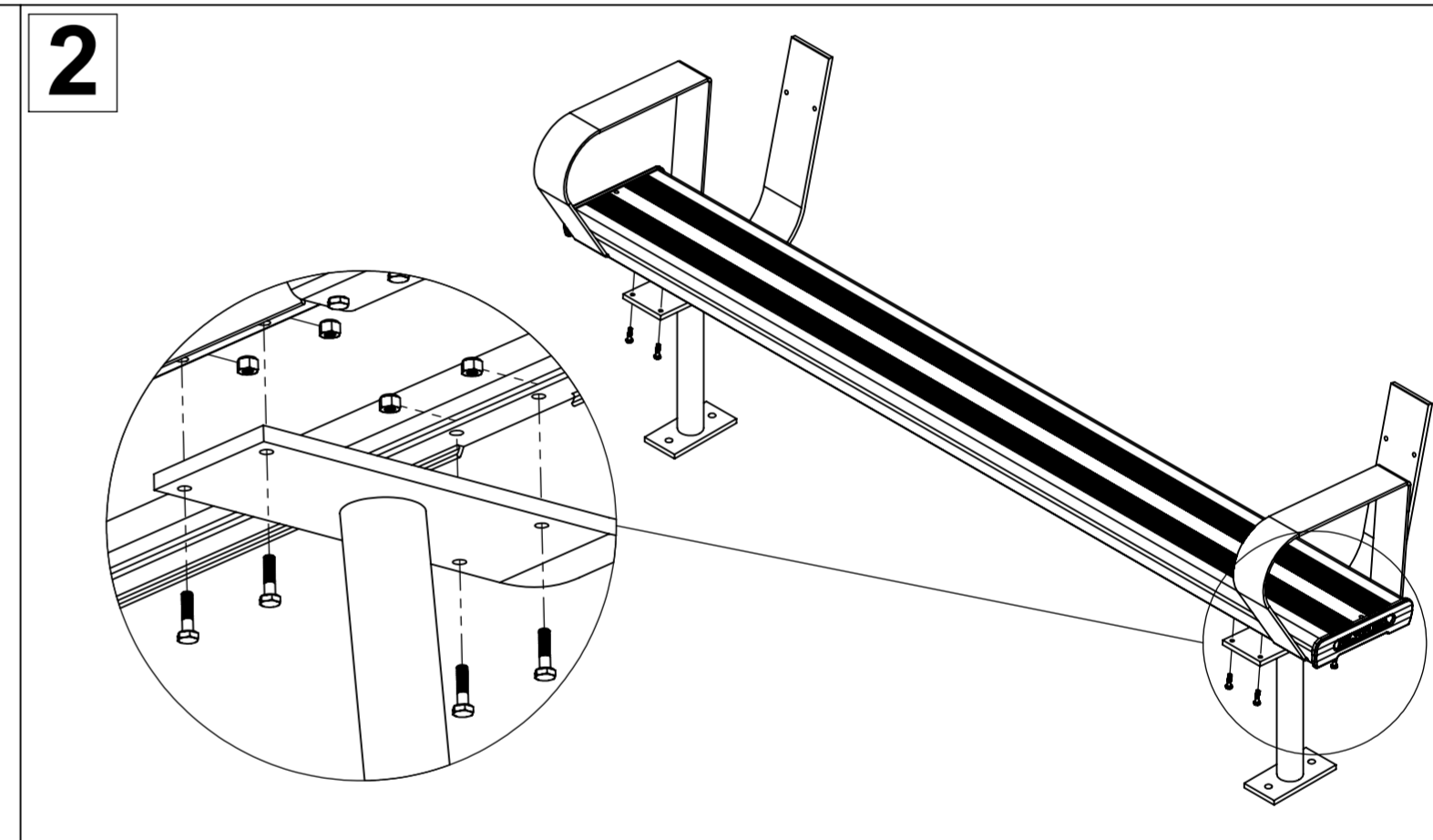

Attach the assembly in step 1 to two leg supports (1) by using bolts (5) and nuts (6) as illustrated.

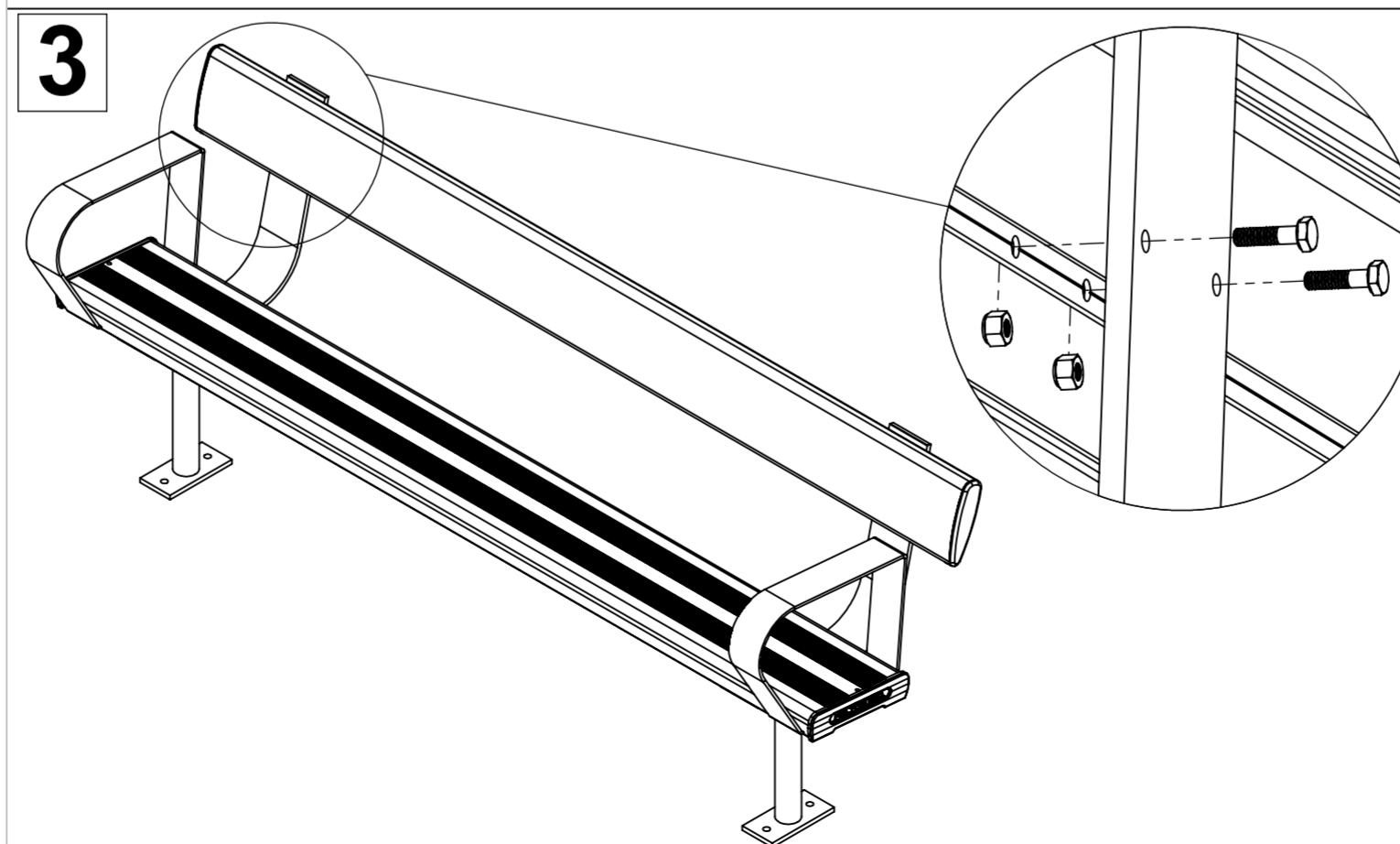

Attach the backrest plank (3) to the assembly in step 2 by using bolts (5) and nuts (6) as illustrated.

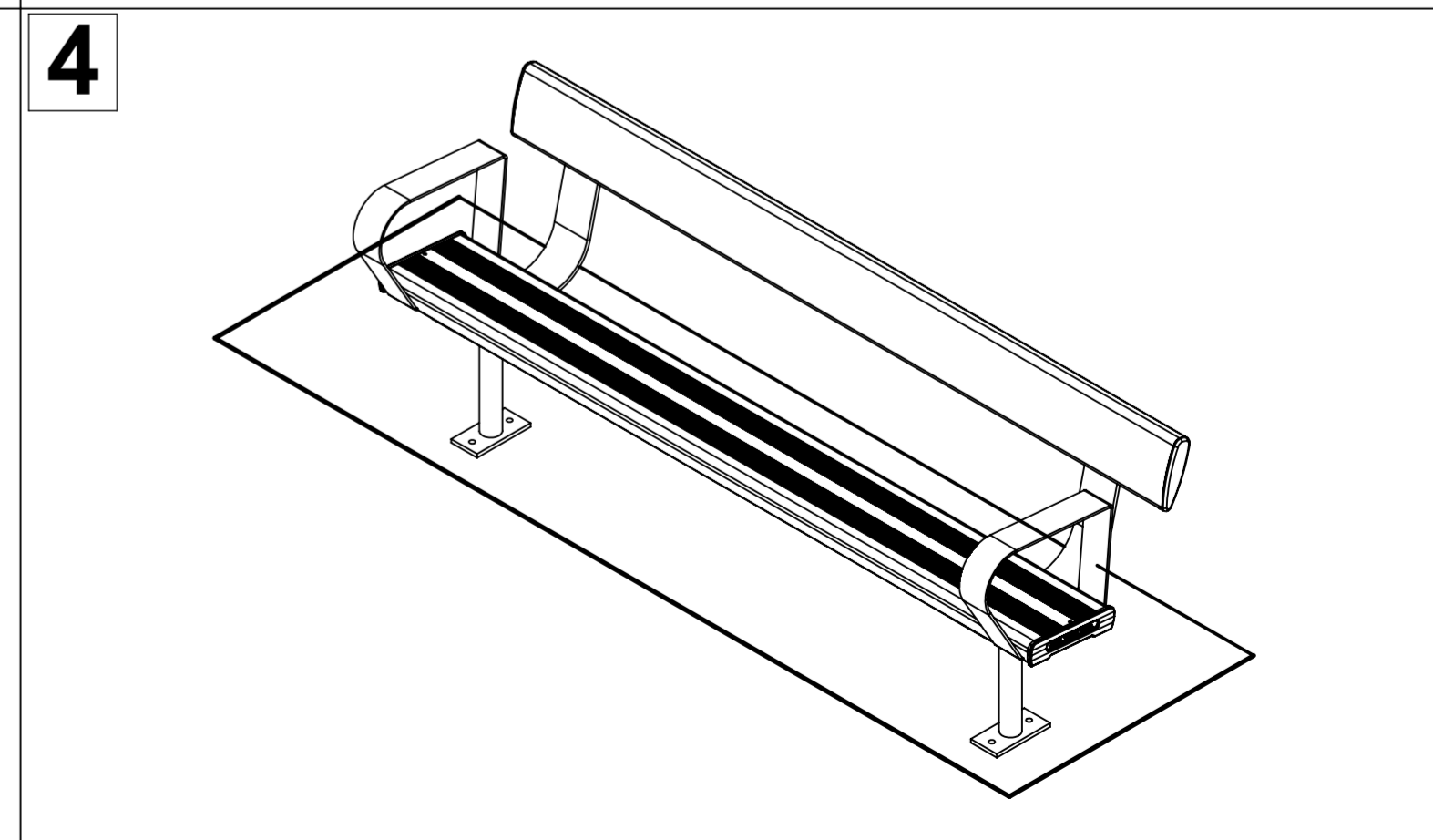

Tighten all hexagonal head bolts with spanners and appropriate tools. Then attach the whole assembly to the ground by using M12 dyna-bolts preferably, on each frame lug.