

ASSEMBLY INSTRUCTION

Thank You

FOR CHOOSING FELTON INDUSTRIES

**ABOVE GROUND BACKREST
BENCH SEAT 4mtr
[Code No: FELAGB4]**



"This product has been manufactured in Australia to the highest quality standard, guaranteeing proven quality, durability and low maintenance"



☎ 1800 22 00 55

📠 1800 05 91 58

✉ sales@felton.net.au

🌐 www.felton.net.au



Felton Industries Pty Ltd | ABN: 17 130 687 240



WARNING: This assembly required two or more people as lifting is involved. **Please ensure bolts and nuts are only finger-tightened throughout assembly for flexibility in lining up components.** Bolt and nuts should be securely tightened in place when instructed to do so. Please check all components are included before proceeding with the assembly

ITEM	DESCRIPTION	Qty
1	FELAGBLS_ABOVE GROUND LEG SUPPORT	3
2	FELAGB4_SEAT PLANK L4000	1
3	FELAGB4_BACKREST PLANK L4000	1
4	AS-NZS 2465 Bolt - 1/4" x 1"	18
5	AS-NZS NYLON Nut - 1/4"	18

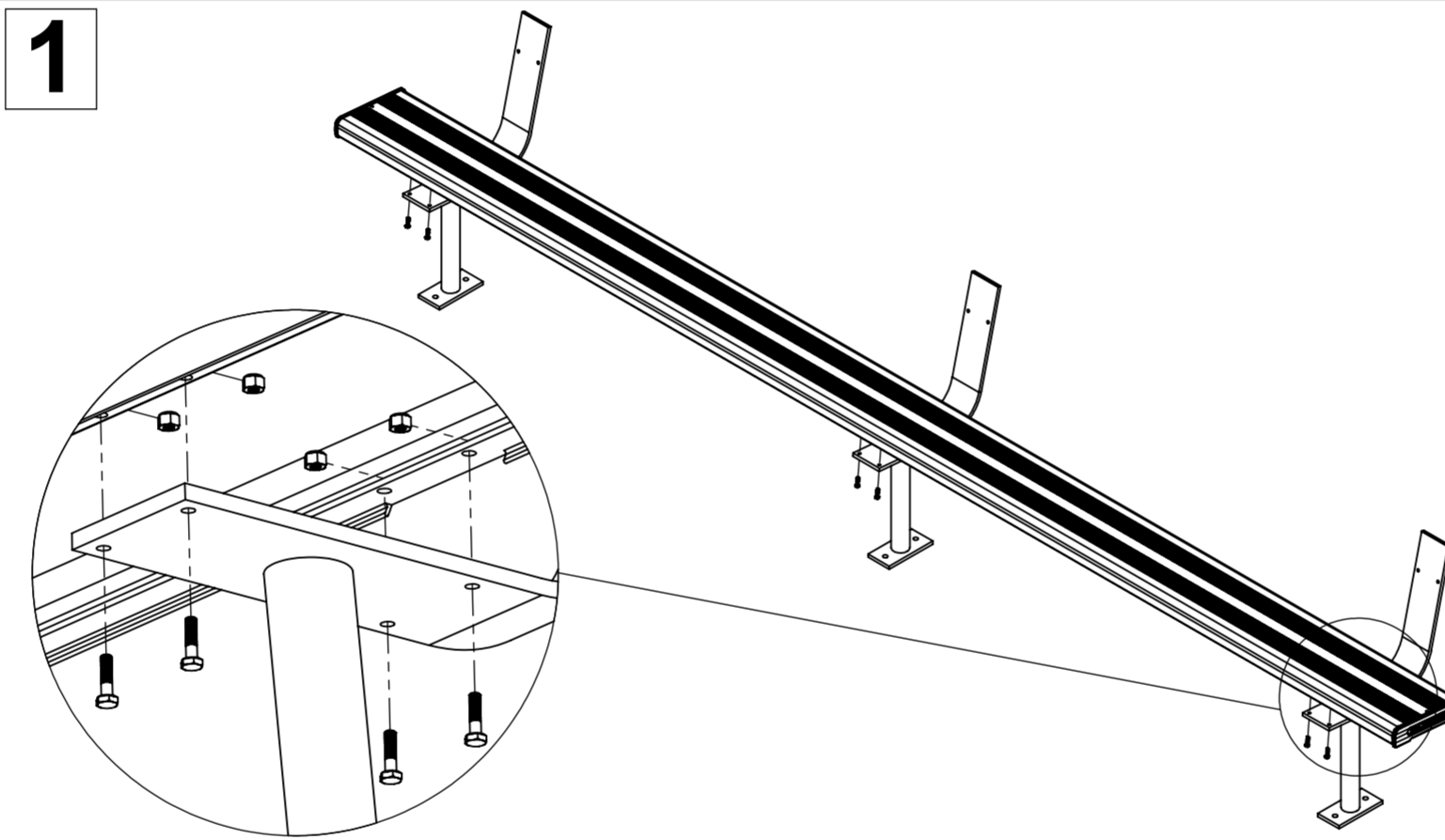
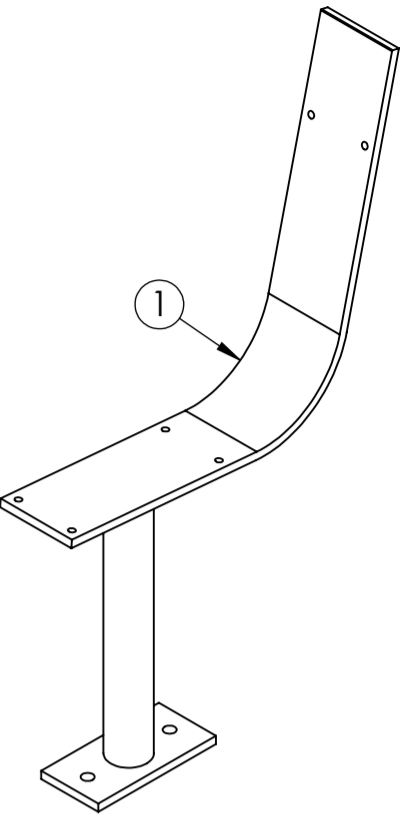
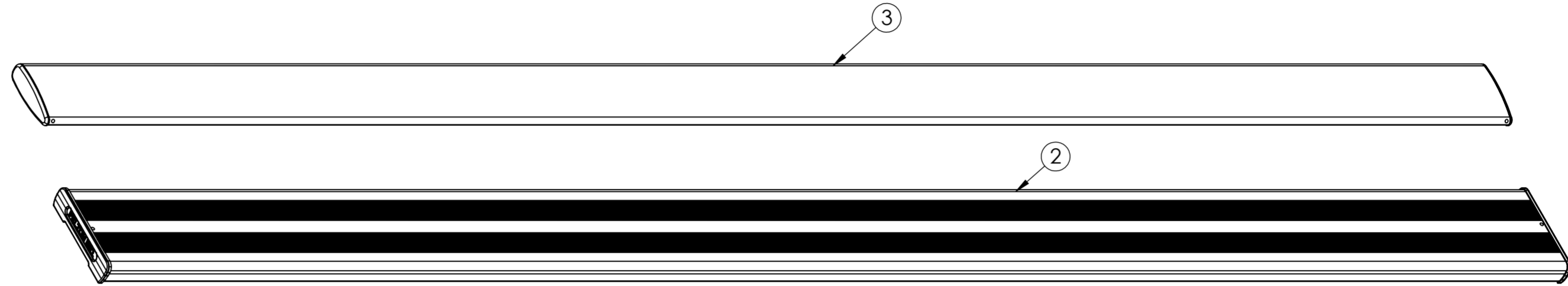
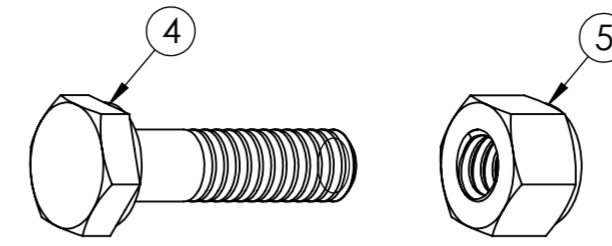

Attach the seat plank (2) to three leg supports (1) by using bolts (4) and nuts (5) as illustrated.

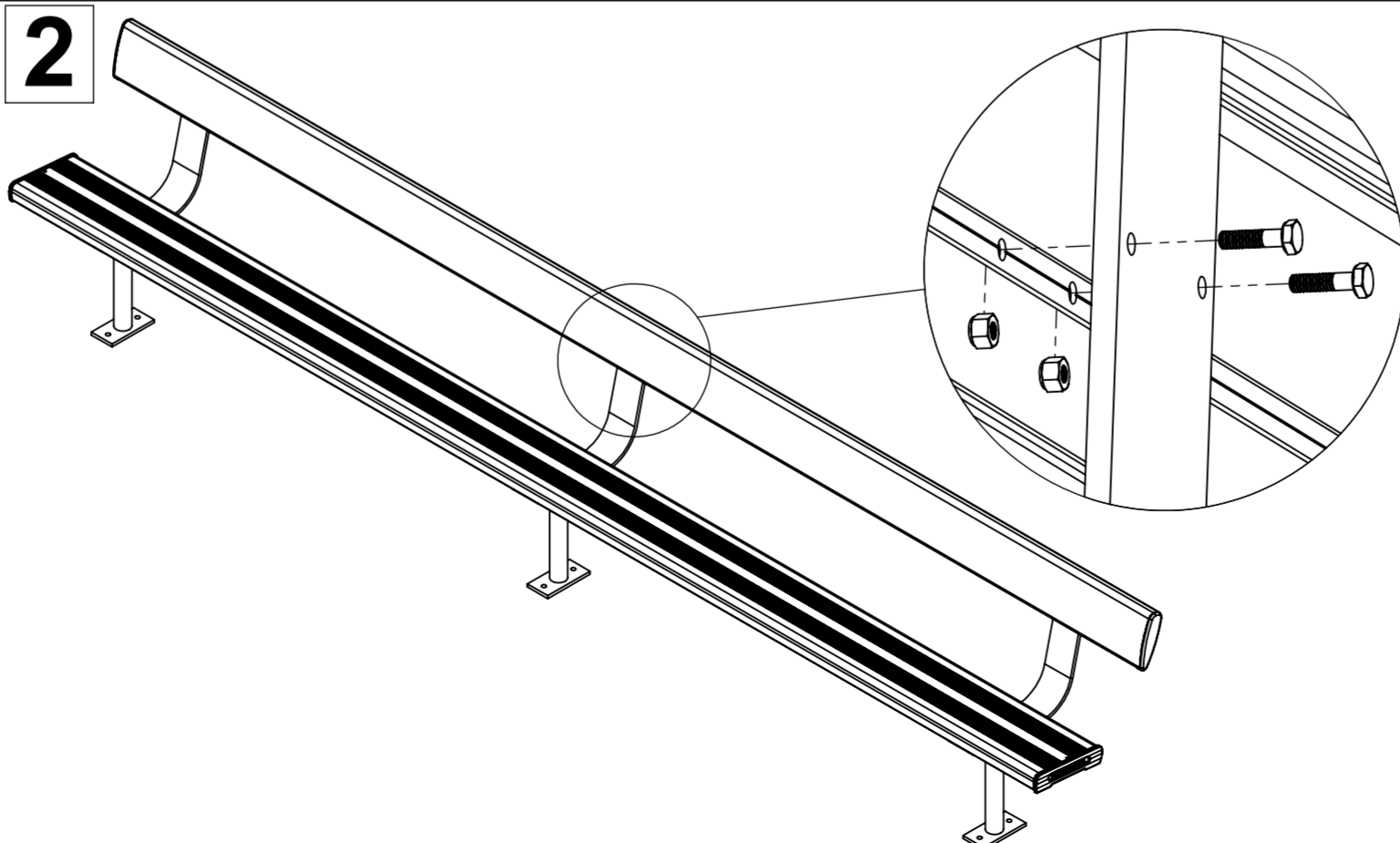

Attach the backrest plank (3) to the assembly in step 1 by using bolts (4) and nuts (5) as illustrated.

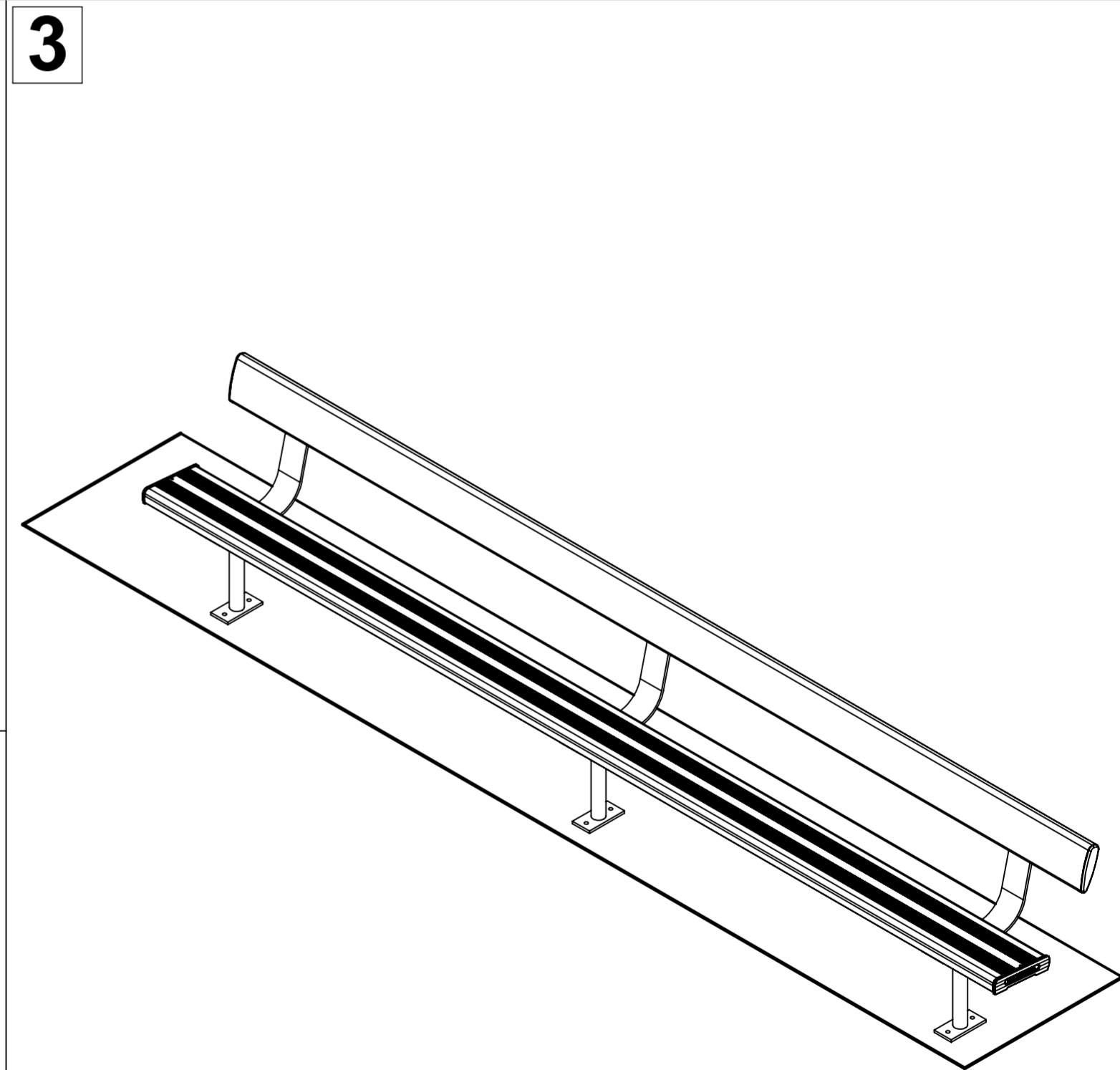

Tighten all hexagonal head bolts with spanners and appropriate tools. Then attach the whole assembly to the ground by using M12 dyna-bolts preferably, on each frame lug.