

ASSEMBLY INSTRUCTION

Thank You

FOR CHOOSING FELTON INDUSTRIES

BOLT DOWN PARK SETTING
[Code No: FELAGPS]



"This product has been manufactured in Australia to the highest quality standard, guaranteeing proven quality, durability and low maintenance"



☎ 1800 22 00 55

📄 1800 05 91 58

✉ sales@felton.net.au

🌐 www.felton.net.au



Felton Industries Pty Ltd | ABN: 17 130 687 240



WARNING: This assembly required two or more people as lifting is involved. Please ensure bolts and nuts are only finger-tightened throughout assembly for flexibility in lining up components. Bolt and nuts should be securely tightened in place when instructed to do so. Please check all components are included before proceeding with the assembly

ITEM	DESCRIPTION	Qty
1	FELAGPS_TABLE FRAME	2
2	FELAGPS_SEAT FRAME	4
3	FELAGPS_TABLE PLANK L1800	3
4	FELAGPS_SEAT PLANK L1800	2
5	AS-NZS 2465 Bolt - 1/4" x 1"	40
6	AS-NZS NYLON Nut - 1/4"	40

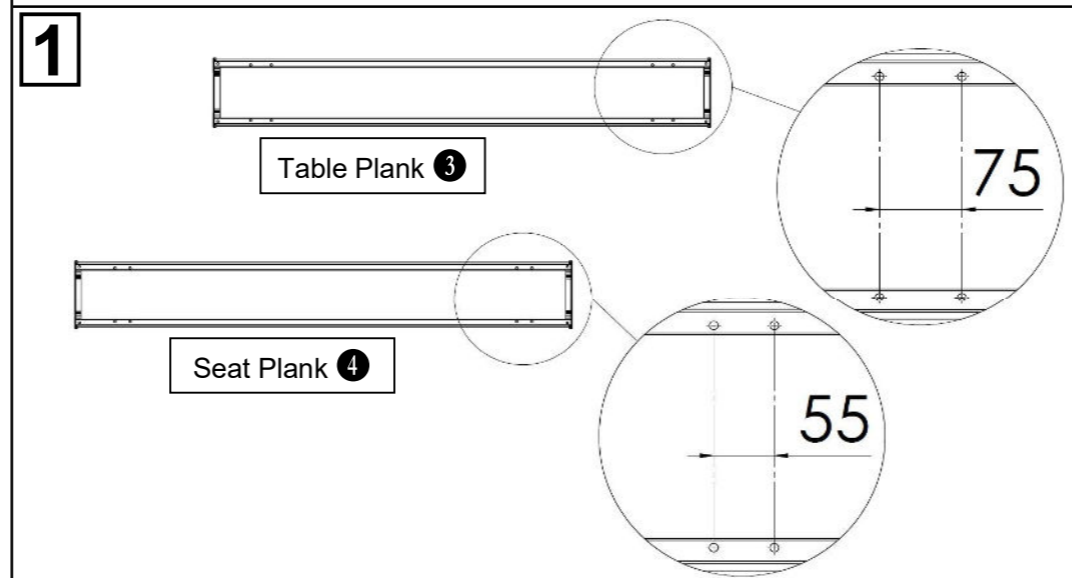
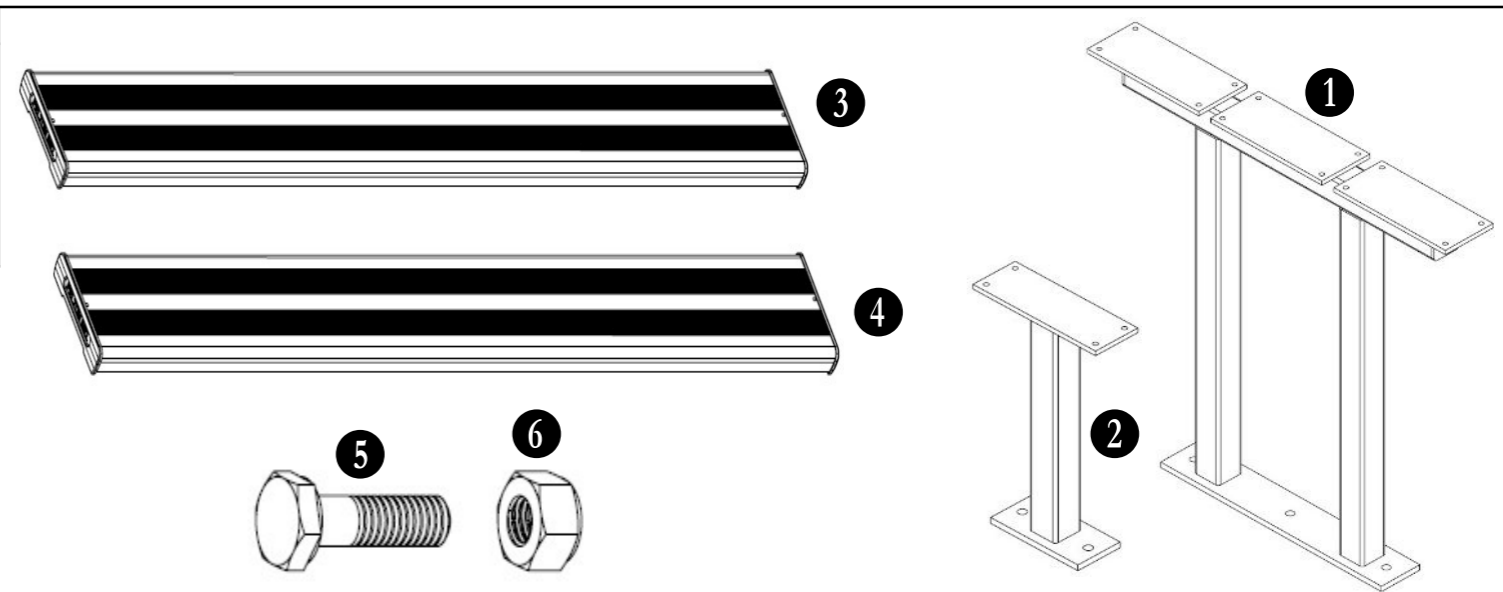

Please note that the table planks 3 and seat planks 4 have the same length (1800 mm), but they are different in the distance between holes Ø8 attaching those planks to the frames. Sort out table and seat planks to avoid taking the wrong plank during assembly.

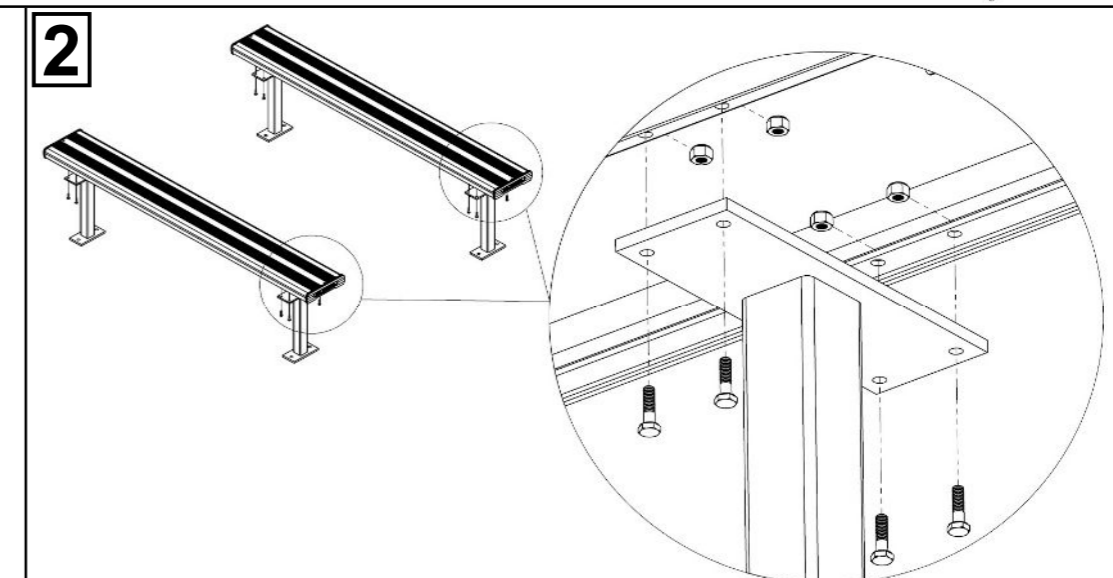

Attach two seat planks 4 to four seat frames 2 by using bolts 5 and nuts 6 to create two seat assemblies as illustrated.

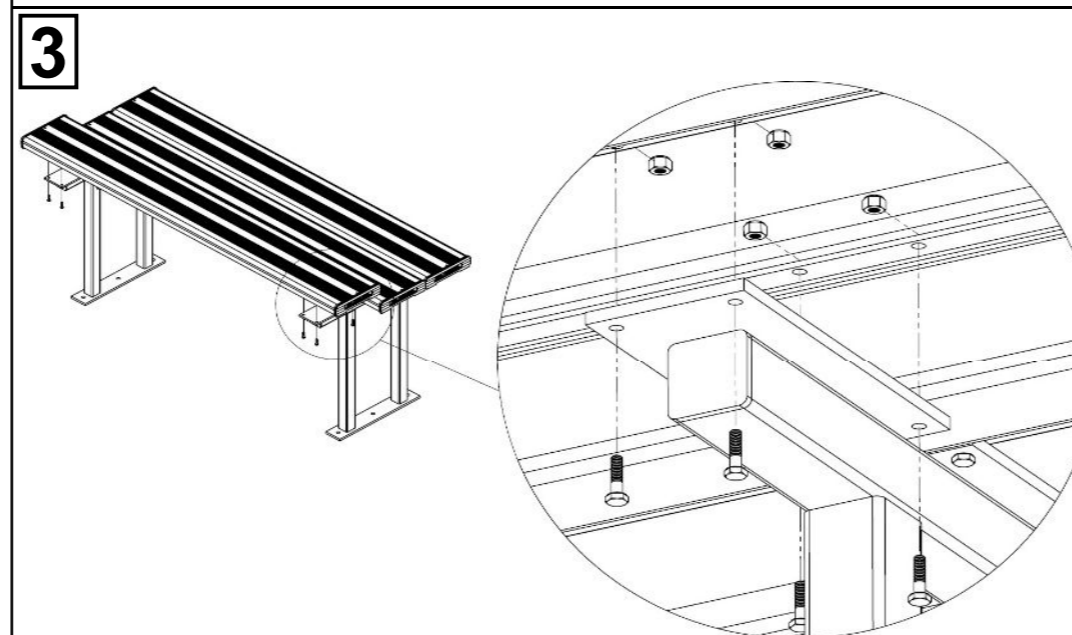

Attach three table planks 3 to two table frames 1 by using bolts 5 and nuts 6 to create the table assembly as illustrated.

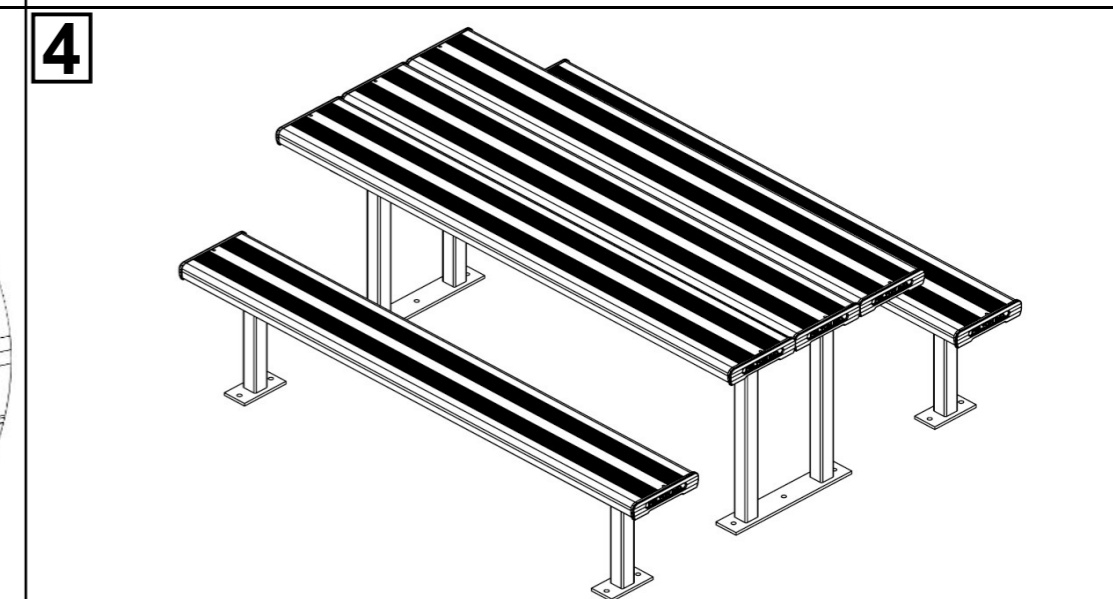

Tighten all hexagonal head bolts with spanners and appropriate tools. Then attach the table and seat assemblies to the ground by using M12 dyna-bolts on each ground fixing plate. Refer to the product's "SPECIFICATION DRAWING" for relative dimensions and technical recommendation.