

ASSEMBLY INSTRUCTION

Thank You

FOR CHOOSING FELTON INDUSTRIES

ADVANCED PARK SETTING
WITH BACK REST
[Code No: FELAPSBR]



WARNING: This assembly required two or more people as lifting is involved. Please ensure bolts and nuts are only finger-tightened throughout assembly for flexibility in lining up components. Bolt and nuts should be securely tightened in place when instructed to do so. Please check all components are included before proceeding with the assembly

ITEM	DESCRIPTION	Qty
1	FELAPSBR_MAIN FRAME	2
2	FELAPSBR_TABLE PLANK L1800	3
3	FELAPSBR_SEAT PLANK L1800	2
4	FELAPSBR_BACKREST PLANK L1800	2
5	AS-NZS 2465 Bolt - 1/4" x 1"	48
6	AS-NZS NYLON Nut - 1/4"	48

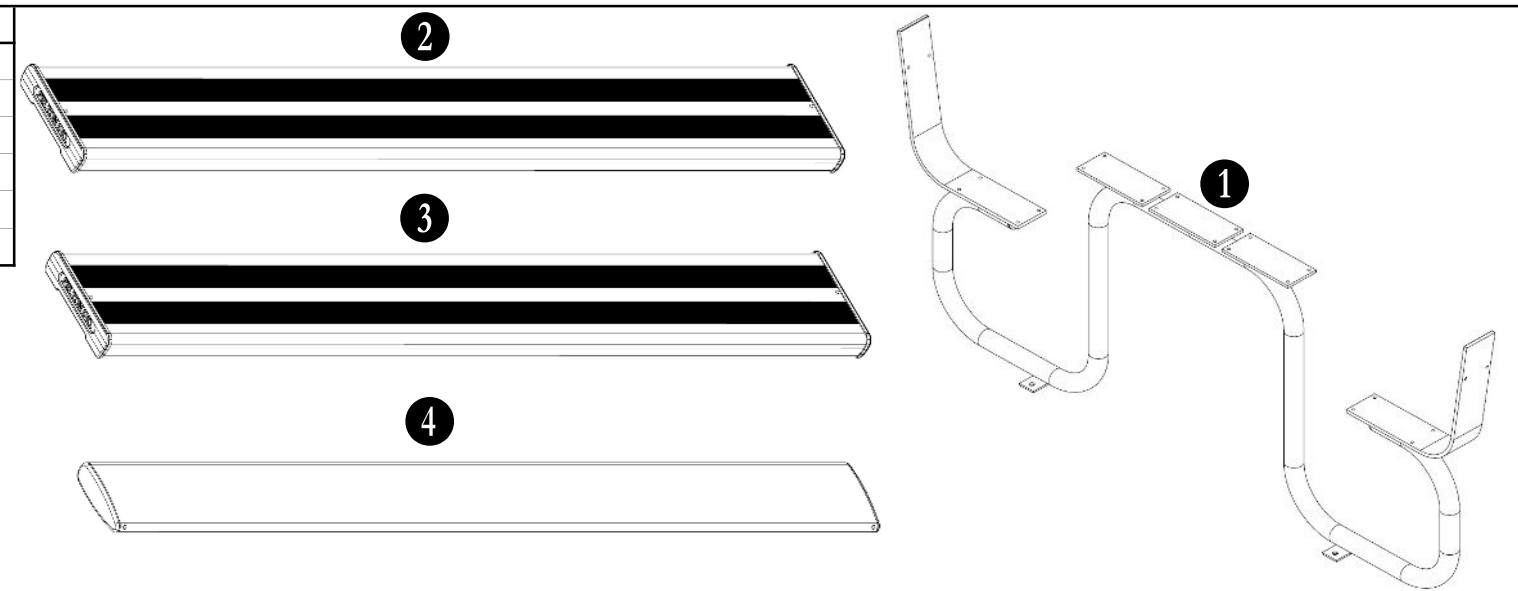

1

Attach three table planks **2** to two base frames **1** by using bolts **5** and nuts **6** as illustrated. **Note that all fixing lugs on base frames **1** face inwards.**

2

Attach two seat planks **3** (with notch cut beneath) onto fixing plates by using bolts **5** and nuts **6** as illustrated.

3

Install two backrest planks **4** onto frame fixing plates as illustrated. Fasten the seat planks **3** with hexagonal bolts **5** and nuts **6**. Ensure the fixing plates are installed in the right place on backrest.

4

Tighten all hexagonal head bolts with spanners and appropriate tools. Then attach the whole assembly to the ground by using M12 dyna-bolts preferably, on each frame lug.

"This product has been manufactured in Australia to the highest quality standard, guaranteeing proven quality, durability and low maintenance"



1800 22 00 55

1800 05 91 58

sales@felton.net.au

www.felton.net.au



Felton Industries Pty Ltd | ABN: 17 130 687 240