

ASSEMBLY INSTRUCTION

Thank You

FOR CHOOSING FELTON INDUSTRIES

DOUBLE BENCH SHELTER
[Code No:FELDBSH]



WARNING: This assembly required two or more people as lifting is involved. Please ensure bolts and nuts are only finger-tightened throughout assembly for flexibility in lining up components. Bolt and nuts should be securely tightened in place when instructed to do so. Please check all components are included before proceeding with the assembly

ITEM	DESCRIPTION	Qty
1	FELDBSH_BASE FRAME	2
2	FELDBSH_SEAT FRAME	1
3	FELDBSH_SEAT PLANK L2020	2
4	FELDBSH_ROOF	1
5	AS-NZS 2465 Bolt - 1/2" x 4.5"	4
6	AS-NZS 2465 Bolt - 1/2" x 3.5"	2
7	AS-FLAT Washer - 1/2"	20
8	AS-NZS NYLON Nut - 1/2"	10
9	AS-NZS 2465 Bolt - 1/4" x 1"	12
10	AS-NZS NYLON Nut - 1/4"	12
11	AS-NZS 2465 Bolt - 1/2" x 1.5"	4

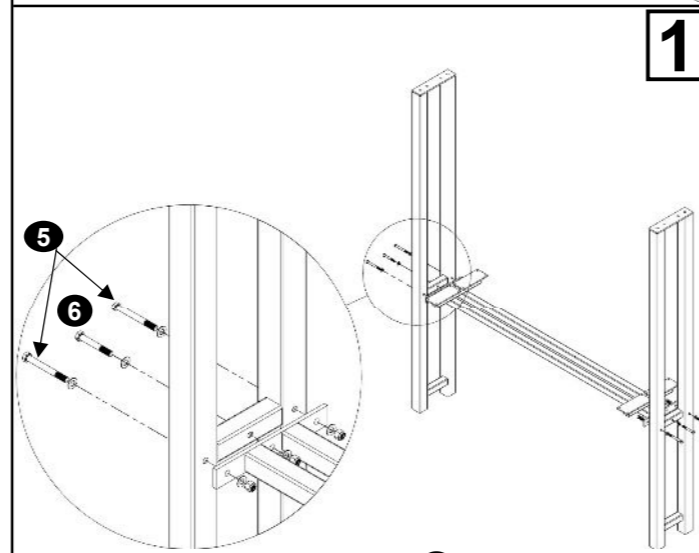
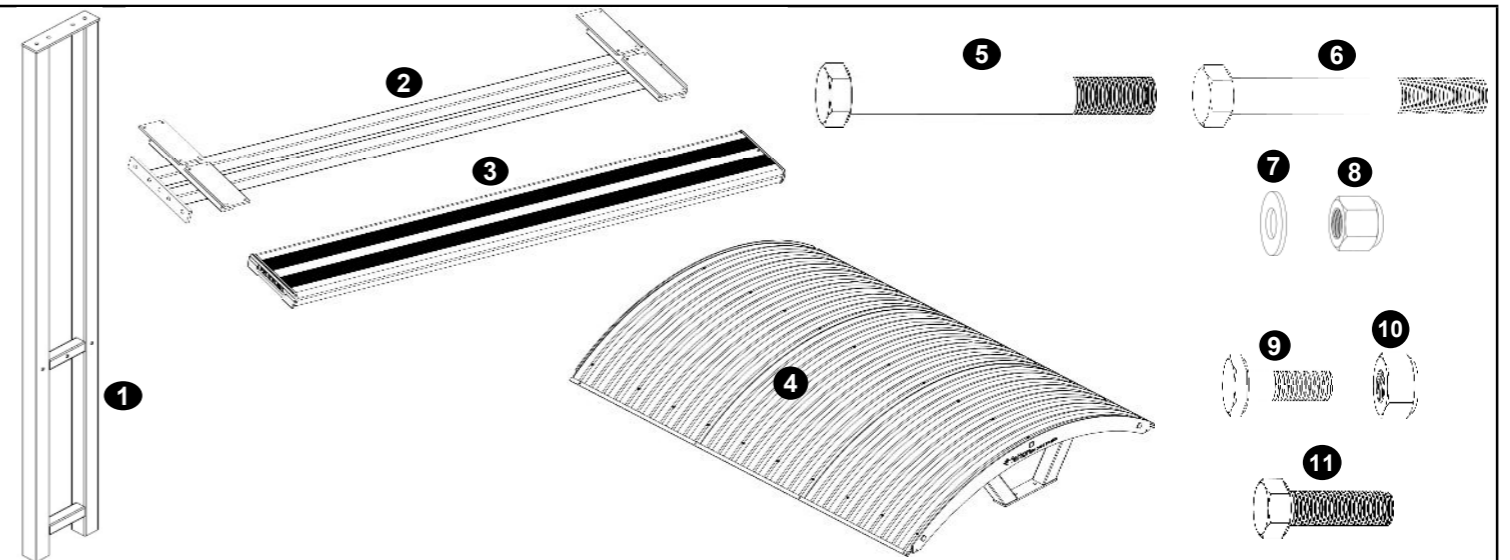

Attach the two base frames **1** to the seat frame **2** by using bolts **5**, bolts **6**, washes **7** and nuts **8**

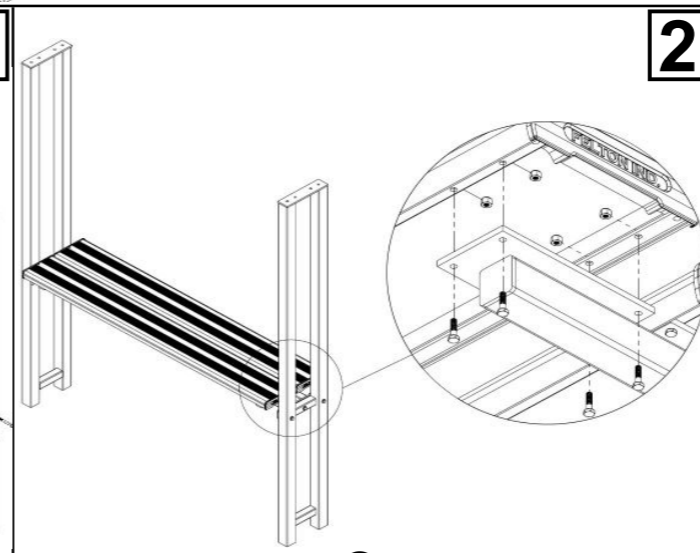

Install two seat planks **3** onto frame fixing plates as illustrated. Fasten the seat planks **3** with hexagonal bolts **9** and nuts **10**

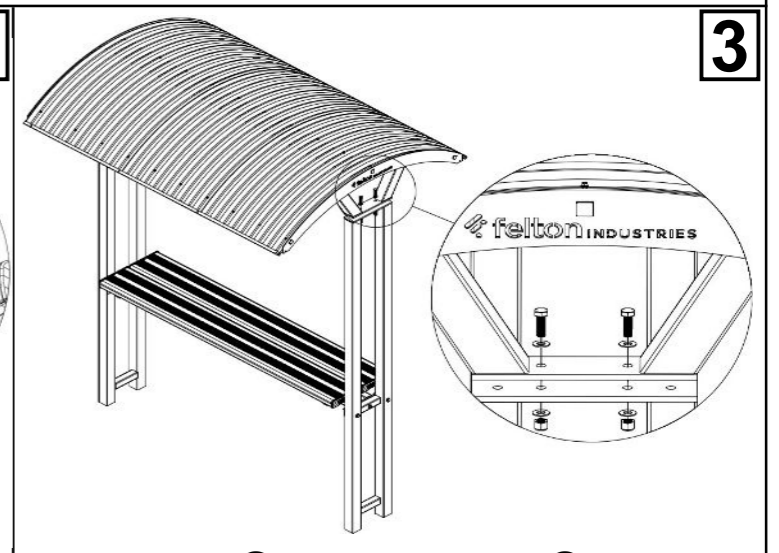

Attach the roof **4** to the base frames **1**. Fasten the roof **4** with hexagonal bolts **11**, washes **7** and nuts **8**

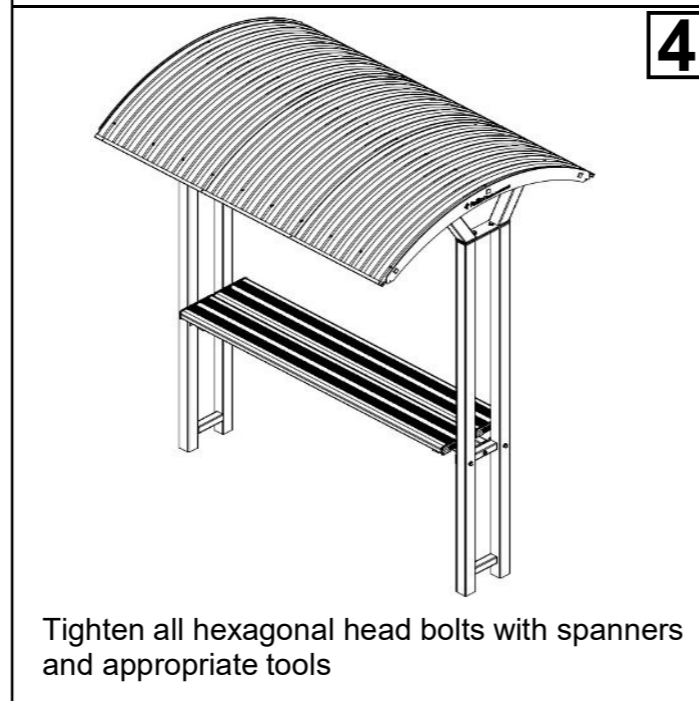

Tighten all hexagonal head bolts with spanners and appropriate tools

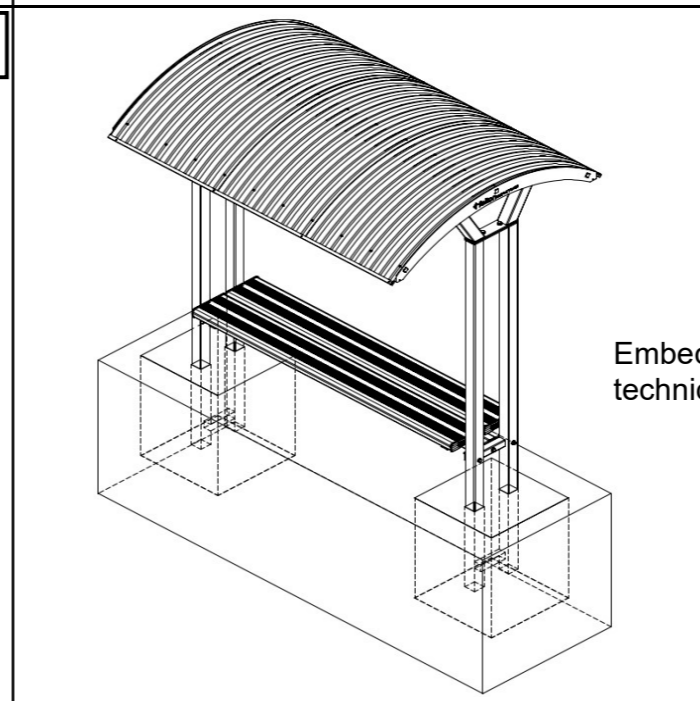

Embed the whole assembly to the concrete base as per technical recommendation in "SPECIFICATION DRAWING"

"This product has been manufactured in Australia to the highest quality standard, guaranteeing proven quality, durability and low maintenance"



1800 22 00 55

1800 05 91 58

sales@felton.net.au

www.felton.net.au

felton
INDUSTRIES

Felton Industries Pty Ltd | ABN: 17 130 687 240