

# ASSEMBLY INSTRUCTION

*Thank You*

FOR CHOOSING FELTON INDUSTRIES

**STACKABLE BENCH SEAT 2mtr**  
[Code No: FELFSS2]



"This product has been manufactured in Australia to the highest quality standard, guaranteeing proven quality, durability and low maintenance"



☎ 1800 22 00 55

🖨 1800 05 91 58

✉ sales@felton.net.au

🌐 www.felton.net.au



Felton Industries Pty Ltd | ABN: 17 130 687 240



**WARNING:** This assembly required two or more people as lifting is involved. **Please ensure bolts and nuts are only finger-tightened throughout assembly for flexibility in lining up components.** Bolt and nuts should be securely tightened in place when instructed to do so. Please check all components are included before proceeding with the assembly

ITEM	DESCRIPTION	Qty
1	FELFSSLS_FREE STANDING LEG SUPPORT	2
2	FELFSS2_SEAT PLANK L2000	1
3	AS-NZS 2465 Bolt - 1/4" x 1"	8
4	AS-NZS NYLON Nut - 1/4"	8

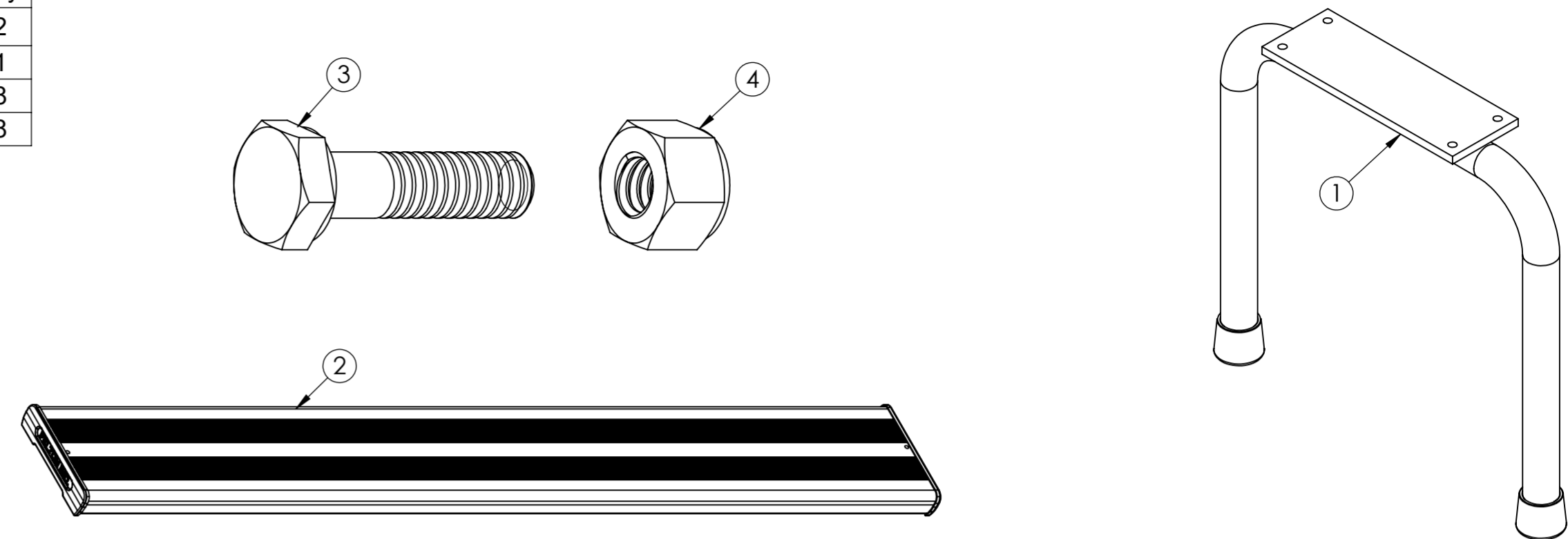

**1**

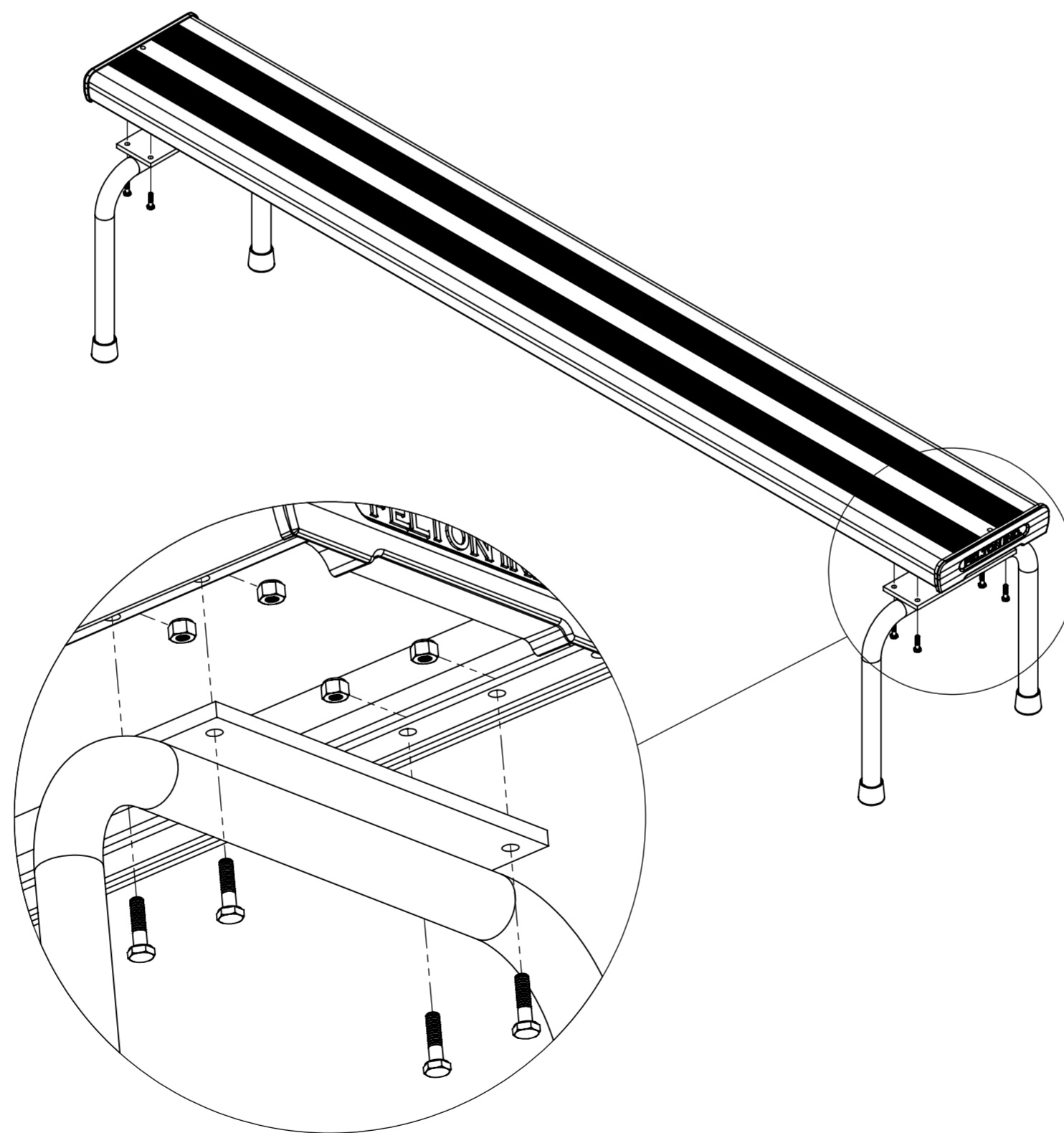

Attach the seat plank (2) to two leg supports (1) by using bolts (3) and nuts (4) as illustrated.

**2**

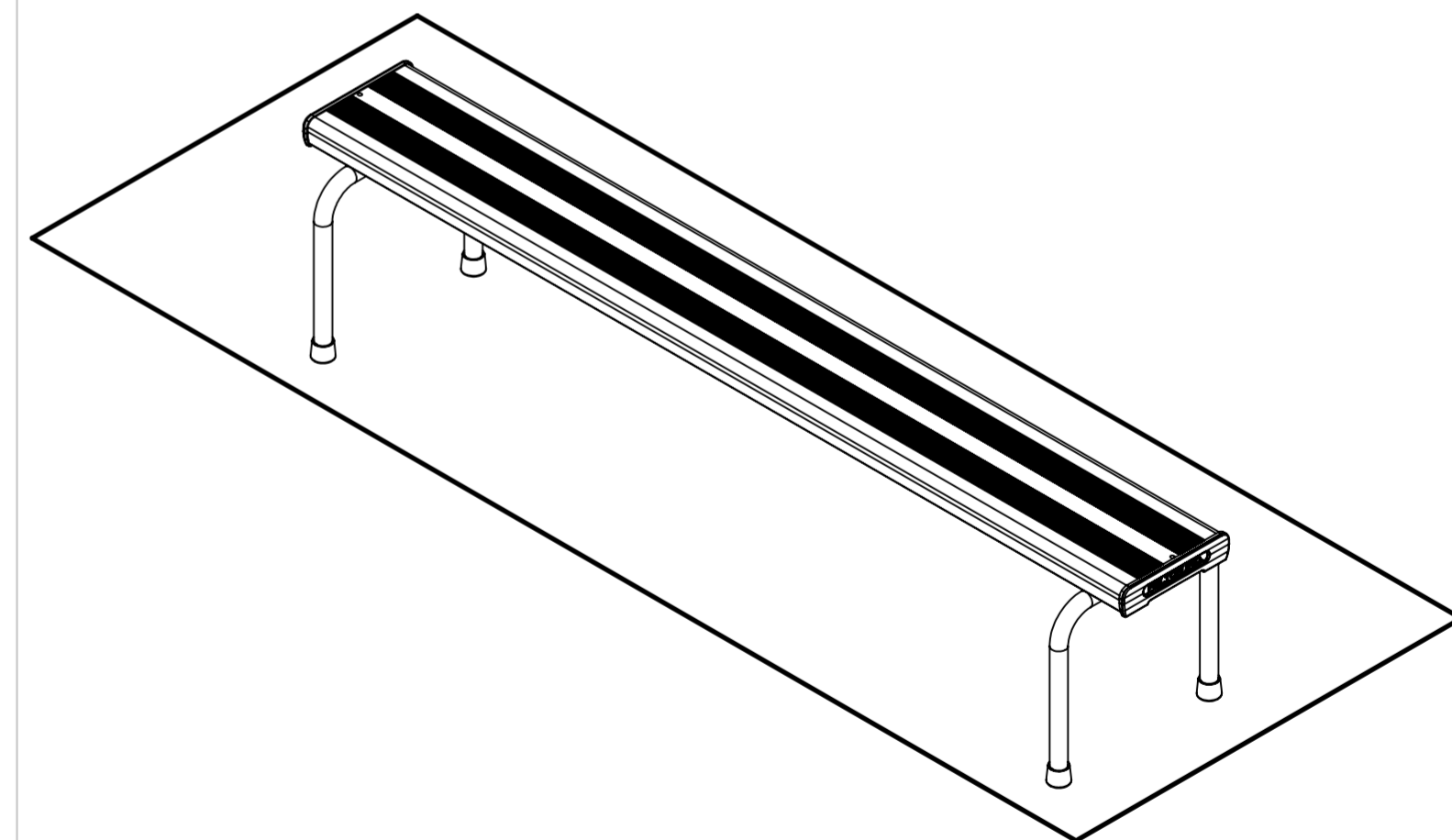

Tighten all hexagonal head bolts with spanners and appropriate tools. Then attach the whole assembly to the ground by using M12 dyna-bolts preferably, on each frame lug.