

ASSEMBLY INSTRUCTION

Thank You

FOR CHOOSING FELTON INDUSTRIES

DOUBLE PLANK SEATING 2 mtr
[Code No: FELGCR12]



"This product has been manufactured in Australia to the highest quality standard, guaranteeing proven quality, durability and low maintenance"



☎ 1800 22 00 55

🖨 1800 05 91 58

✉ sales@felton.net.au

🌐 www.felton.net.au



Felton Industries Pty Ltd | ABN: 17 130 687 240



WARNING: This assembly required two or more people as lifting is involved. **Please ensure bolts and nuts are only finger-tightened throughout assembly for flexibility in lining up components.** Bolt and nuts should be securely tightened in place when instructed to do so. Please check all components are included before proceeding with the assembly

| ITEM | DESCRIPTION | Qty |
|------|------------------------------|-----|
| 1 | FELGCR_BASE FRAME | 2 |
| 2 | FELGCR12_PLANK L2000 | 2 |
| 3 | AS-NZS 2465 Bolt - 1/4" x 1" | 16 |
| 4 | AS-NZS NYLON Nut - 1/4" | 16 |

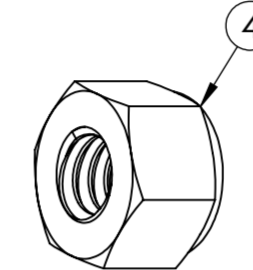
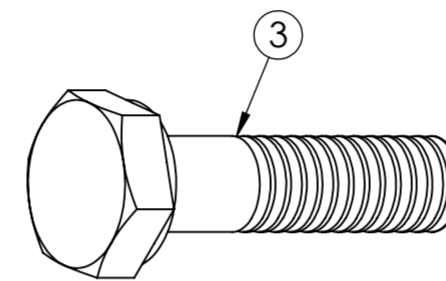
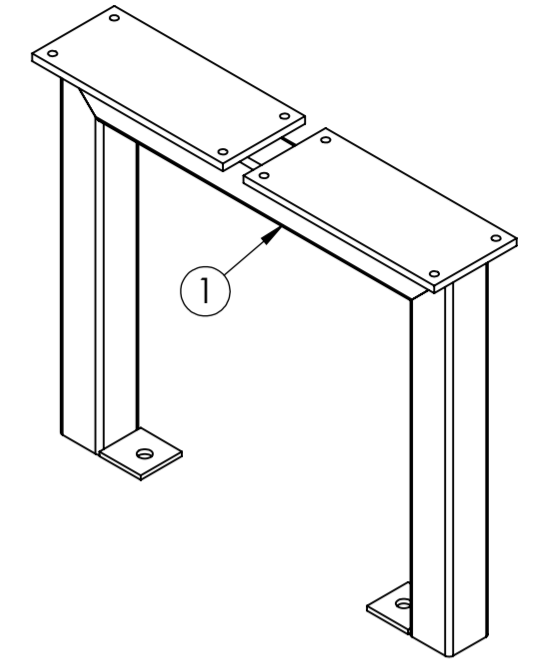
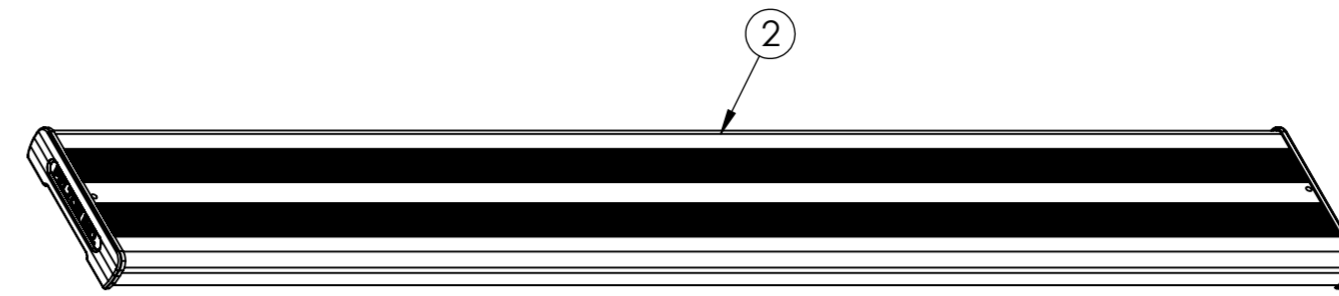

1

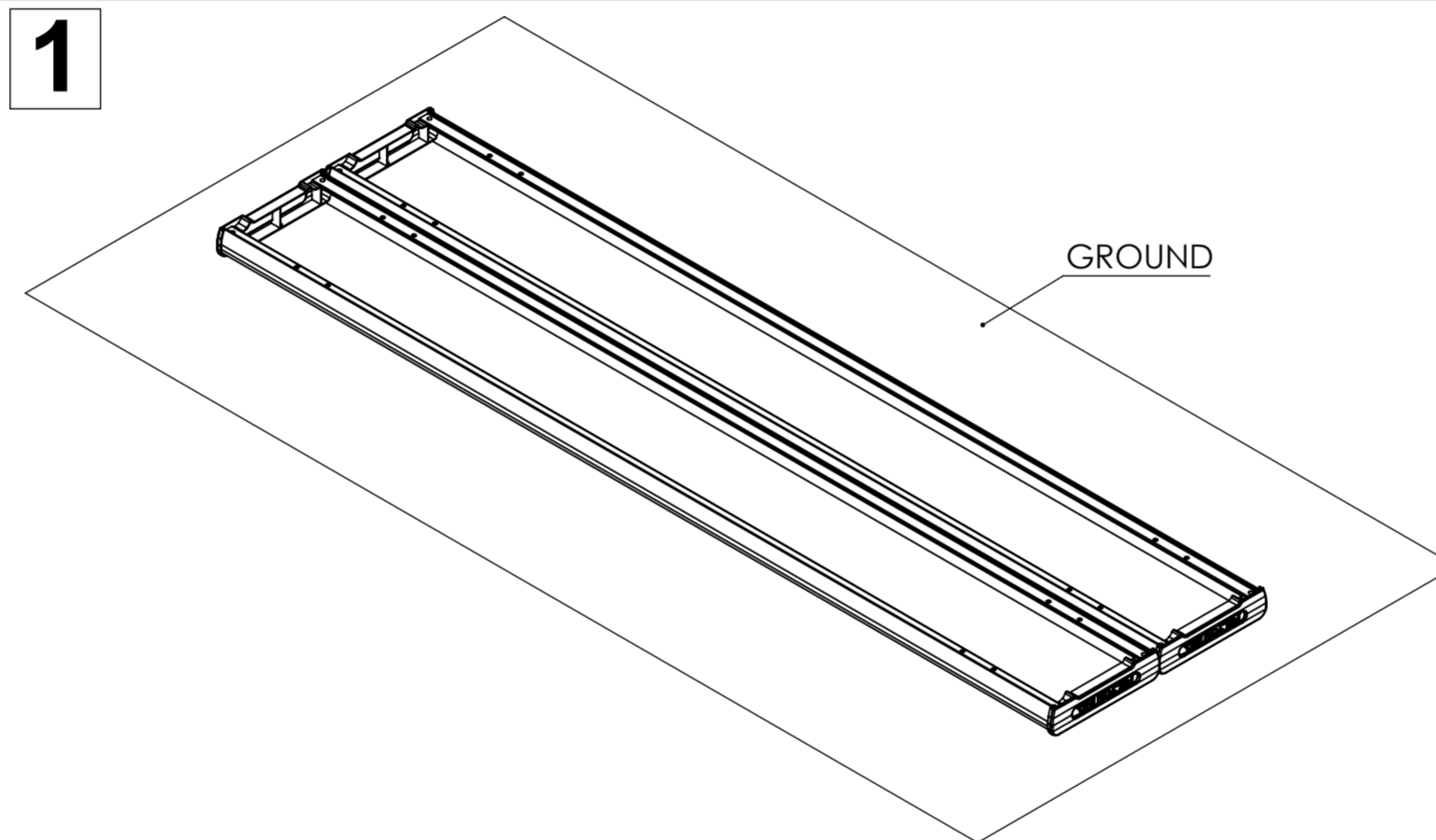

Place two planks (2) upside down and close together on the flat ground as illustrated.

2

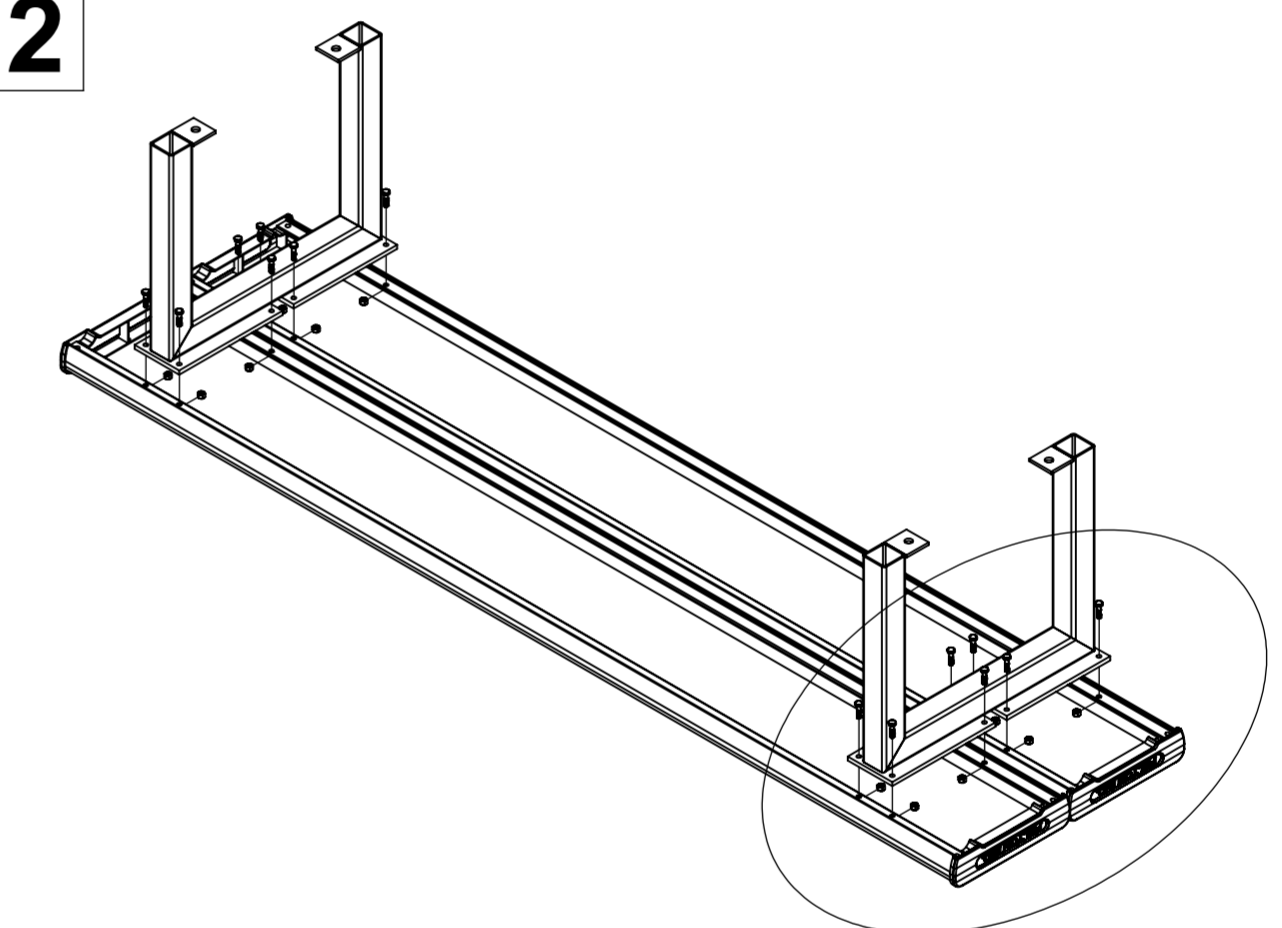

3

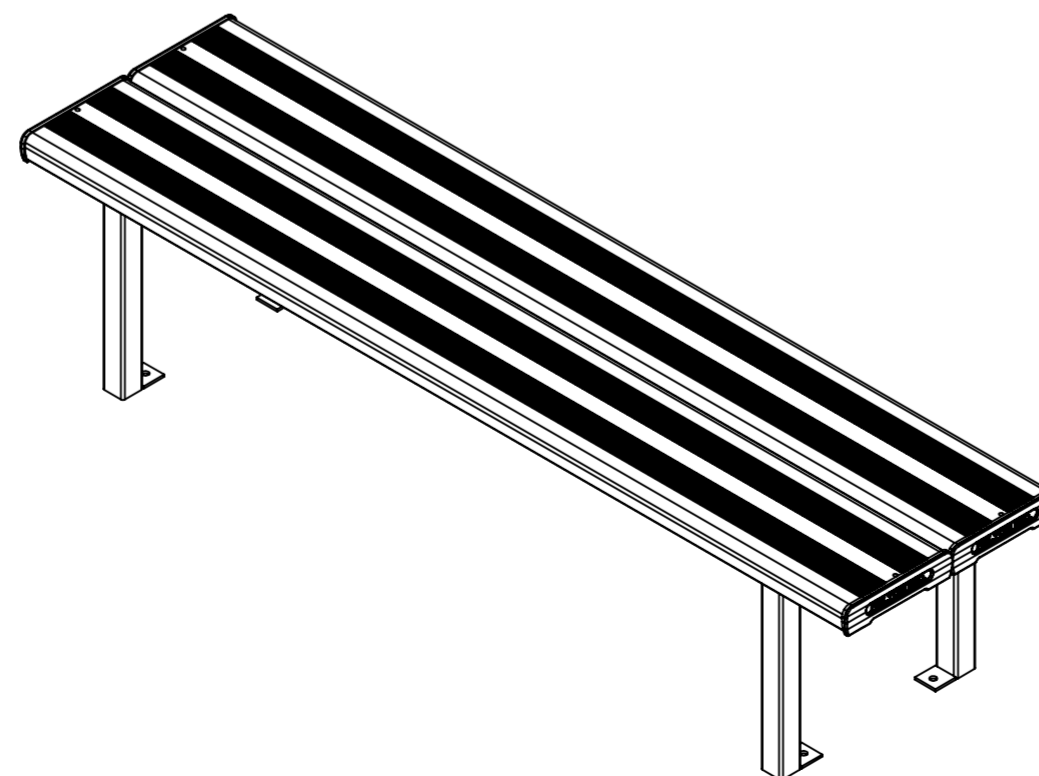

Tighten all hexagonal head bolts with spanners and appropriate tools. Then attach the whole assembly to the ground by using M12 dyna-bolts preferably, on each frame lug.

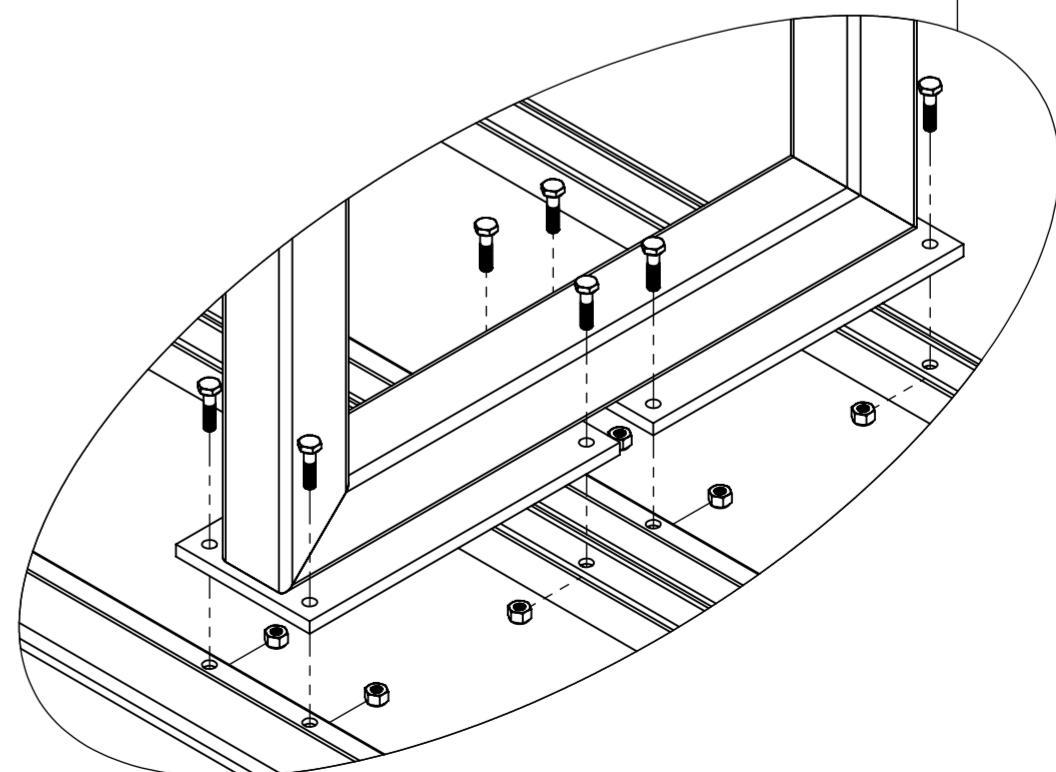

Attach two base frames (1) to two planks (2) in step 1 by using bolts (3) and nuts (4) as illustrated.