

# ASSEMBLY INSTRUCTION

*Thank You*

FOR CHOOSING FELTON INDUSTRIES

**DOUBLE PLANK SEATING 3 mtr**  
[Code No: FELGCR13]



"This product has been manufactured in Australia to the highest quality standard, guaranteeing proven quality, durability and low maintenance"



☎ 1800 22 00 55

📠 1800 05 91 58

✉ sales@felton.net.au

🌐 www.felton.net.au



Felton Industries Pty Ltd | ABN: 17 130 687 240



**WARNING:** This assembly required two or more people as lifting is involved. **Please ensure bolts and nuts are only finger-tightened throughout assembly for flexibility in lining up components.** Bolt and nuts should be securely tightened in place when instructed to do so. Please check all components are included before proceeding with the assembly

ITEM	DESCRIPTION	Qty
1	FELGCR_BASE FRAME	3
2	FELGCR13_PLANK L3000	2
3	AS-NZS 2465 Bolt - 1/4" x 1"	24
4	AS-NZS NYLON Nut - 1/4"	24

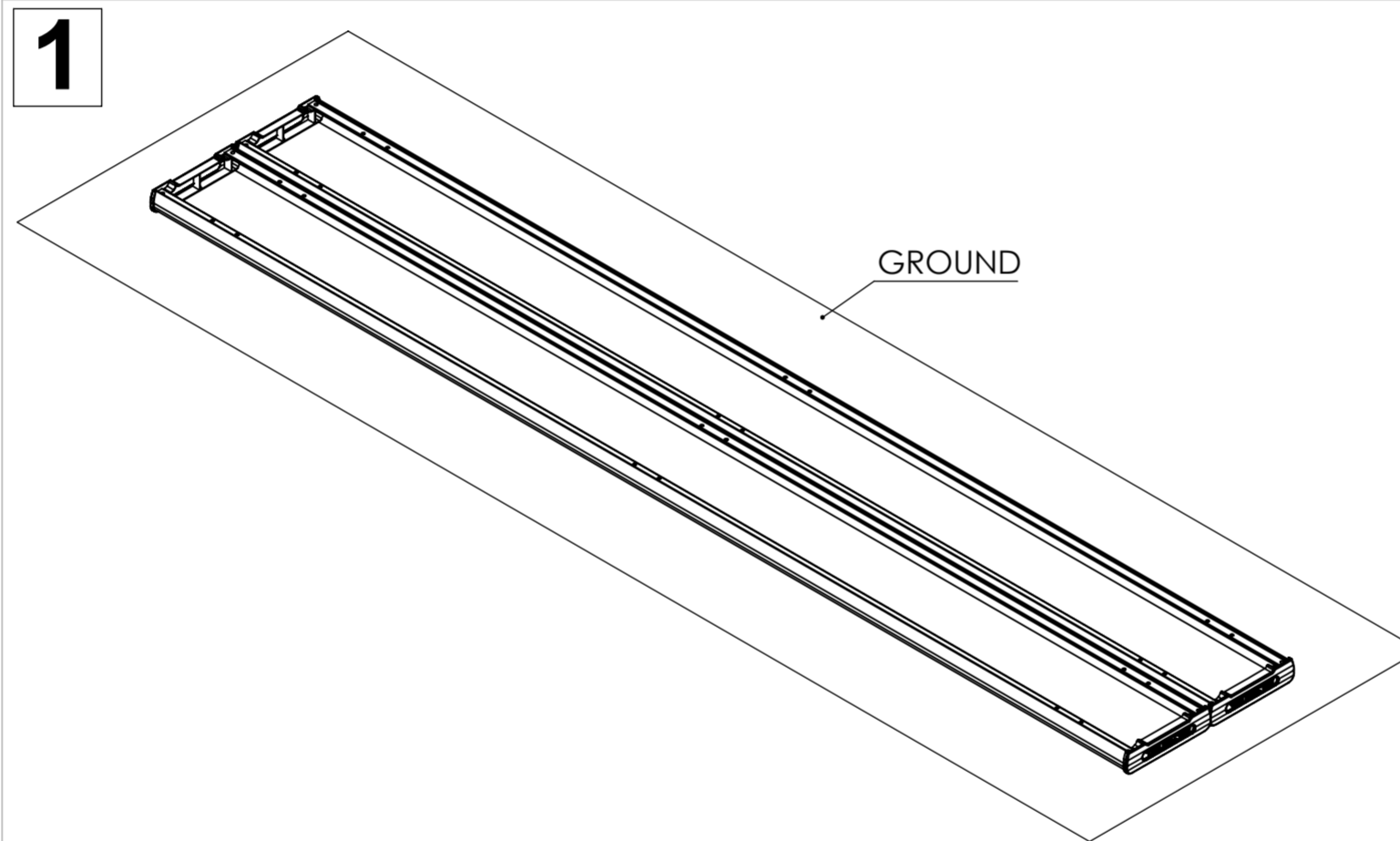
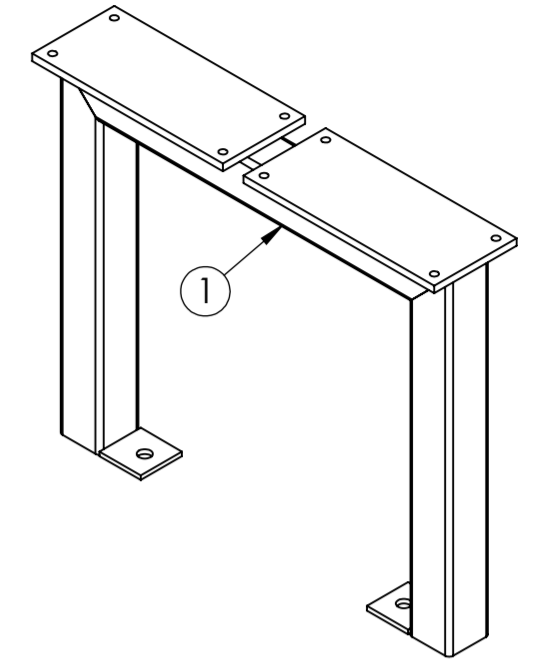
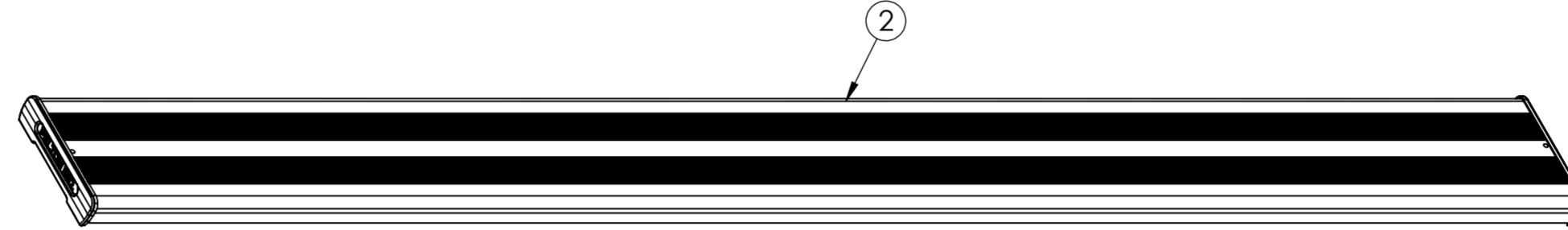
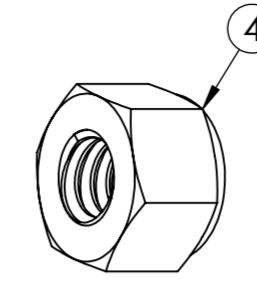
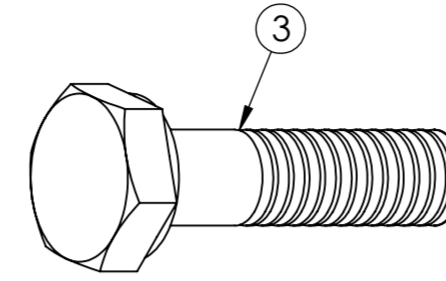

Place two planks (2) upside down and close together on the flat ground as illustrated.

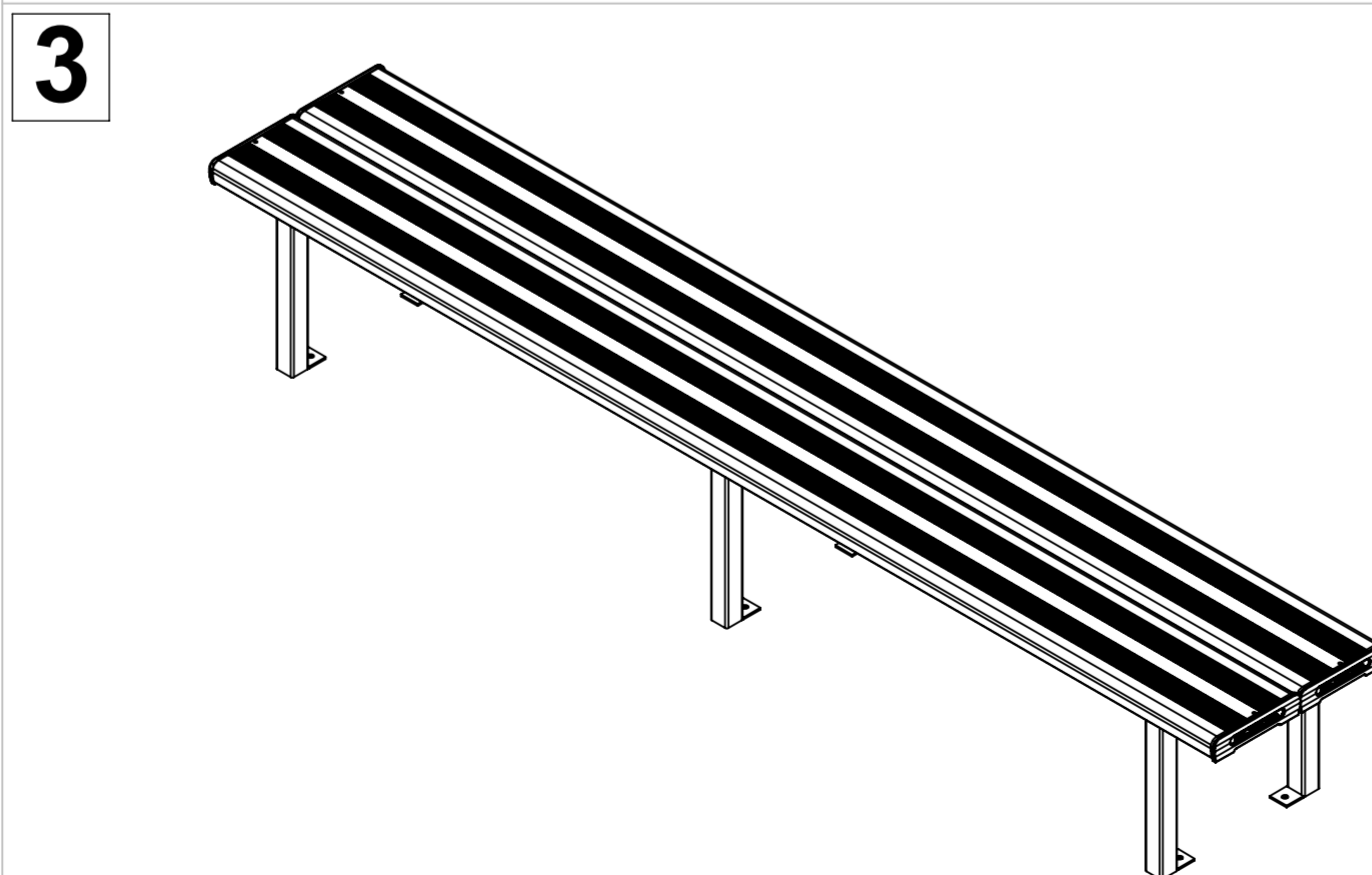
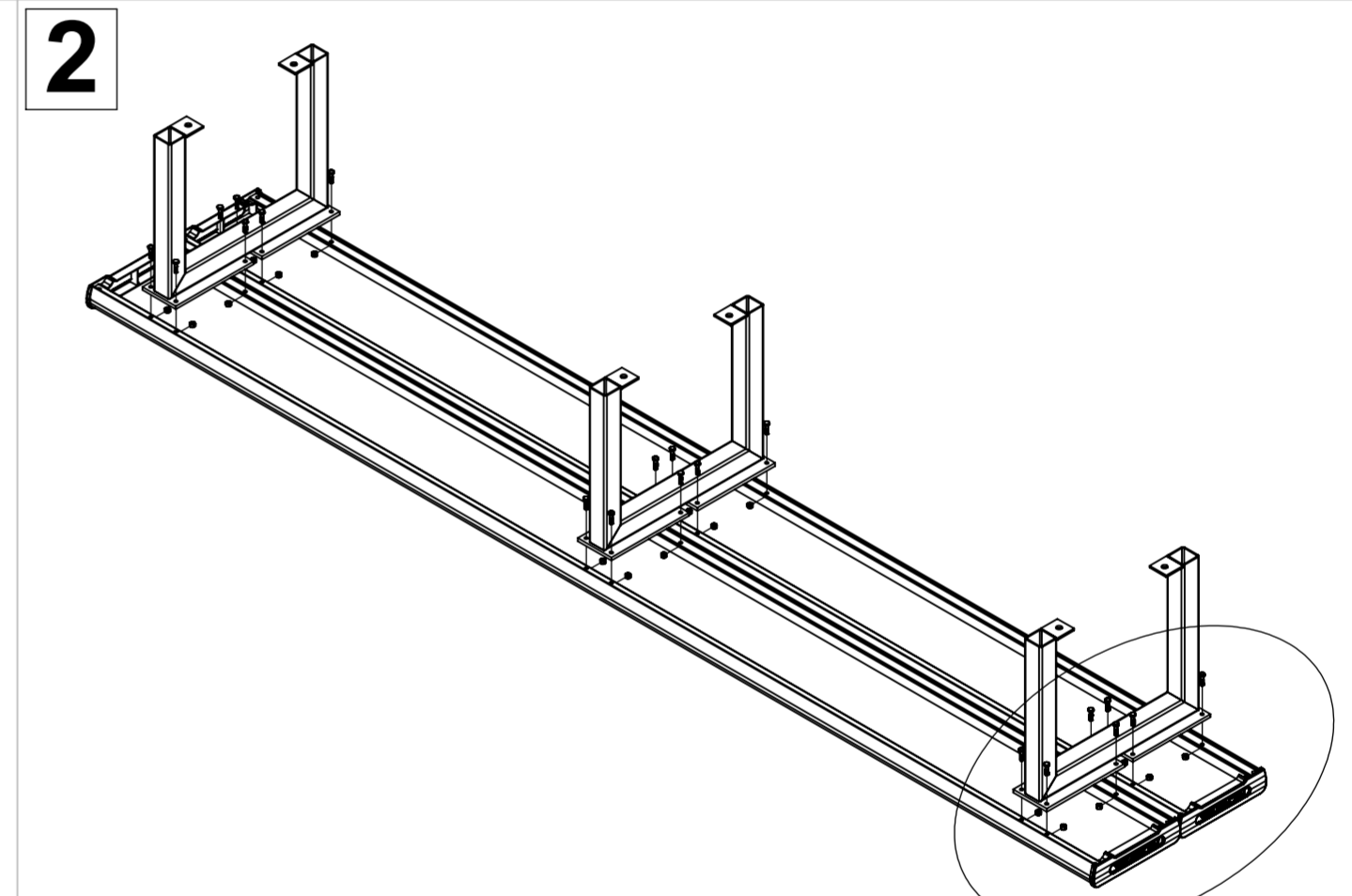

Tighten all hexagonal head bolts with spanners and appropriate tools. Then attach the whole assembly to the ground by using M12 dyna-bolts preferably, on each frame lug.

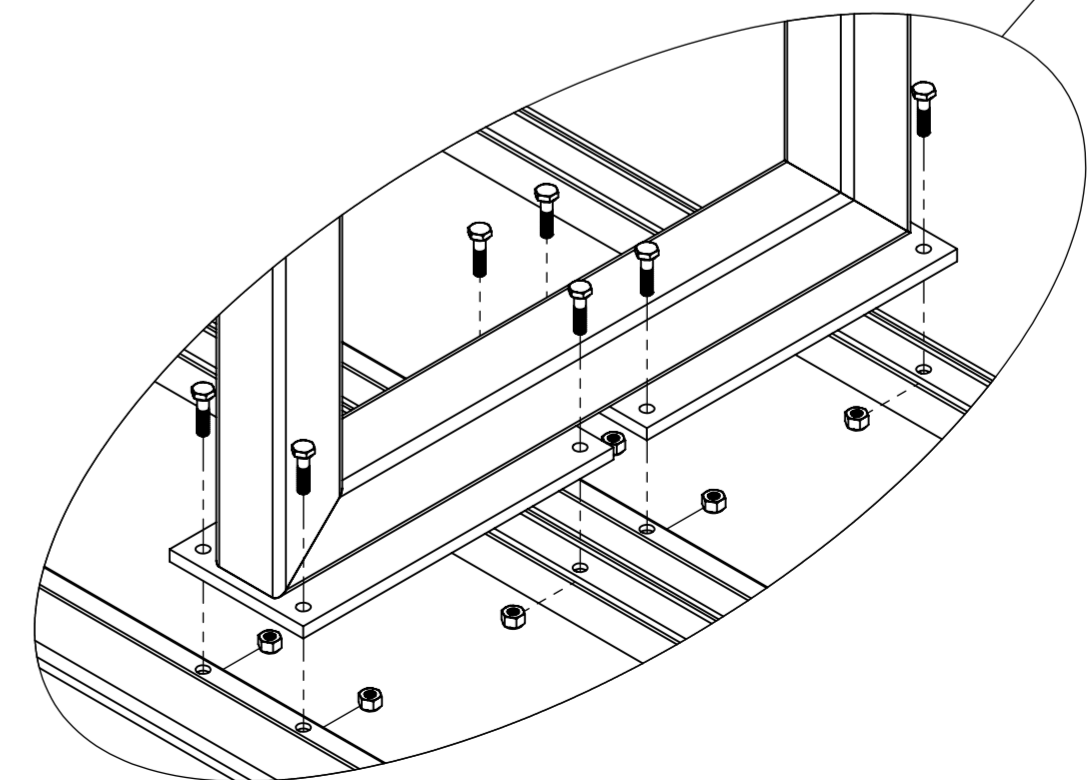

Attach three base frames (1) to two planks (2) in step 1 by using bolts (3) and nuts (4) as illustrated.