

ASSEMBLY INSTRUCTION

Thank You

FOR CHOOSING FELTON INDUSTRIES

**IN-GROUND BENCH SEAT
WITH BACKREST 4mtr
[Code No: FELIGB4]**



"This product has been manufactured in Australia to the highest quality standard, guaranteeing proven quality, durability and low maintenance"



☎ 1800 22 00 55

🖨 1800 05 91 58

✉ sales@felton.net.au

🌐 www.felton.net.au



Felton Industries Pty Ltd | ABN: 17 130 687 240



WARNING: This assembly required two or more people as lifting is involved. **Please ensure bolts and nuts are only finger-tightened throughout assembly for flexibility in lining up components.** Bolt and nuts should be securely tightened in place when instructed to do so. Please check all components are included before proceeding with the assembly

ITEM	DESCRIPTION	Qty
1	FELIGLS_IN-GROUND BACKREST LEG SUPPORT	3
2	FELIGB4_SEAT PLANK L4000	1
3	FELIGB4_BACKREST PLANK L4000	1
4	AS-NZS 2465 Bolt - 1/4" x 1"	18
5	AS-NZS NYLON Nut - 1/4"	18

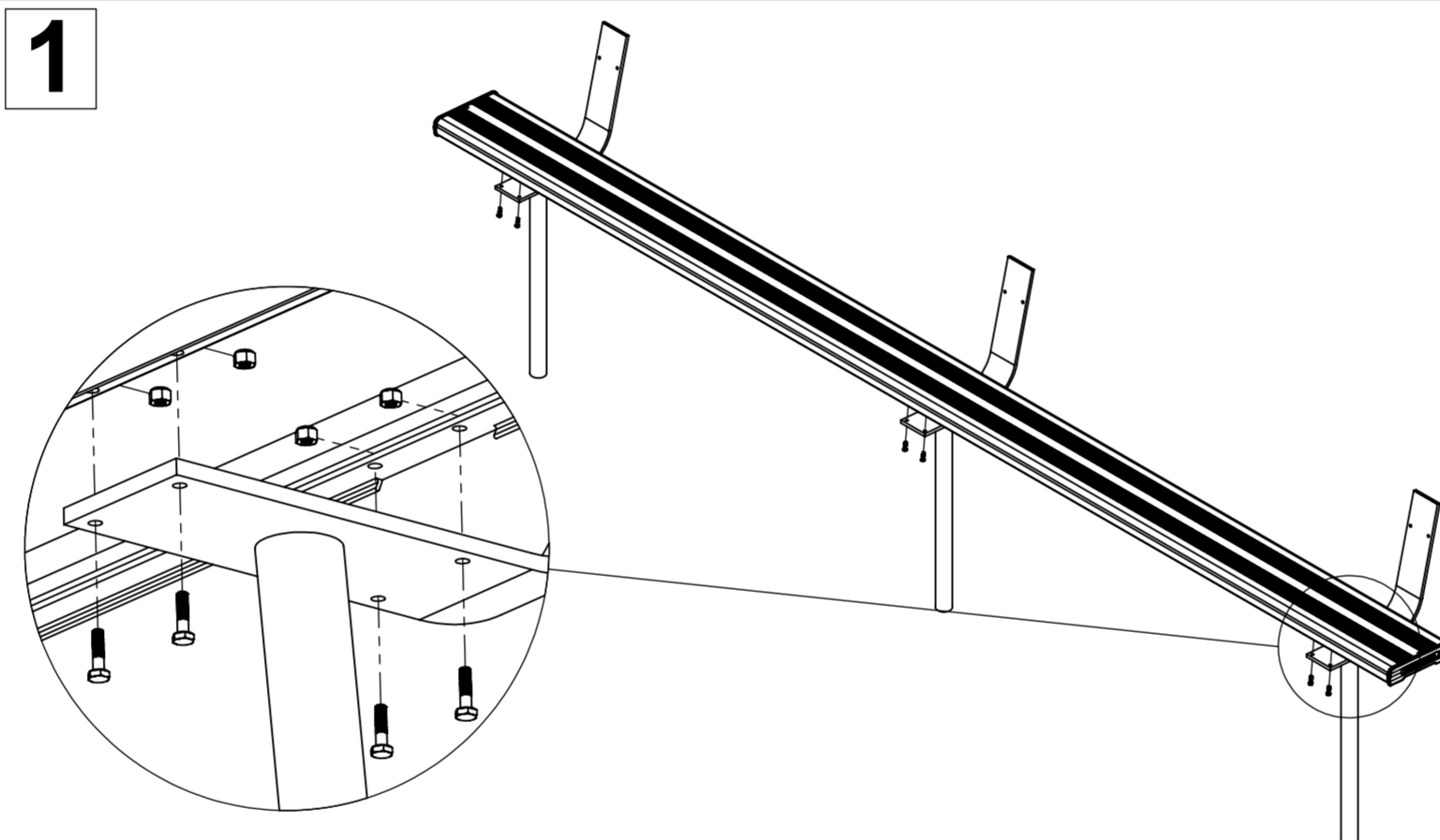
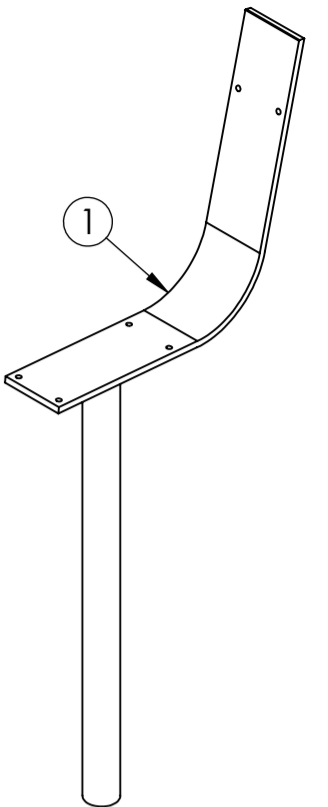
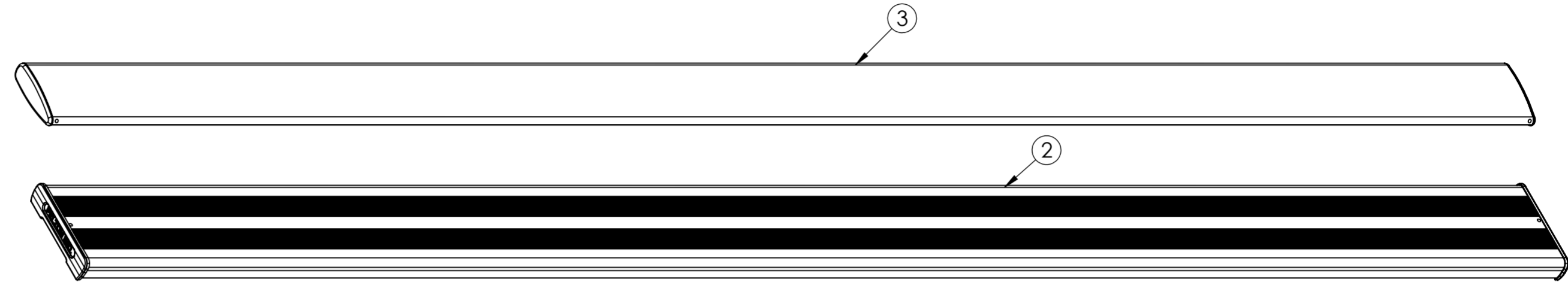
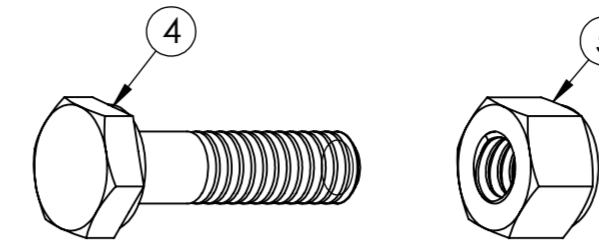

Attach the seat plank (2) to three leg supports (1) by using bolts (4) and nuts (5) as illustrated.

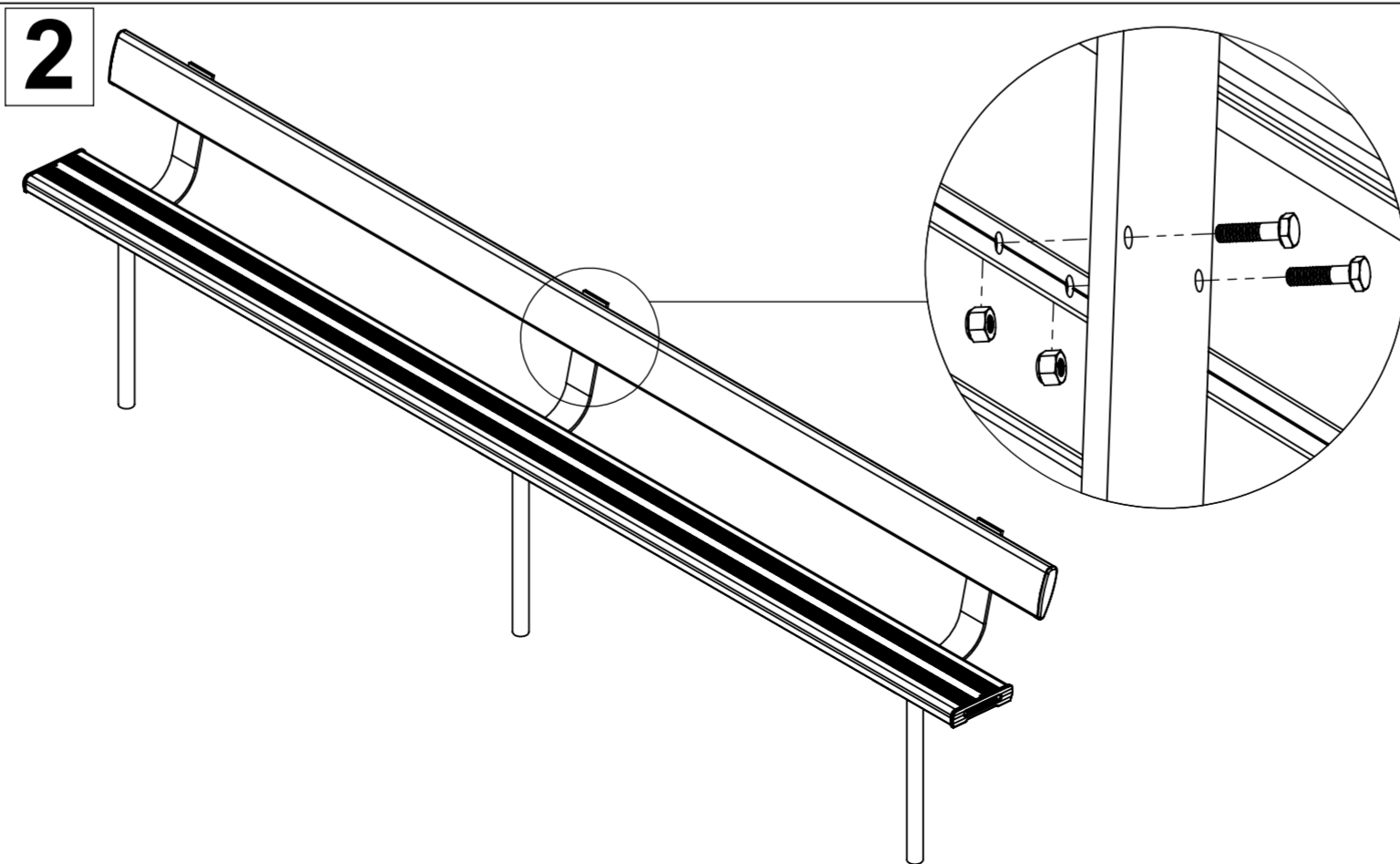

Attach the backrest plank (3) to the assembly in step 1 by using bolts (4) and nuts (5) as illustrated.

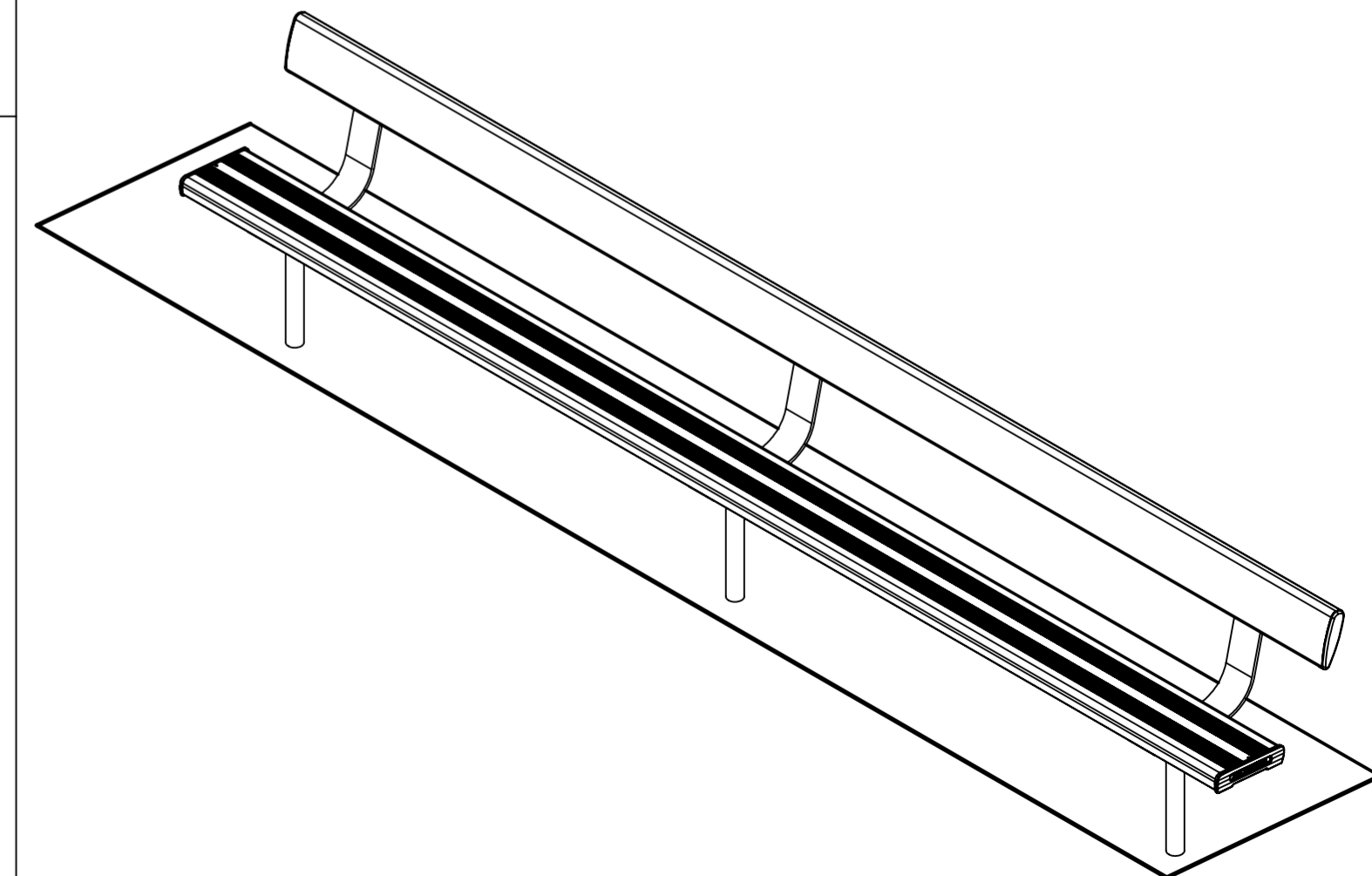
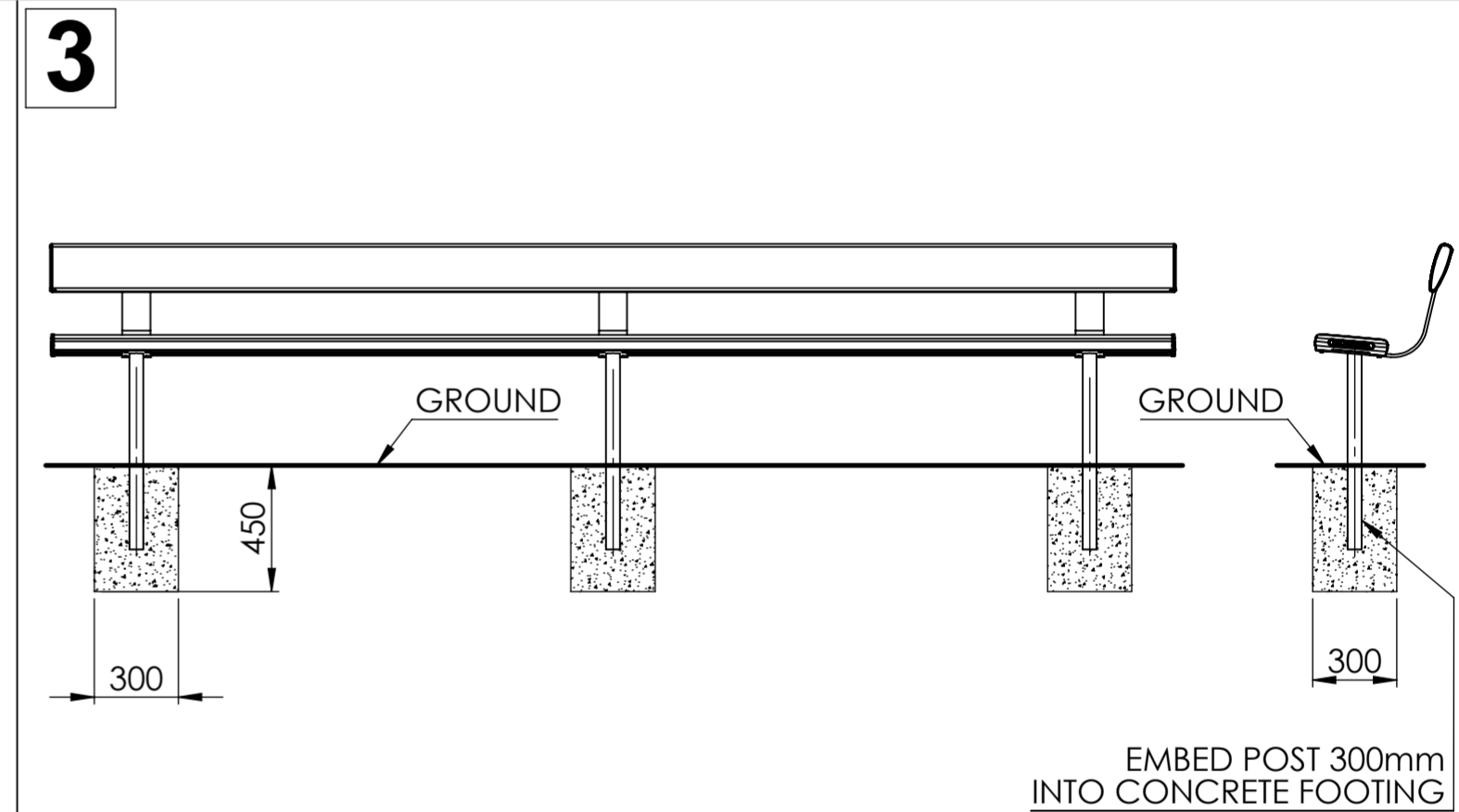

Tighten all hexagonal head bolts with spanners and appropriate tools. Then embed the structure min.300mm to the ground. Refer to "specification drawing" for detailed engineering requirement.