

ASSEMBLY INSTRUCTION

Thank You

FOR CHOOSING FELTON INDUSTRIES

INTERACTIVE WHEELCHAIR SETTING
[Code No: FELIWS]



"This product has been manufactured in Australia to the highest quality standard, guaranteeing proven quality, durability and low maintenance"



1800 22 00 55

1800 05 91 58

sales@felton.net.au

www.felton.net.au



Felton Industries Pty Ltd | ABN: 17 130 687 240



WARNING: This assembly required two or more people as lifting is involved. Please ensure bolts and nuts are only finger-tightened throughout assembly for flexibility in lining up components. Bolt and nuts should be securely tightened in place when instructed to do so. Please check all components are included before proceeding with the assembly

ITEM	DESCRIPTION	Qty
1	FELIWS_CENTRAL FRAME	1
2	FELIWS_SIDE FRAME	2
3	FELIWS_TABLE PLANK L2400	3
4	FELIWS_SEAT PLANK L1440	2
5	AS-NZS 2465 Bolt - 1/4" x 1"	52
6	AS-NZS NYLON Nut - 1/4"	52

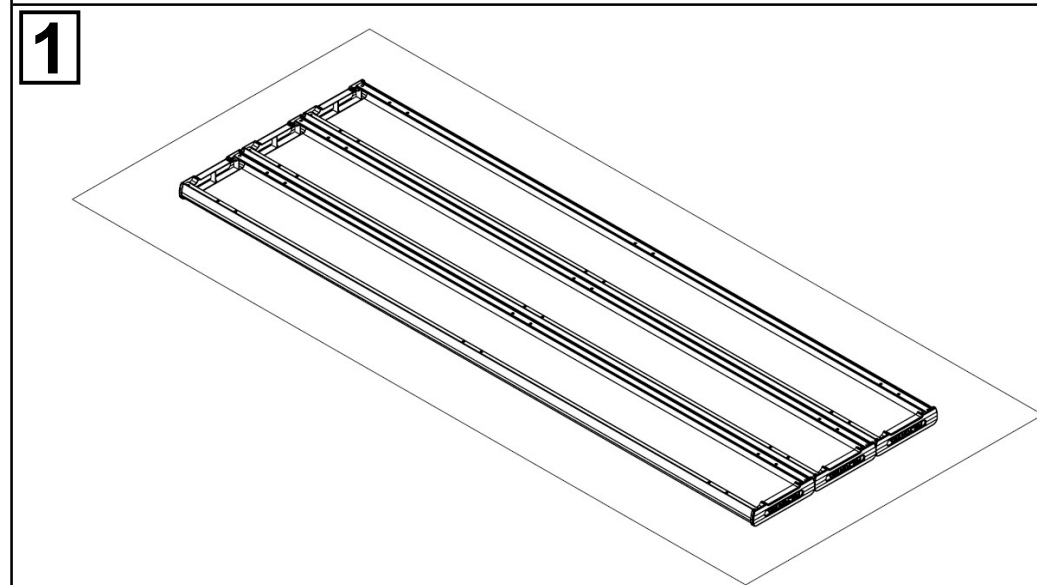
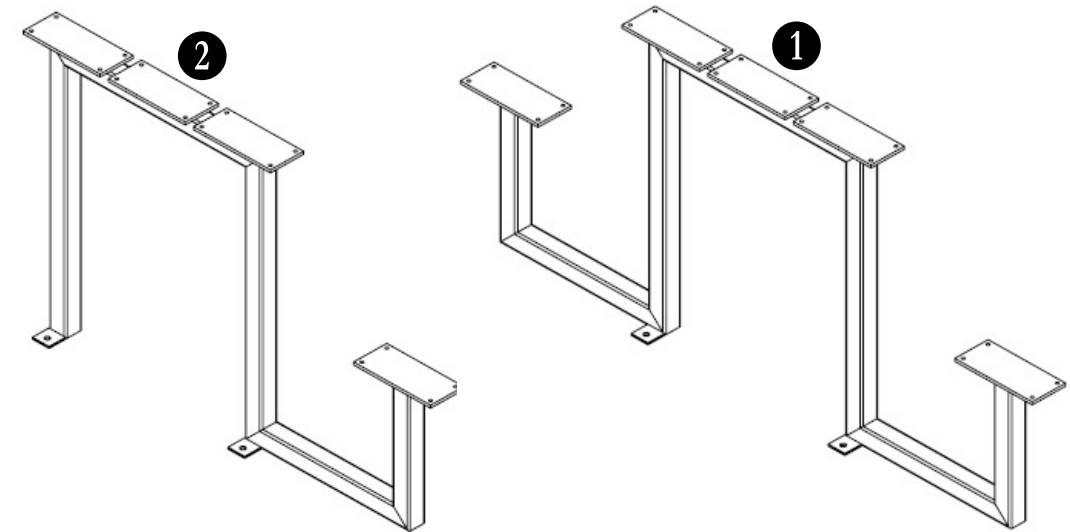
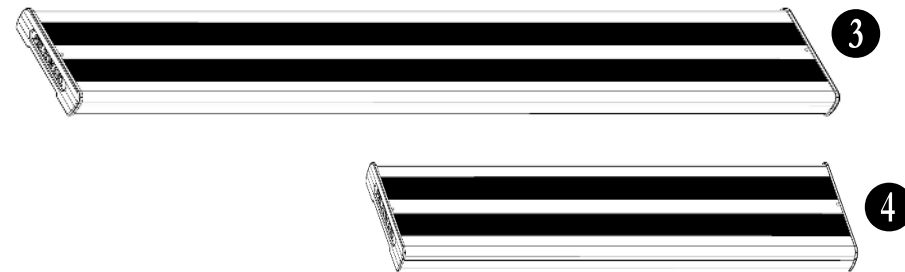
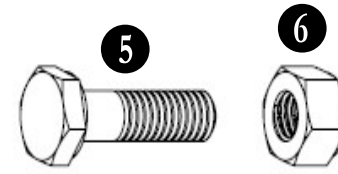

Place three table planks 3 upside down and close together on the ground as illustrated.

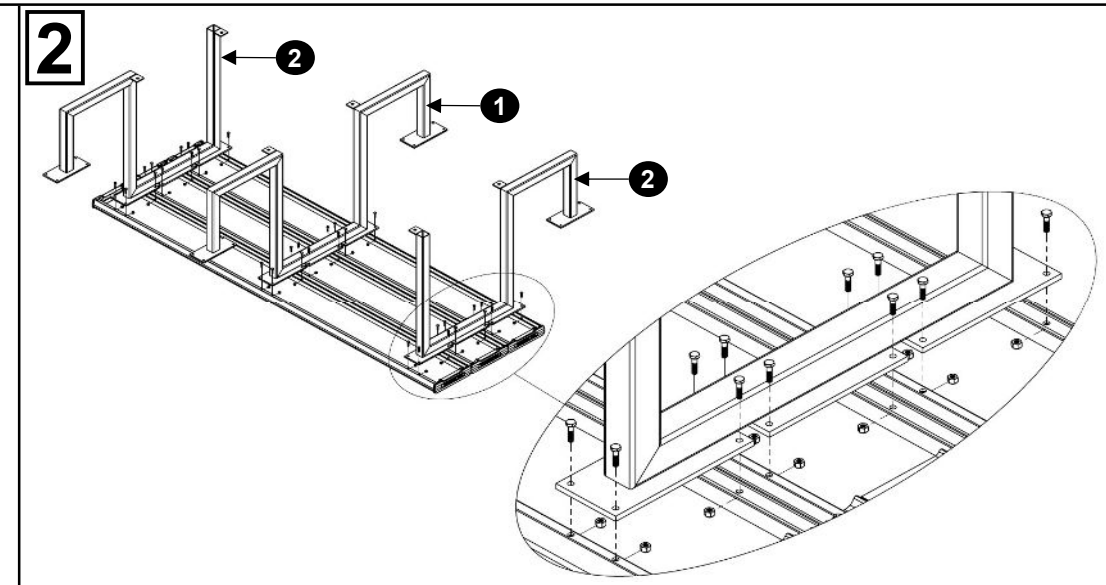

Attach central base frame 1 and two side frames 2 to three planks 3 in step 1 by using bolts 5 and nuts 6 as illustrated. Note that all fixing lugs on base frames 1 & 2 face inwards.

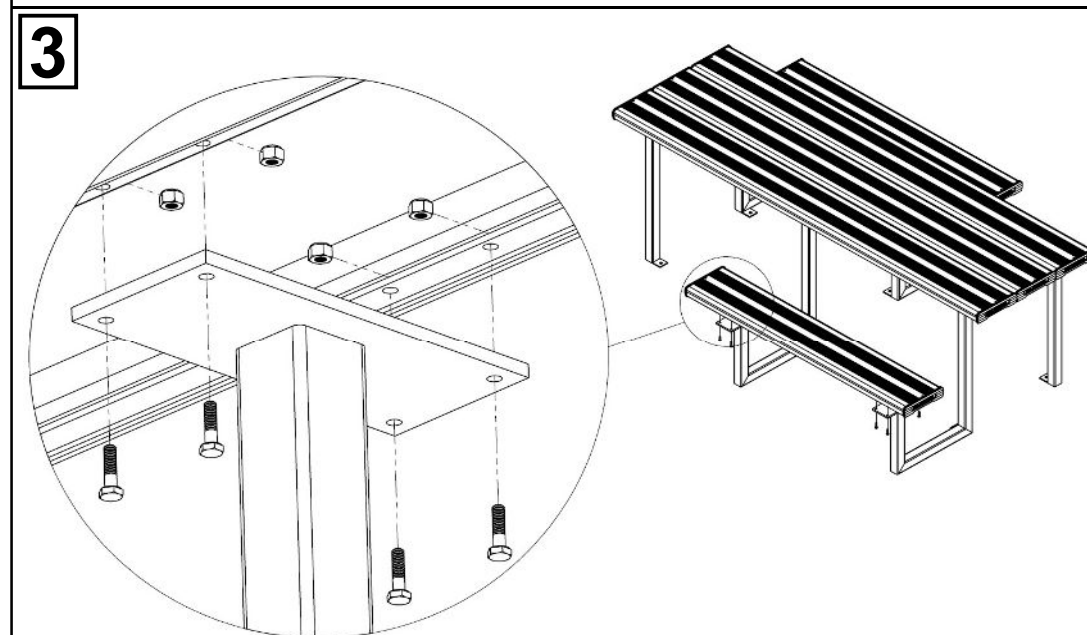

Turn the assembly in step 2 up, then attach two seat planks 4 onto fixing plates by using bolts 5 and nuts 6 as illustrated.

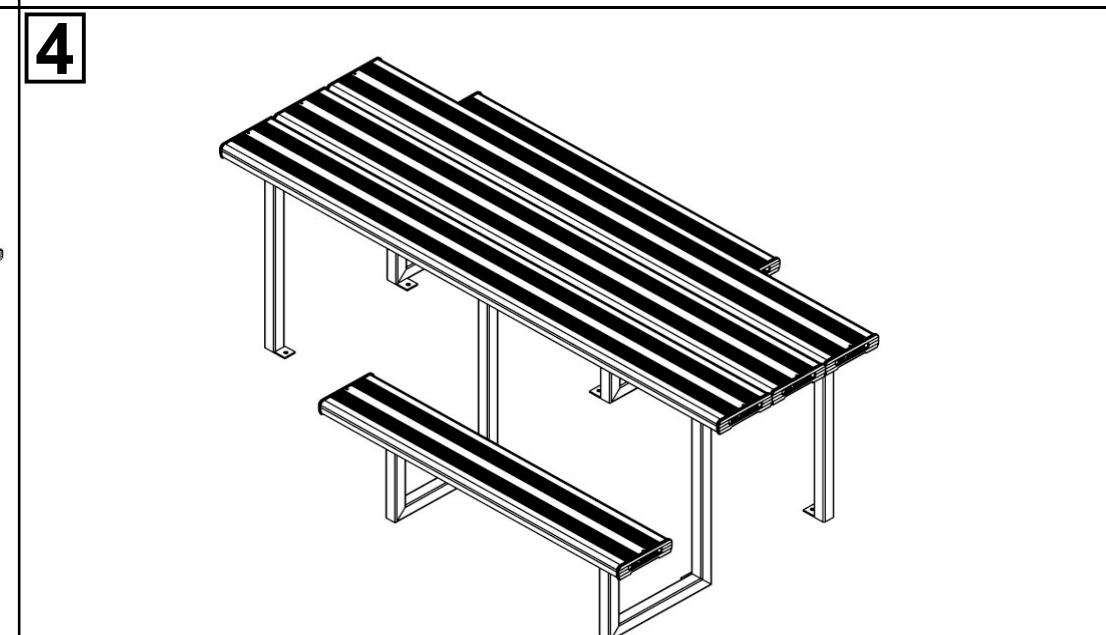

Tighten all hexagonal head bolts with spanners and appropriate tools. Then attach the whole assembly to the ground by using M12 dyna-bolts preferably, on each frame lug.