

ASSEMBLY INSTRUCTION

Thank You

FOR CHOOSING FELTON INDUSTRIES

JUMBO PARK SETTING
[Code No: FELJPS]



"This product has been manufactured in Australia to the highest quality standard, guaranteeing proven quality, durability and low maintenance"



☎ 1800 22 00 55

🖨 1800 05 91 58

✉ sales@felton.net.au

🌐 www.felton.net.au



Felton Industries Pty Ltd | ABN: 130 687 240



WARNING: This assembly required two or more people as lifting is involved. **Please ensure bolts and nuts are only finger-tightened throughout assembly for flexibility in lining up components.** Bolt and nuts should be securely tightened in place when instructed to do so. Please check all components are included before proceeding with the assembly

ITEM	DESCRIPTION	Qty
1	FELJPS_TABLE FRAME	2
2	FELJPS_SEAT FRAME	4
3	FELJPS_PLANK L1800	6
4	FELJPS_PLANK L1000	2
5	AS-NZS 2465 Bolt - 0.25 x1	64
6	AS-NZS NYLON Nut - 0.25	64
7	AS-NZS 2465 Bolt - 0.5 x 3	8
8	AS-FLAT WASHER - 0.5	16
9	AS-NZS NYLON Nut - 0.5	8

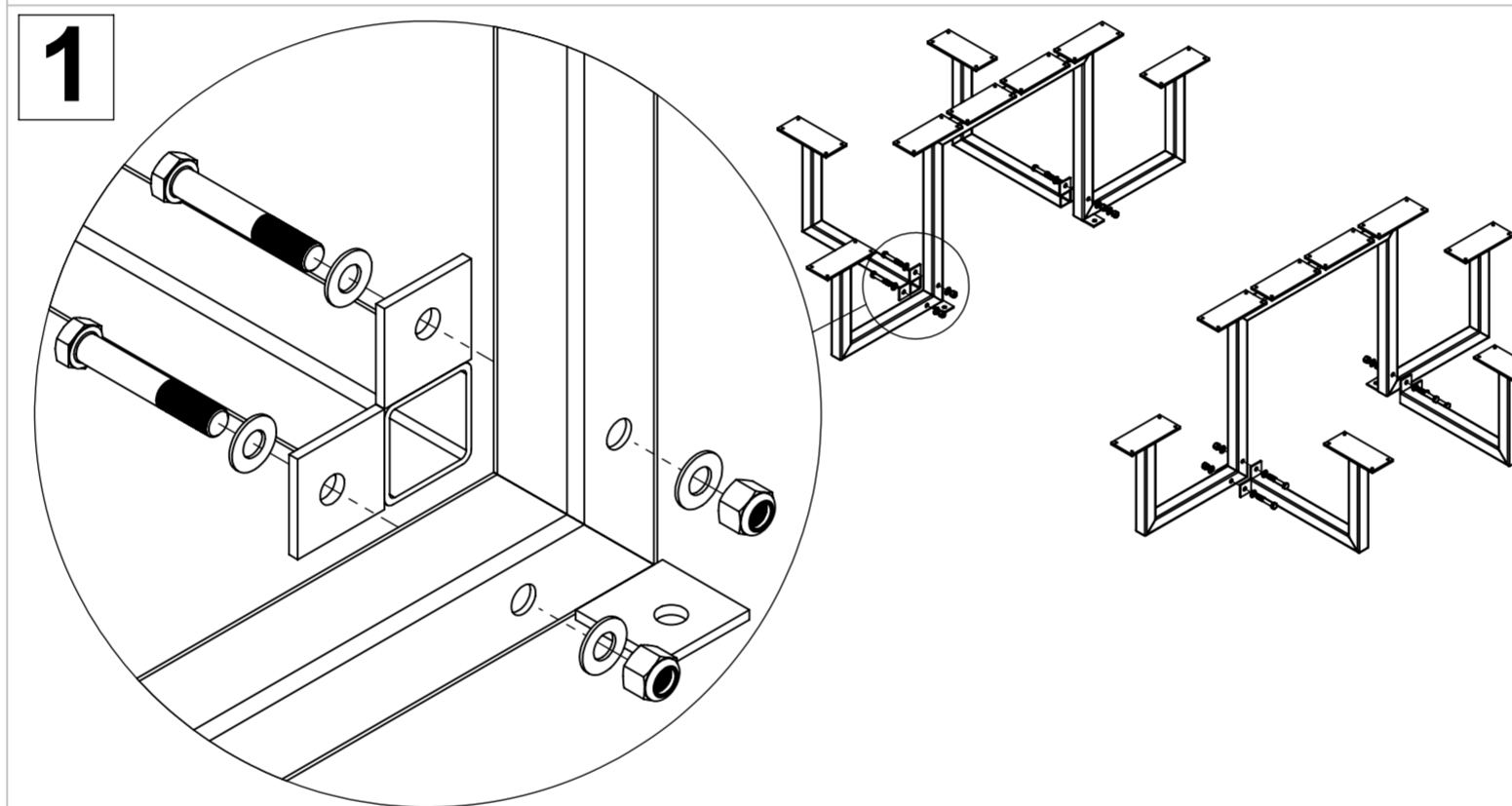
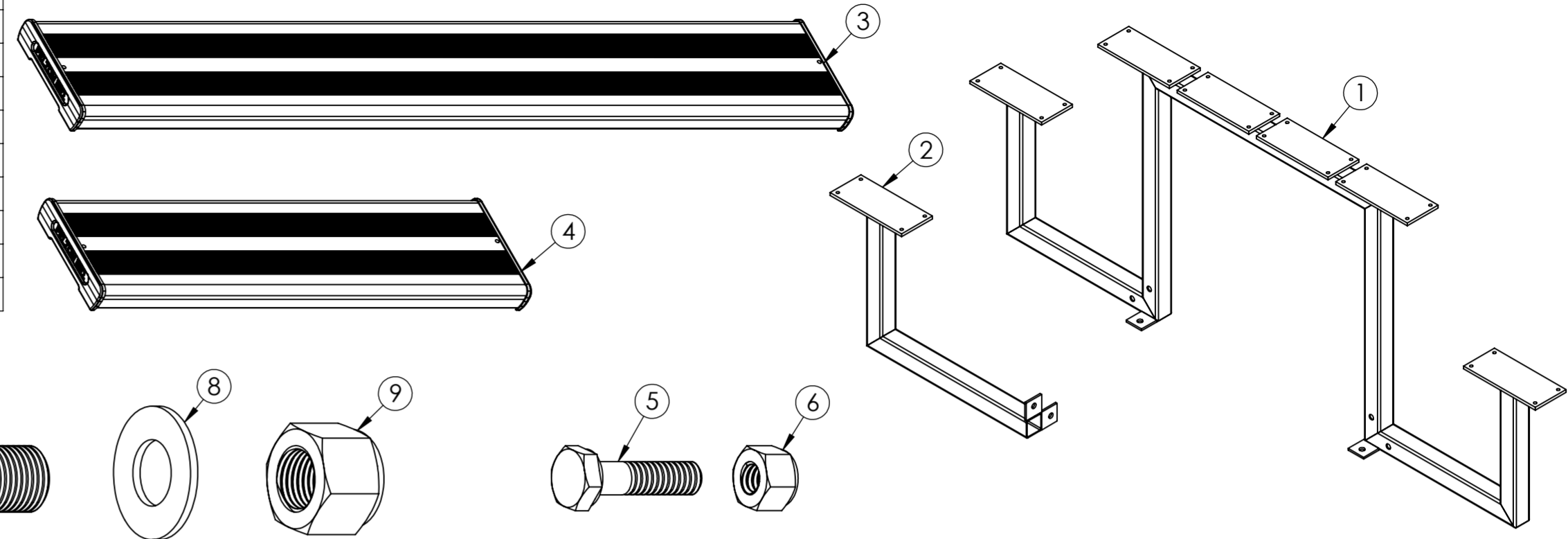

Attach four seat frames (2) to two table frames (1) by using bolts (7), washers (8) and nuts (9) to create two main frames as illustrated. **Note that all fixing lugs on table frames (1) face inwards.**

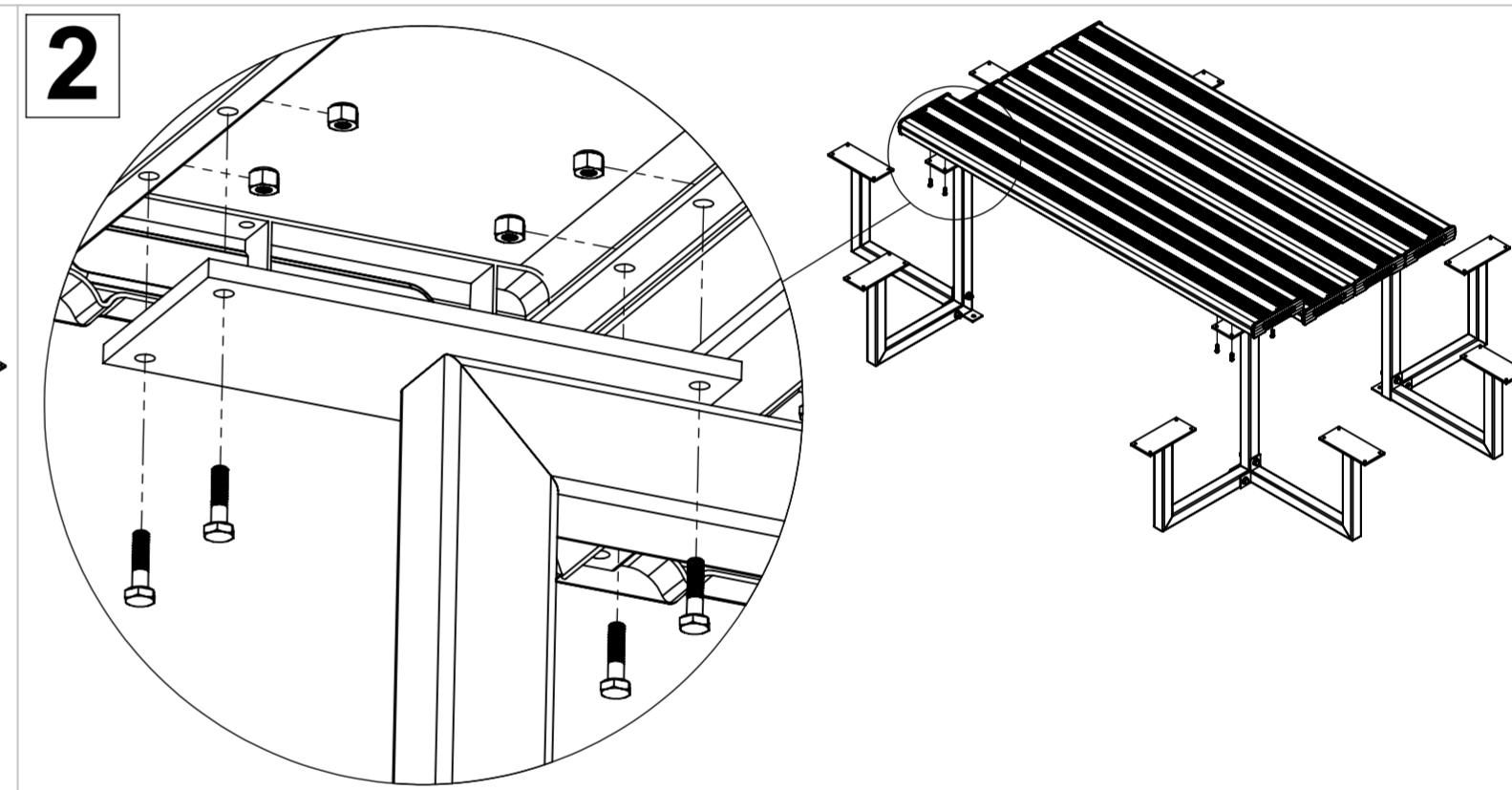

Attach four planks (3) to two main frames in step 1 by using bolts (5) and nuts (6) as illustrated.

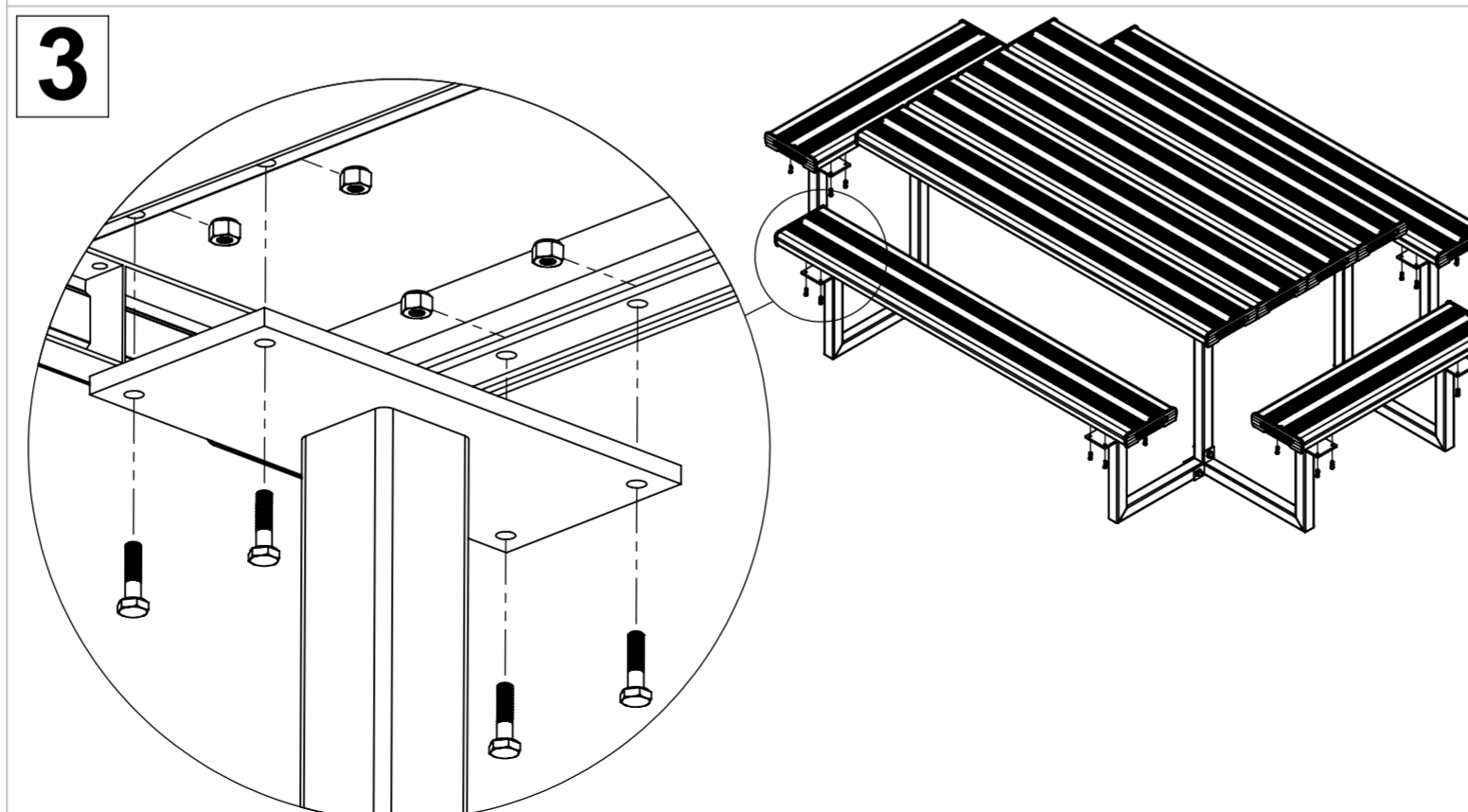

Attach two remaining planks (3) and two planks (4) onto fixing plates by using bolts (5) and nuts (6) as illustrated.

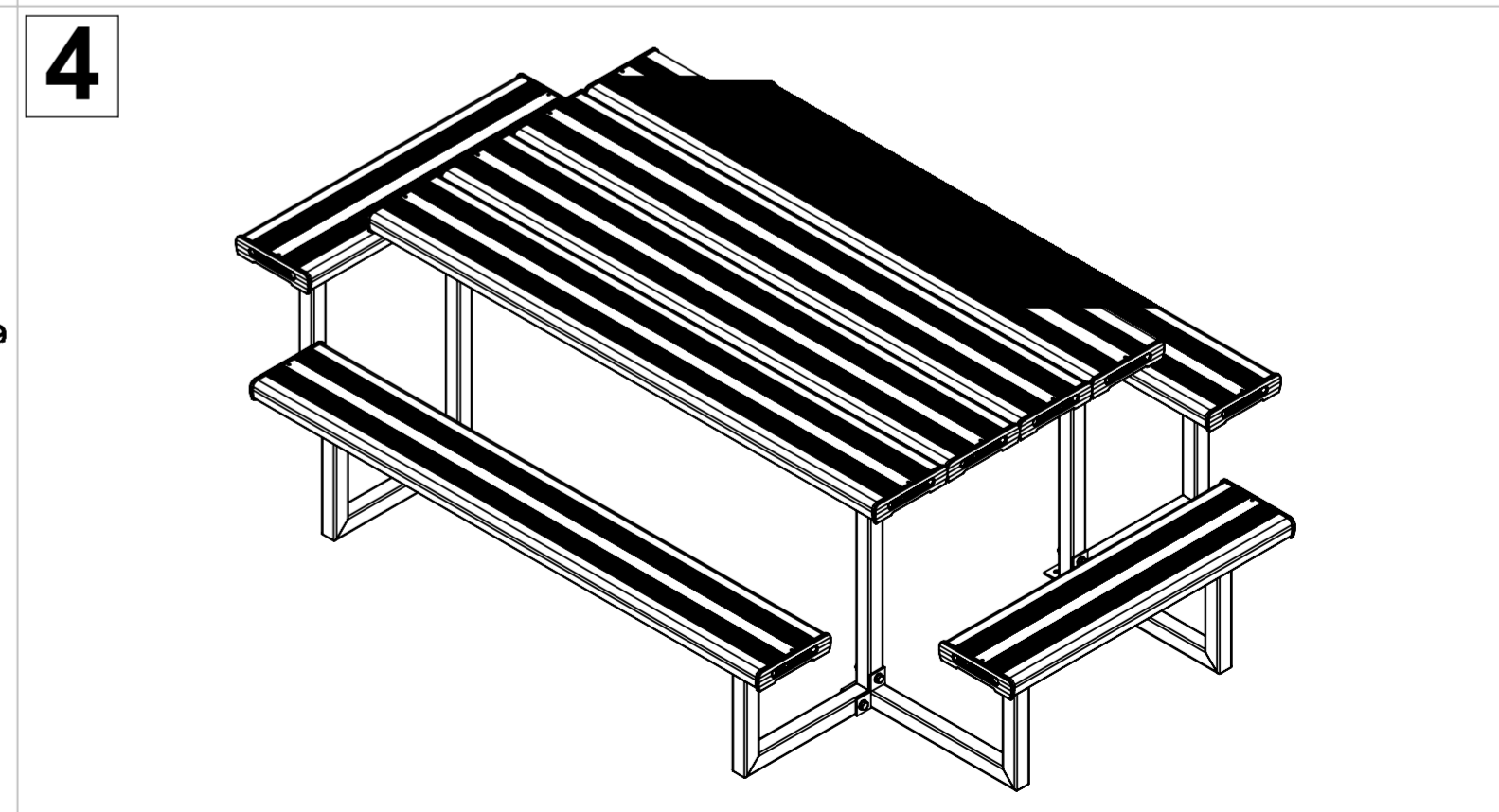

Tighten all hexagonal head bolts with spanners and appropriate tools. Then attach the whole assembly to the ground by using M12 dyna-bolts preferably, on each frame lug.