

ASSEMBLY INSTRUCTION

Thank You

FOR CHOOSING FELTON INDUSTRIES

WHEELIE BIN SURROUND 240 Ltr
[Code No:FELMB524]



"This product has been manufactured in Australia to the highest quality standard, guaranteeing proven quality, durability and low maintenance"



☎ 1800 22 00 55

🖨 1800 05 91 58

✉ sales@felton.net.au

🌐 www.felton.net.au



Felton Industries Pty Ltd | ABN: 17 130 687 240



WARNING: This assembly required two or more people as lifting is involved. **Please ensure bolts and nuts are only finger-tightened throughout assembly for flexibility in lining up components.** Bolt and nuts should be securely tightened in place when instructed to do so. Please check all components are included before proceeding with the assembly

ITEM	DESCRIPTION	Qty
1	FELMB524_BACK PANEL	1
2	FELMB524_LEFT SIDE PANEL	1
3	FELMB524_RIGHT SIDE PANEL	1
4	FELMB524_FRONT DOOR	1
5	FELMB524_TOP LID	1
6	FELMB524_HINGE 80x60x1.6	2
7	RIVET	12
8	KEYWAY CAM LOCK	1
9	ISO 4017 Screw - M6 x 16	29
10	AS 1112.1 Nut - M6	29

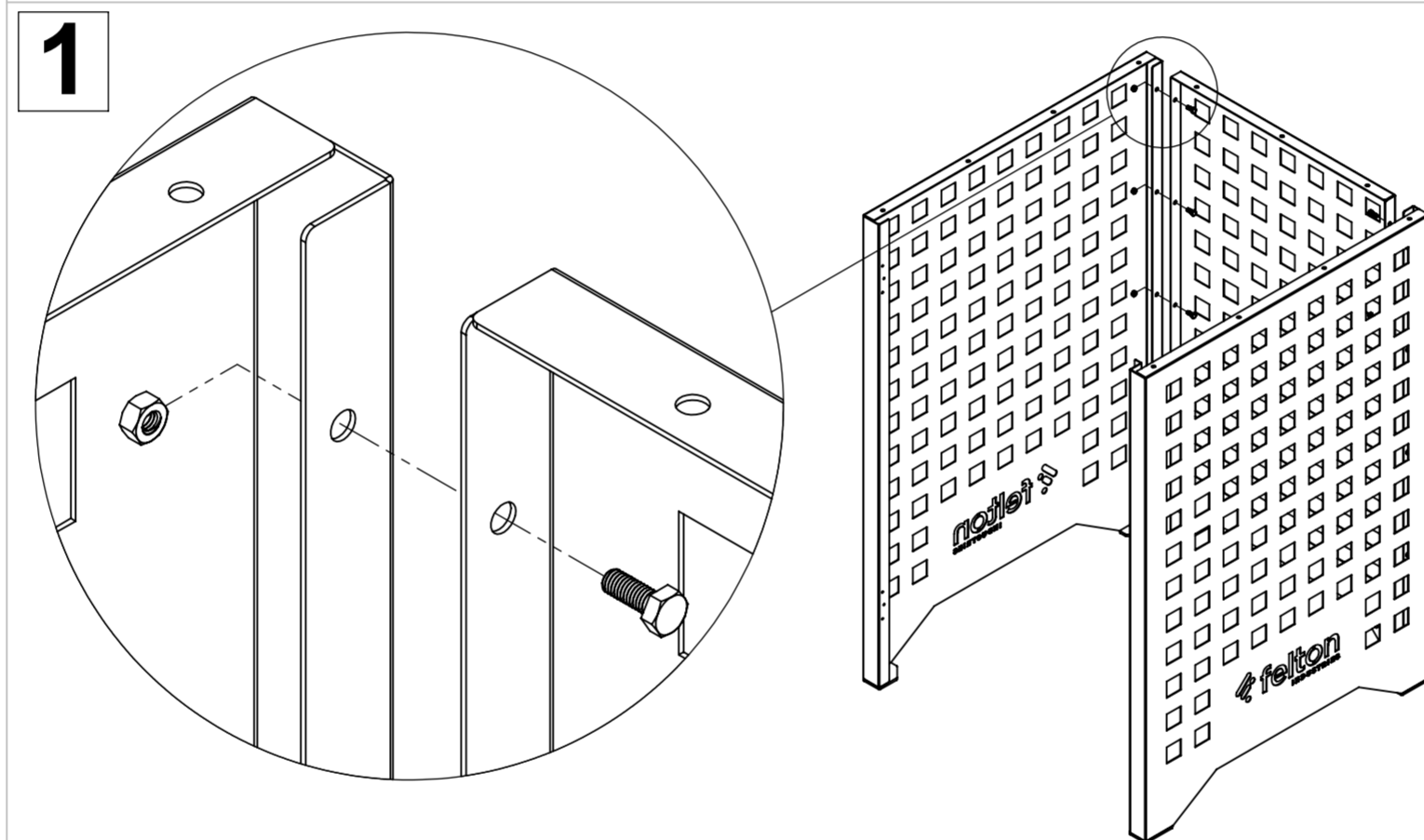
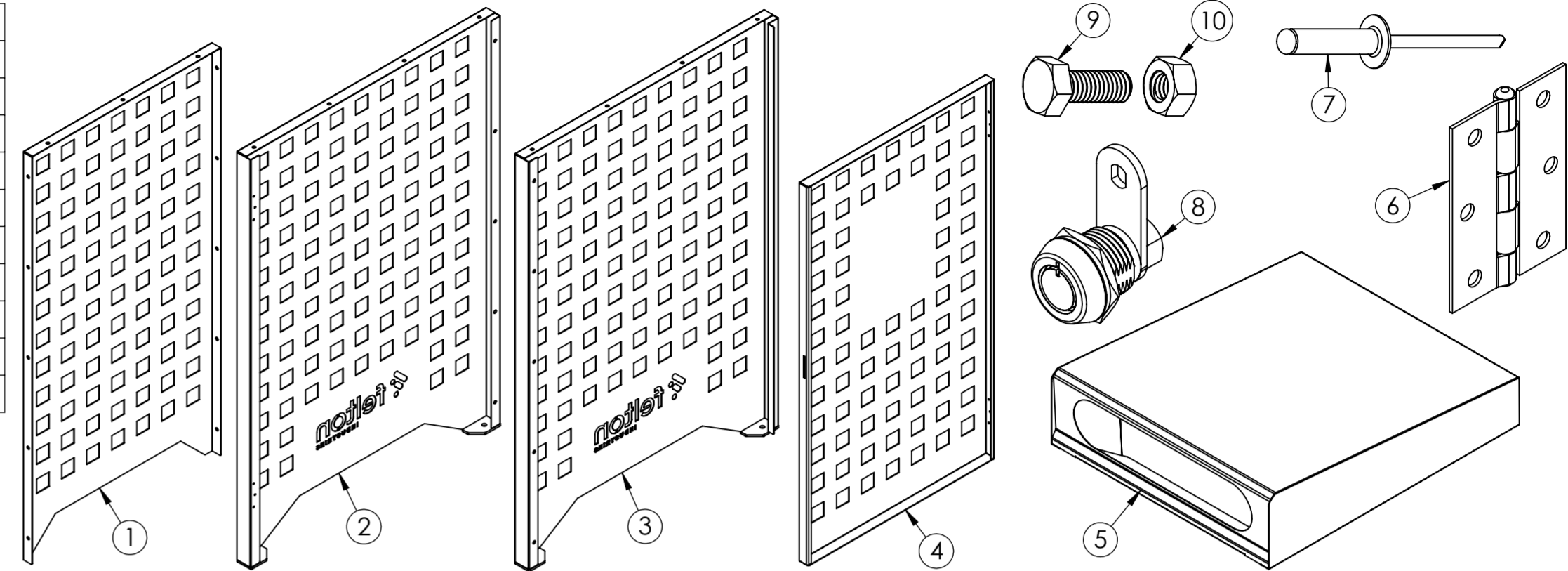

Attach the left side panel (2) and the right side panel (3) to the back panel (1) by using screws (9) and nuts (10) as illustrated.

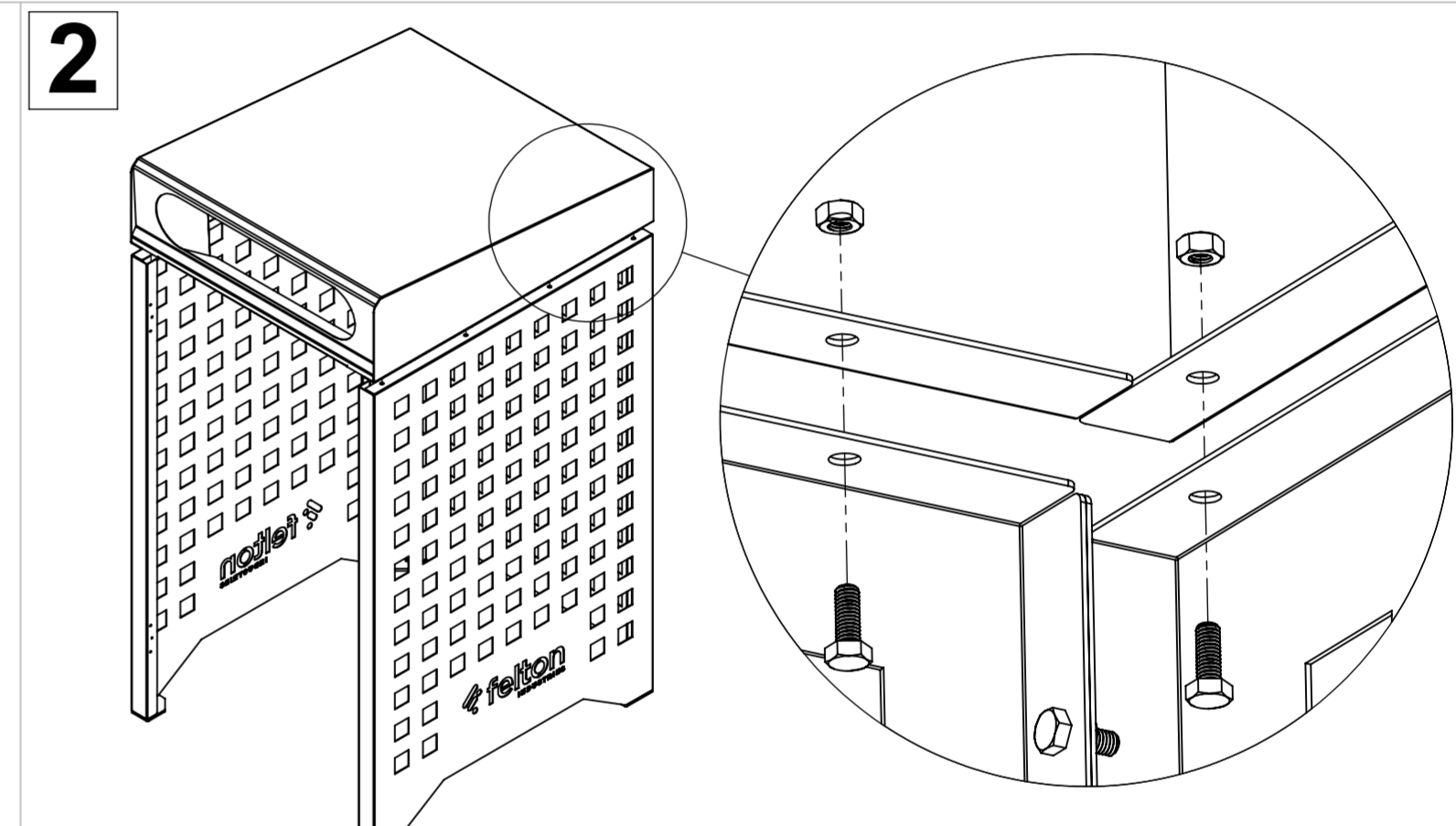

Attach the top lid (5) to the sub-assembly unit in step 1 by using screws (9) and nuts (10) as illustrated.

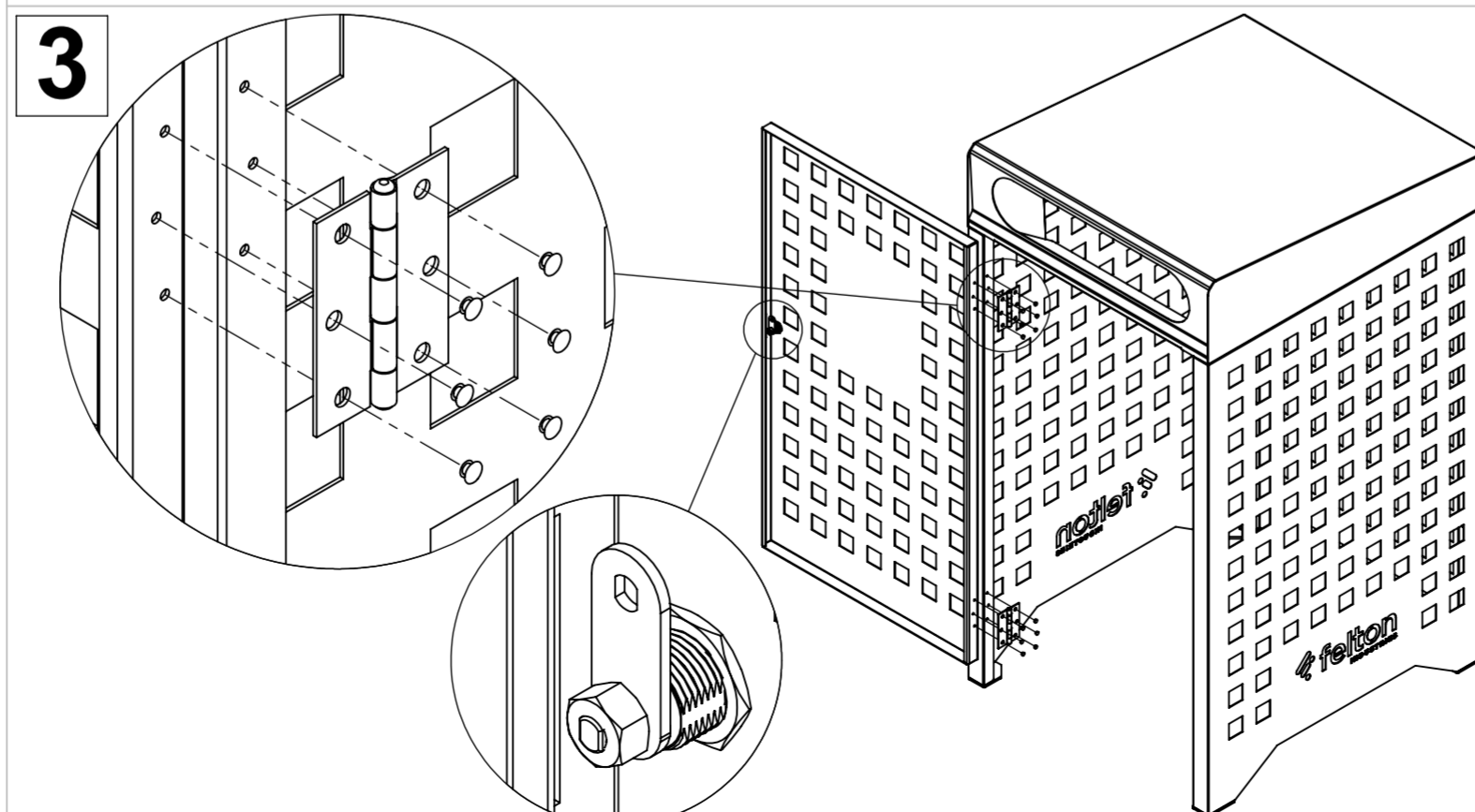

Attach two hinges (6) to the door panel (4) and the left panel (2) by rivets (7) as illustrated (using rivet gun). Note that the hinge pins face outwards. Then attach the lock (8) to the door panel (4).

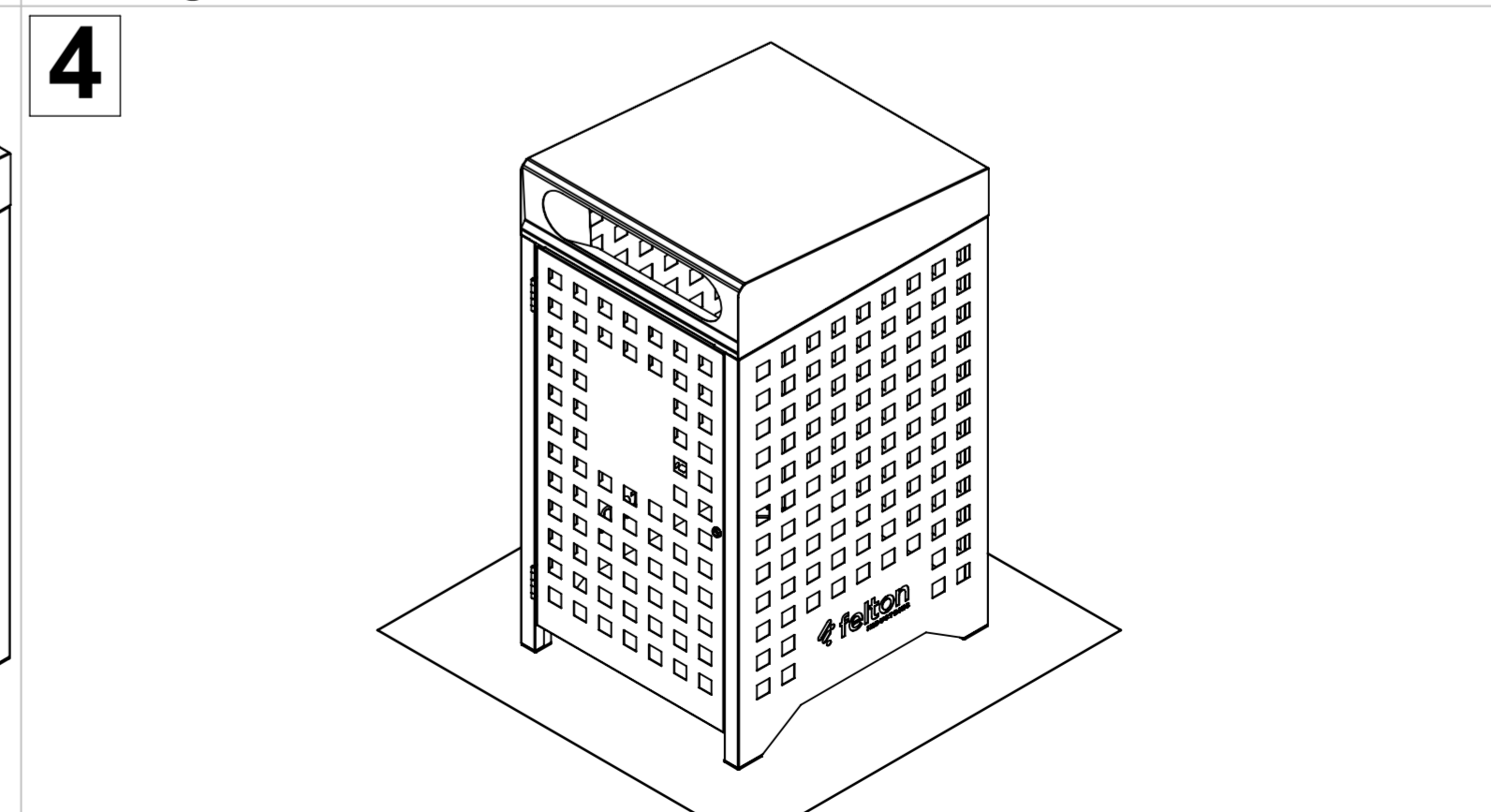

Tighten all hexagonal head screws with spanners and appropriate tools. Then fix the whole bin to the ground by using dyna-bolts preferably, on 4 mount plates.