

# ASSEMBLY INSTRUCTION

*Thank You*

FOR CHOOSING FELTON INDUSTRIES

**BBQ SHELTER**  
[Code No: FELSPSH]



"This product has been manufactured in Australia to the highest quality standard, guaranteeing proven quality, durability and low maintenance"



☎ 1800 22 00 55

📄 1800 05 91 58

✉ sales@felton.net.au

🌐 www.felton.net.au



Felton Industries Pty Ltd | ABN: 17 130 687 240



**WARNING:** This assembly required two or more people as lifting is involved. **Please ensure bolts and nuts are only finger-tightened throughout assembly for flexibility in lining up components.** Bolt and nuts should be securely tightened in place when instructed to do so. Please check all components are included before proceeding with the assembly

ITEM	DESCRIPTION	Qty
1	FELSPSH_BASE FRAME	2
2	FELSPSH_ROOF ARCH BAR	2
3	FELSPSH_ROOF BAR	5
4	CORRUGATED CUSTOM Orb .42	4
5	AS-NZS 2465 Bolt - 1/2" x 4.5"	8
6	AS-NZS 2465 Bolt - 1/2" x 3"	10
7	AS-FLAT Washer - 1/2"	36
8	AS-NZS NYLON Nut - 1/2"	18
9	AS-Screw-ST5.5x39	70

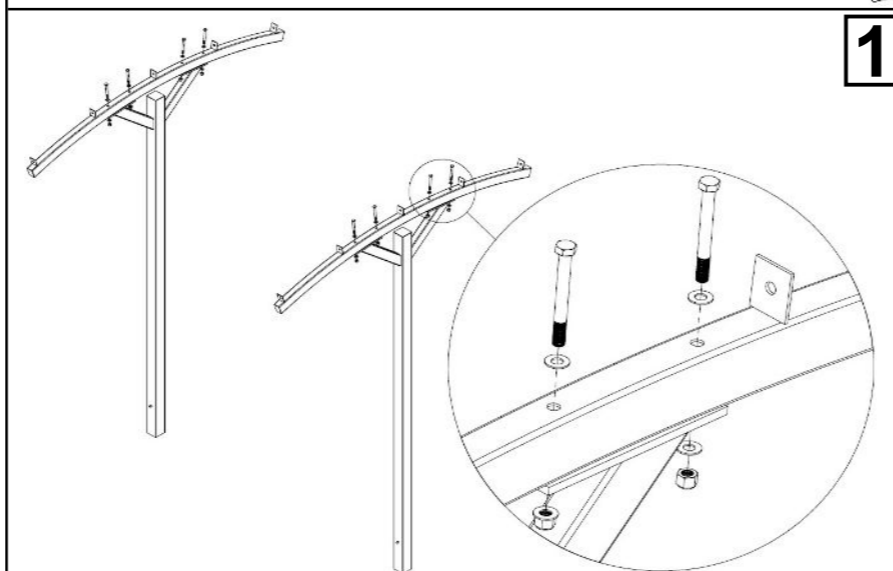
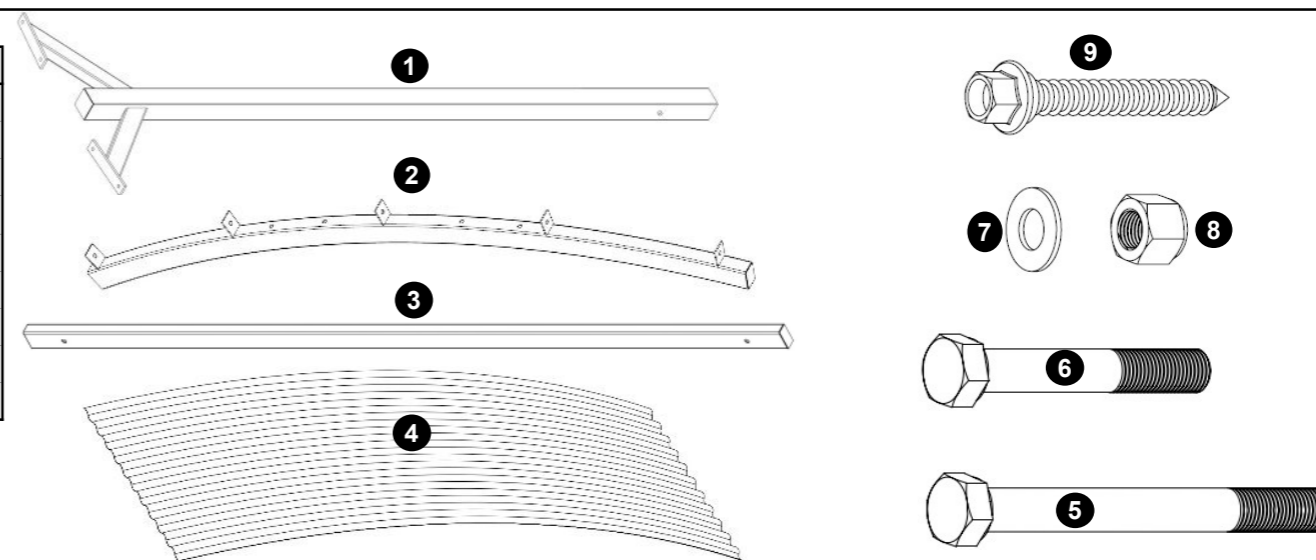

Attach two base frames **1** and two roof arch bars **2** by using bolts **5**, washers **7**, and nuts **8** to create two main columns as illustrated.

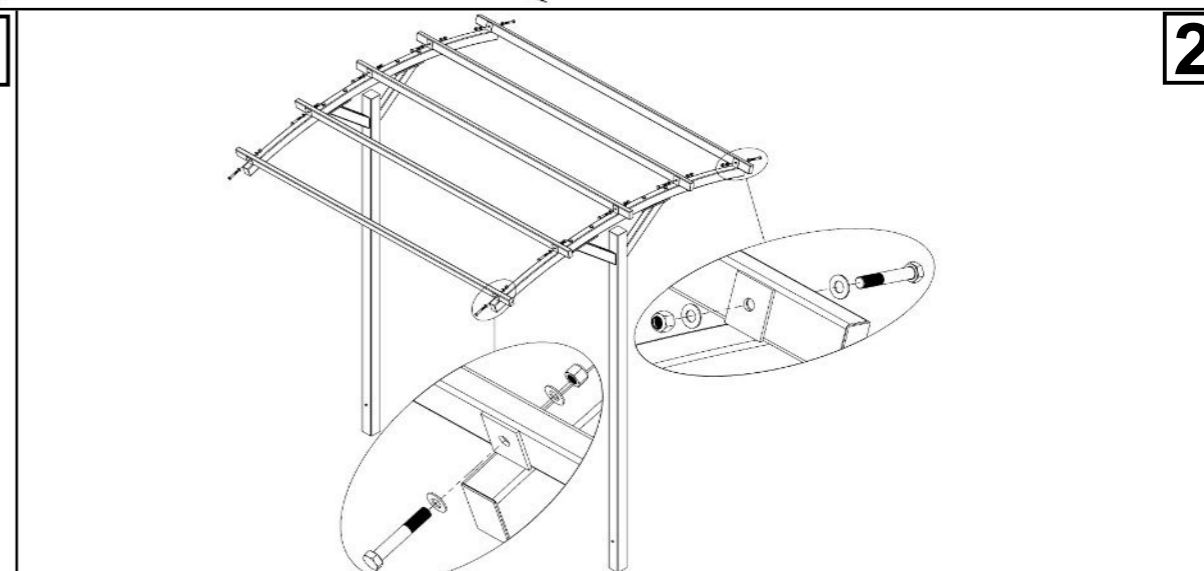

Attach five roof bars **3** to connect the two columns in step 1 by using bolts **6**, washers **7**, and nuts **8** as illustrated. **Note that the two main columns are lined up.** Then tighten all hexagonal head bolts with spanners and appropriate tools.

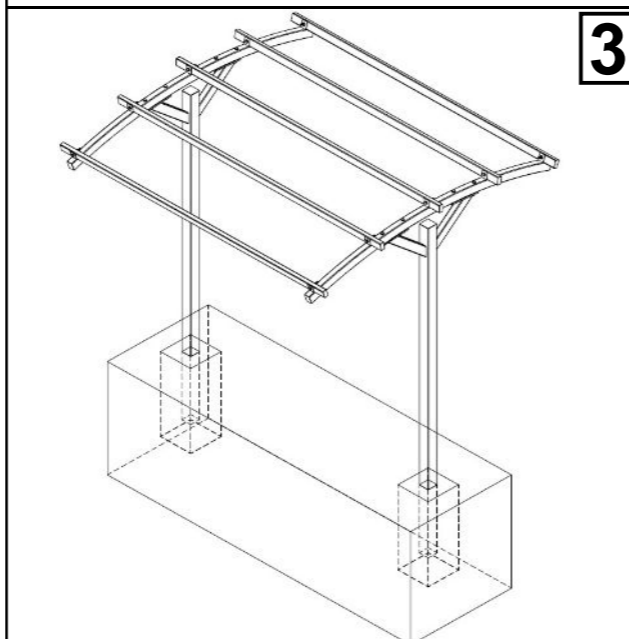

Embed the whole assembly 600 mm to the concrete base as per technical recommendation in "SPECIFICATION DRAWING"

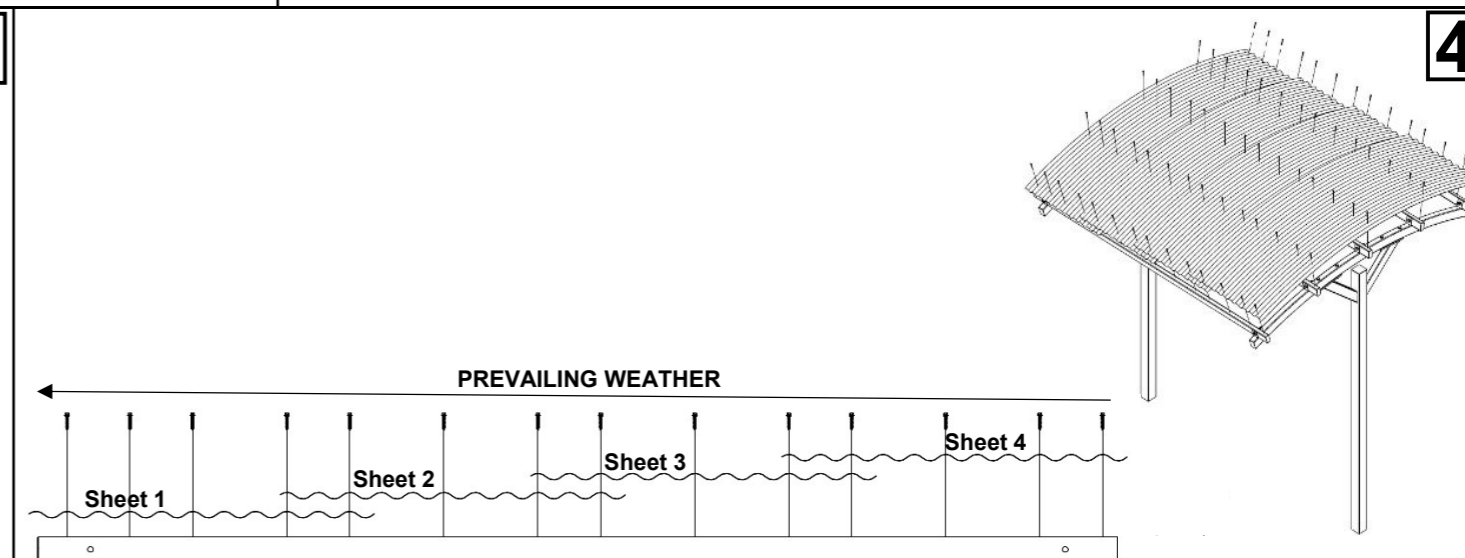

Fasten four corrugated roofs **4** to the assembly in step 3 by screws **9**. Ensure that the roofs' overlapping position and screws' position are conformed with the illustration in the picture. Note that the valleys of sheets should be turned-down at lower ends, and turned-up at upper ends as recommendation from manufacturer.