

ASSEMBLY INSTRUCTION

Thank You

FOR CHOOSING FELTON INDUSTRIES

DOUBLE SIDED COMBO
[Code No: GHDS18]



"This product has been manufactured in Australia to the highest quality standard, guaranteeing proven quality, durability and low maintenance"



☎ 1800 22 00 55

🖨 1800 05 91 58

✉ sales@felton.net.au

🌐 www.felton.net.au



Felton Industries Pty Ltd | ABN: 17 130 687 240



WARNING: This assembly required two or more people as lifting is involved. **Please ensure bolts and nuts are only finger-tightened throughout assembly for flexibility in lining up components.** Bolt and nuts should be securely tightened in place when instructed to do so. Please check all components are included before proceeding with the assembly

ITEM	DESCRIPTION	Qty
1	GHDS18_MAIN FRAME	1
2	GHDS18_SEAT FRAME	4
3	GHDS18_PLANK L1200	2
4	COAT HOOK	6
5	AS-NZS 2465 Bolt - 3/8" x 3"	4
6	AS-NZS Nylon Washer - 3/8"	8
7	AS-NZS Nylon Nut - 3/8"	4
8	AS-NZS 2465 Bolt - 1/4" x 1"	16
9	AS-NZS Nylon Nut - 1/4"	16
10	Self-Tapping Screw - ST2.9x13	24

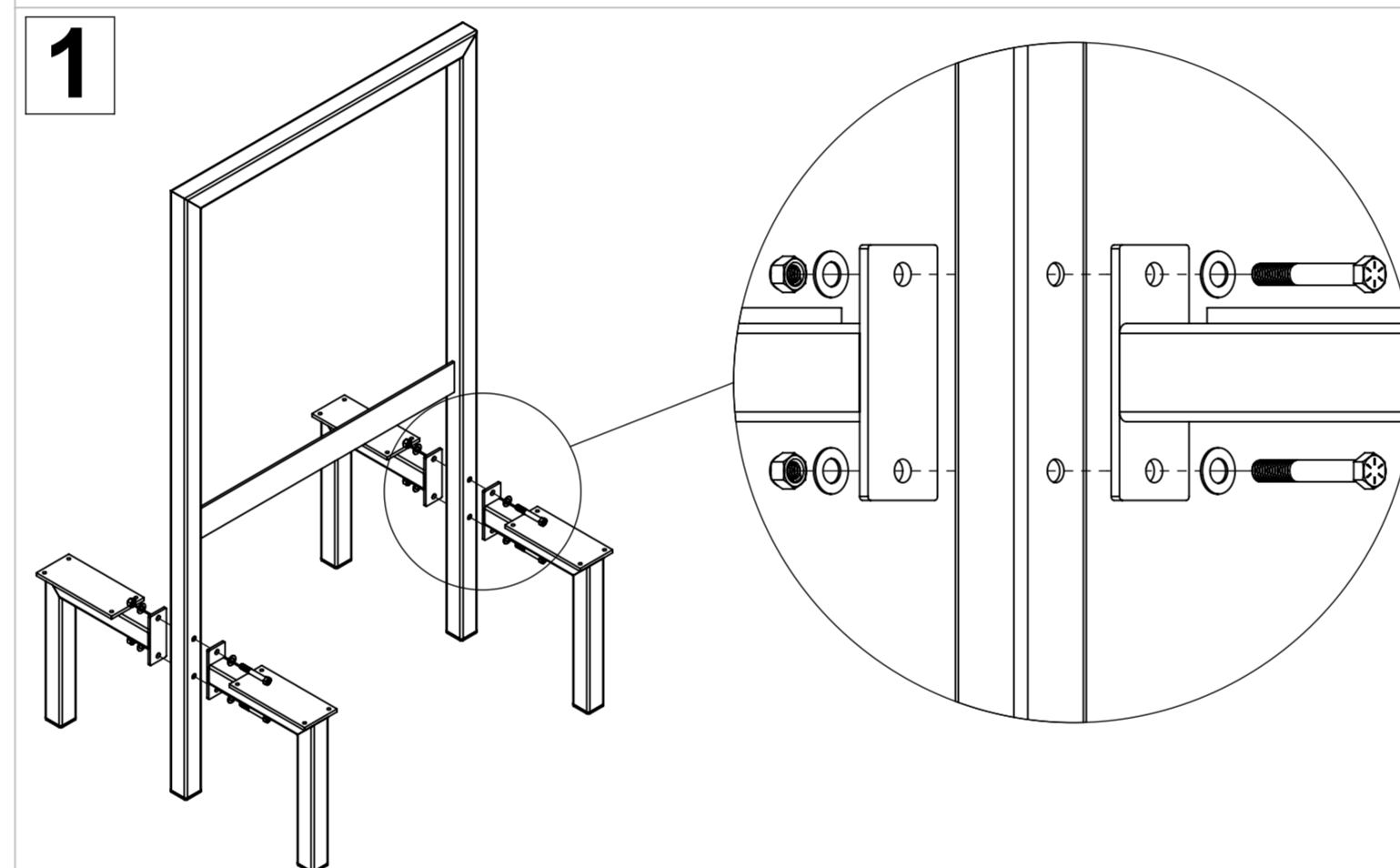
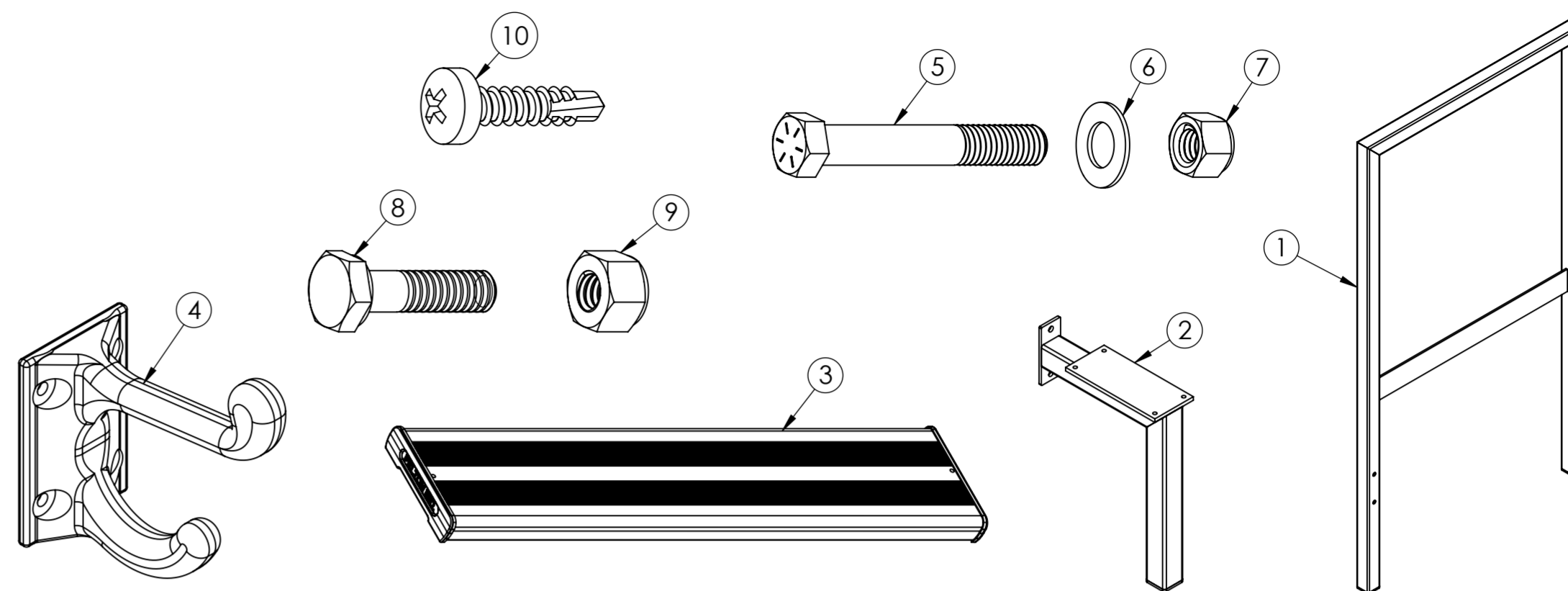

Attach four seat frames (2) to the main frame (1) by using bolts (5), washers (6) and nuts (7) as illustrated

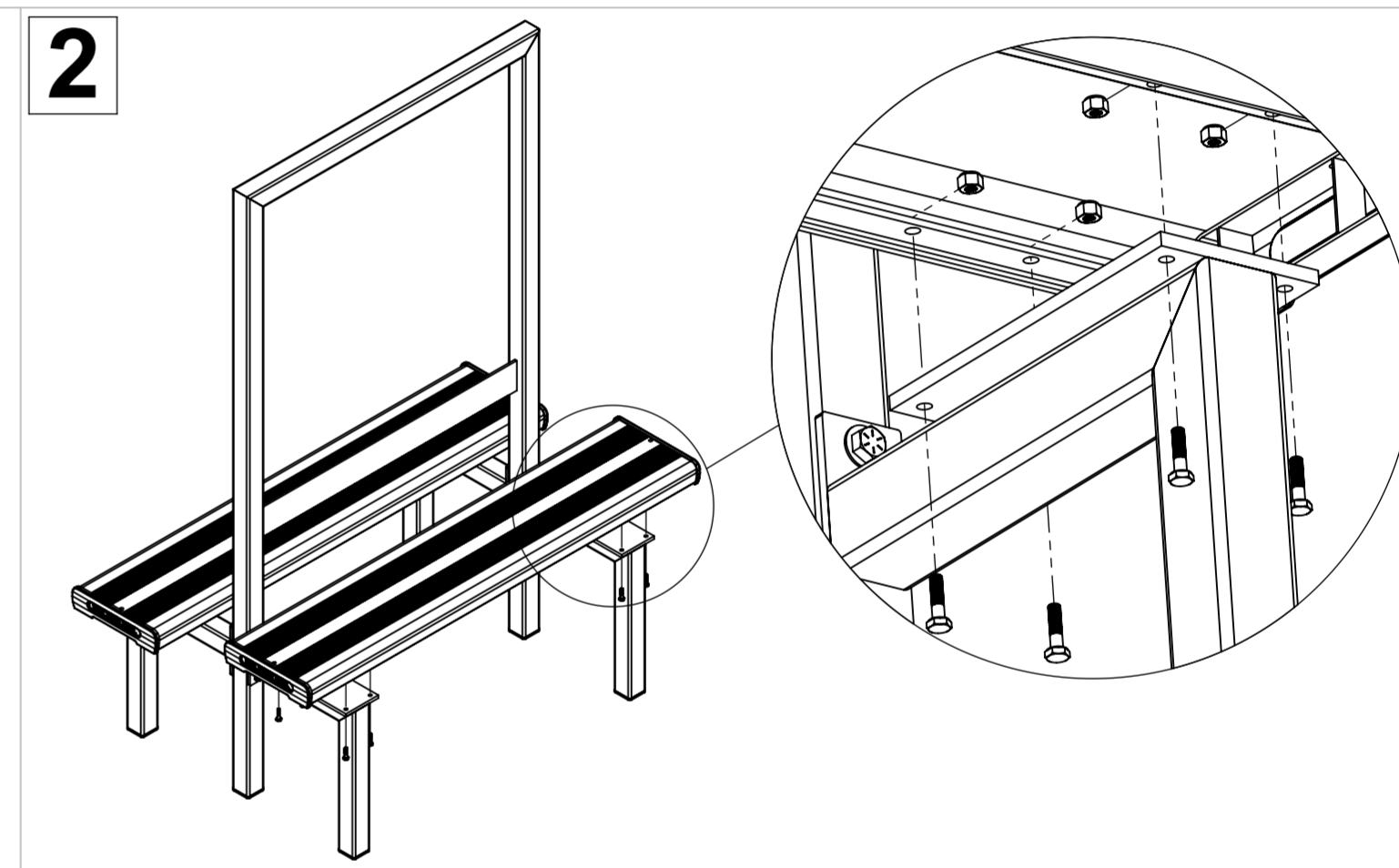

Attach two seat planks (3) to the assembly in step 1 by using bolts (8) and nuts (9) as illustrated

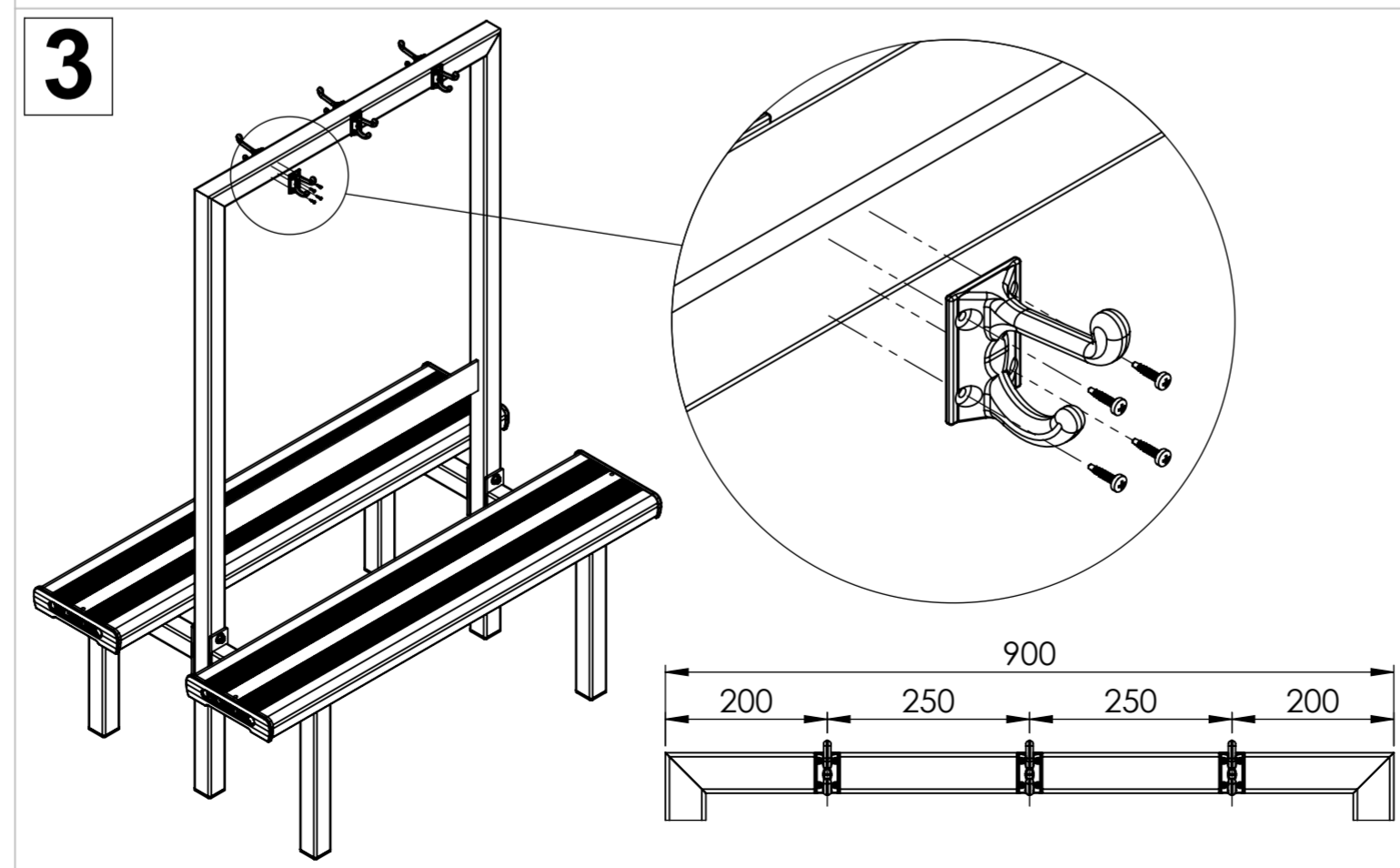

Attach six coat hooks (4) to the top bar of the frame by using self-tapping screws (10) as illustrated

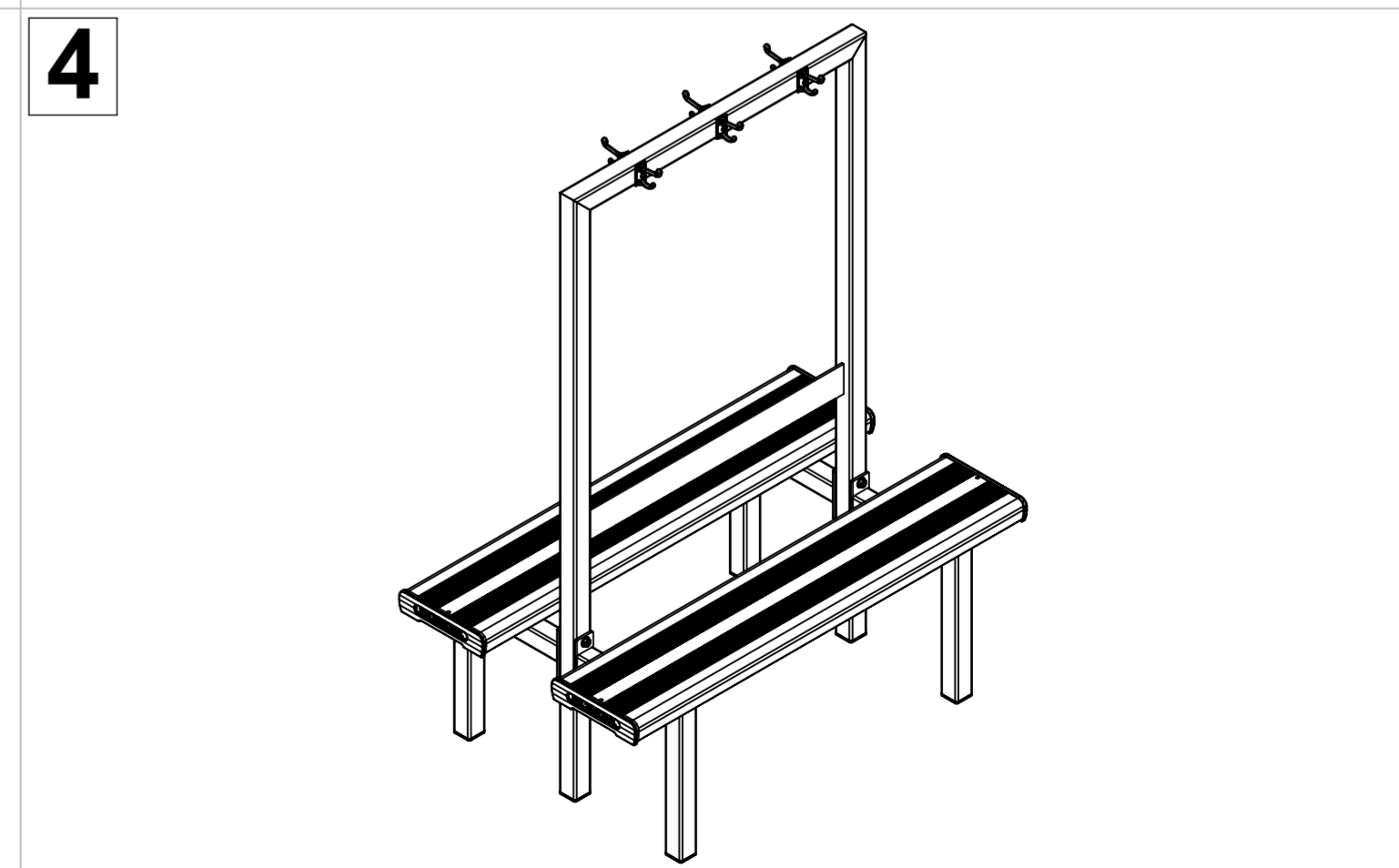

Tighten all hexagonal head bolts with spanners and appropriate tools