

ASSEMBLY INSTRUCTION

Thank You

FOR CHOOSING FELTON INDUSTRIES

BURBUNG BIRRANG BENCH SEAT
[Code No: TRRBS]



"This product has been manufactured in Australia to the highest quality standard, guaranteeing proven quality, durability and low maintenance"



☎ 1800 22 00 55

📠 1800 05 91 58

✉ sales@felton.net.au

🌐 www.felton.net.au



Felton Industries Pty Ltd | ABN: 17 130 687 240



WARNING: This assembly required two or more people as lifting is involved. **Please ensure bolts and nuts are only finger-tightened throughout assembly for flexibility in lining up components.** Bolt and nuts should be securely tightened in place when instructed to do so. Please check all components are included before proceeding with the assembly

ITEM	DESCRIPTION	Qty
1	TRRBS_FRAME BRACKET BOTTOM	2
2	TRRBS_FRAME BRACKET TOP	2
3	TRRBS_SEATING BRACKET	2
4	TRRBS_STRAP	1
5	TRRBS_SEATING PLANK	2
6	BUTTON SCREW_ISO 7380 - M8 x 20	16
7	AS-NZS 2465 Bolt - 0.25in x 0.5in	24
8	AS-NZS Nut - 0.25in	24

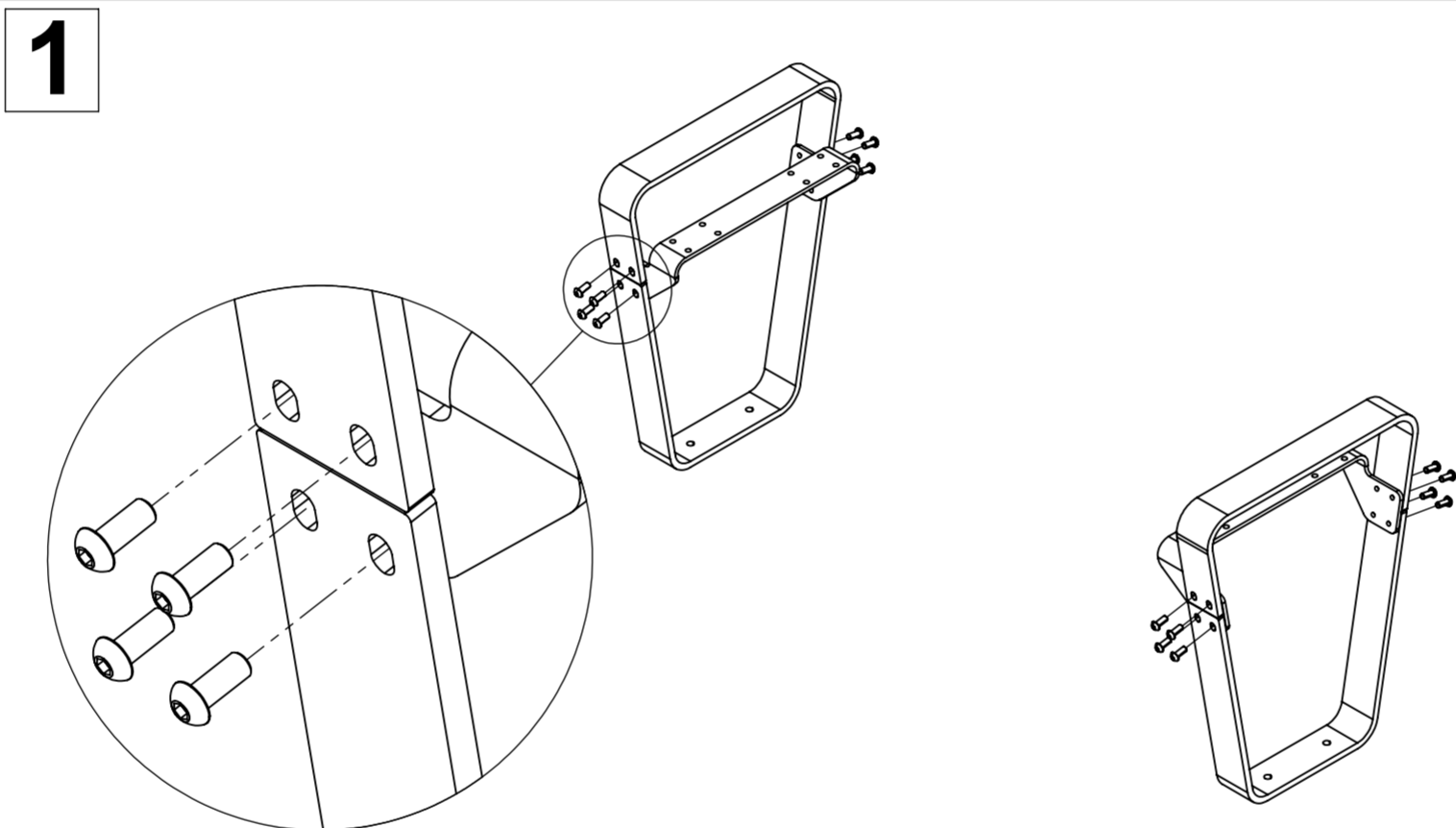
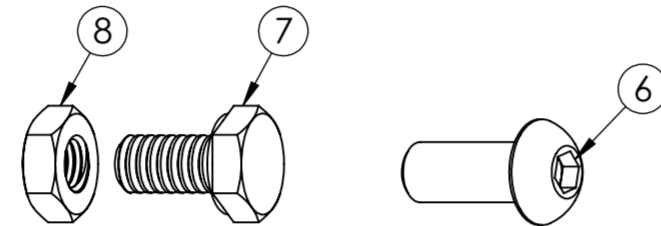
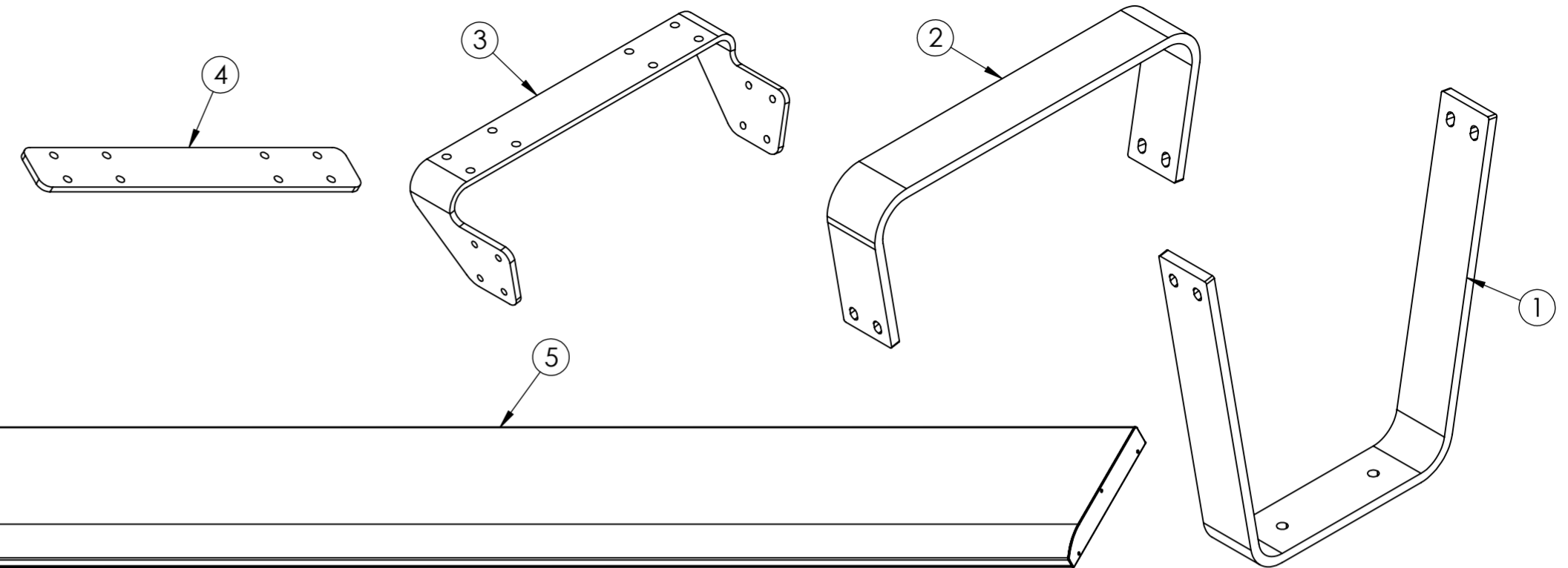

Attach frame brackets ① ; ② & ③ by using button head screw ⑥ to create two main frames as illustrated.

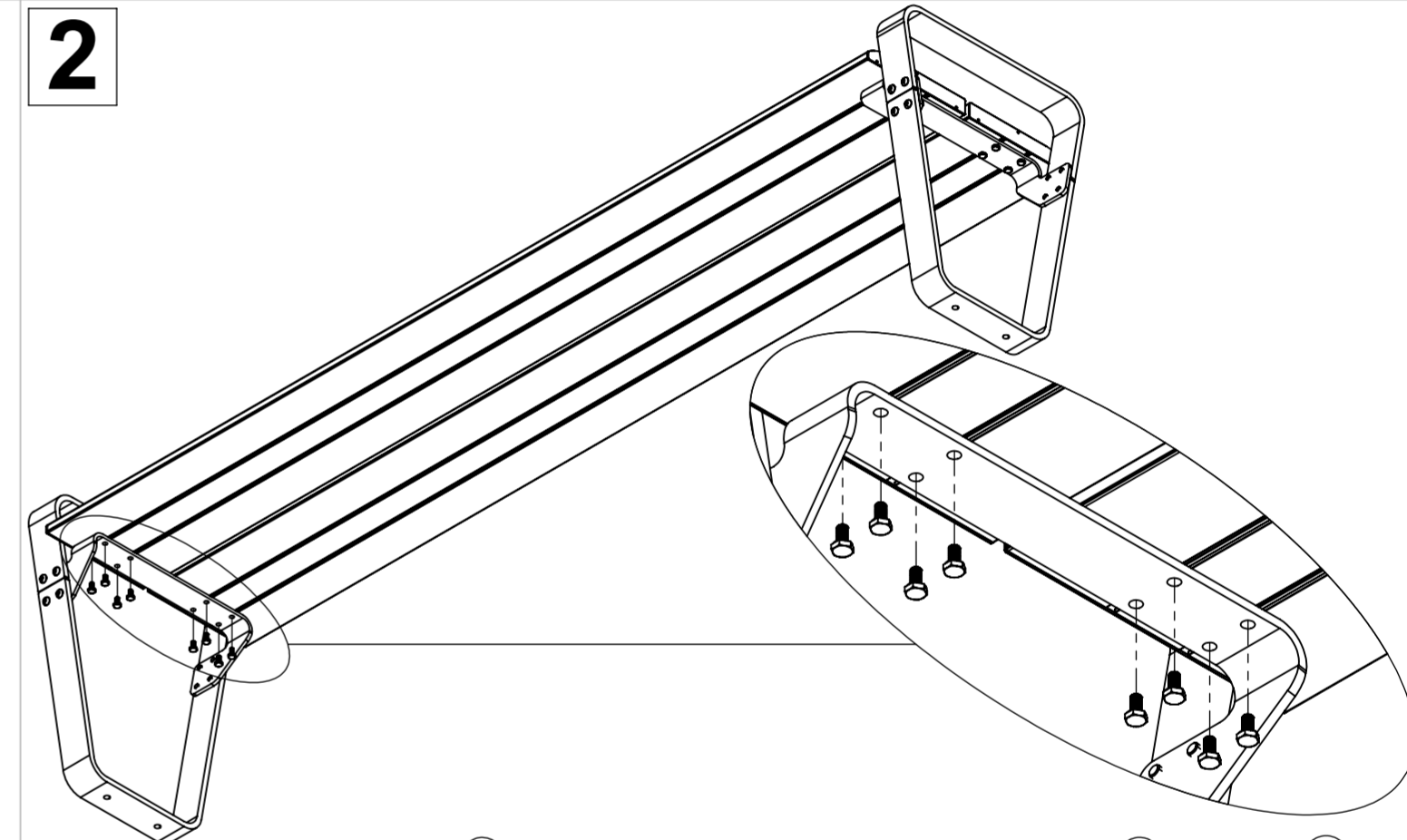

Attach two seating planks ⑤ to two main frames in step 1 by using bolts ⑦ and nuts ⑧ as illustrated.

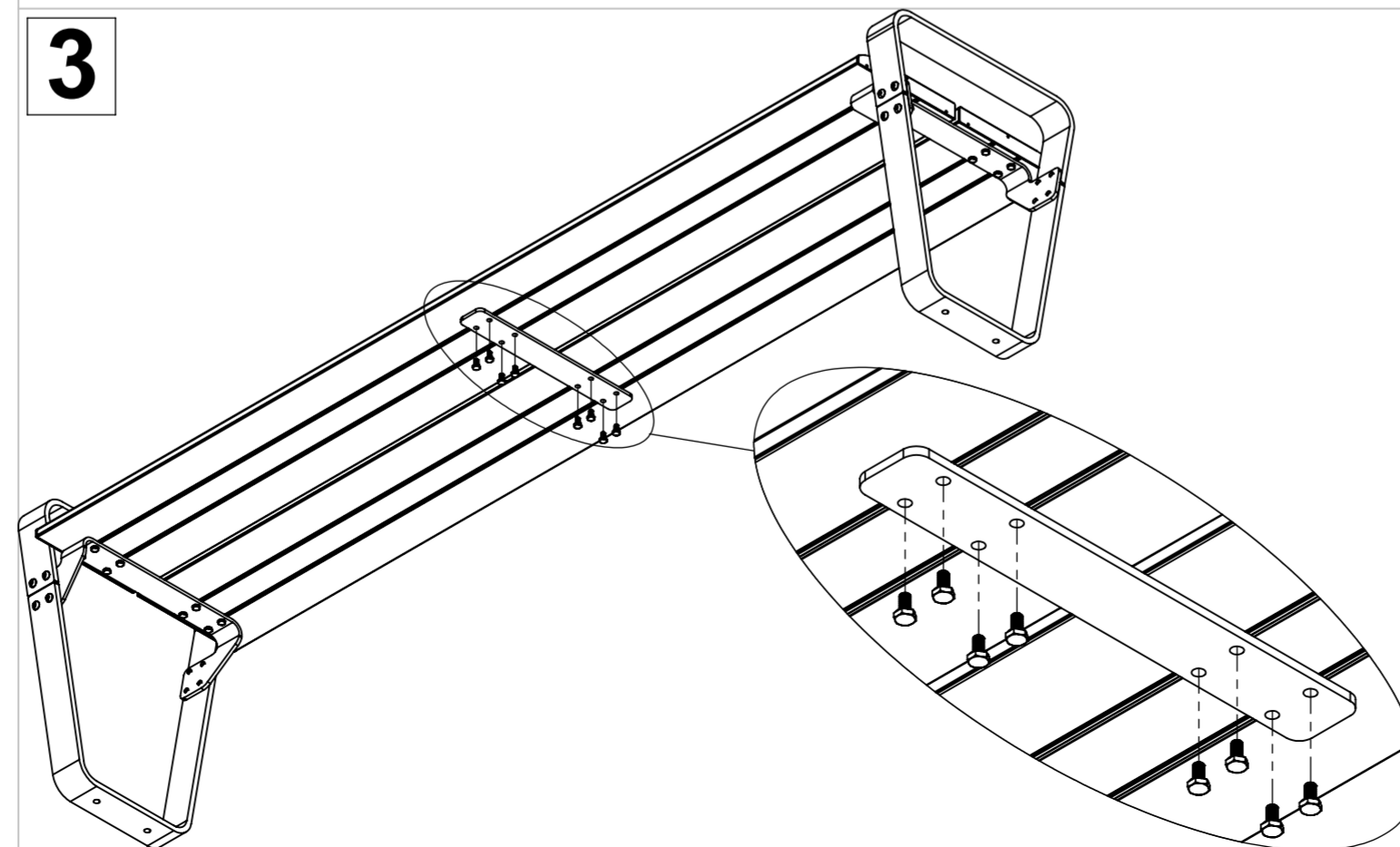

Attach the strap ④ beneath two seating plank ⑤ as illustrated.

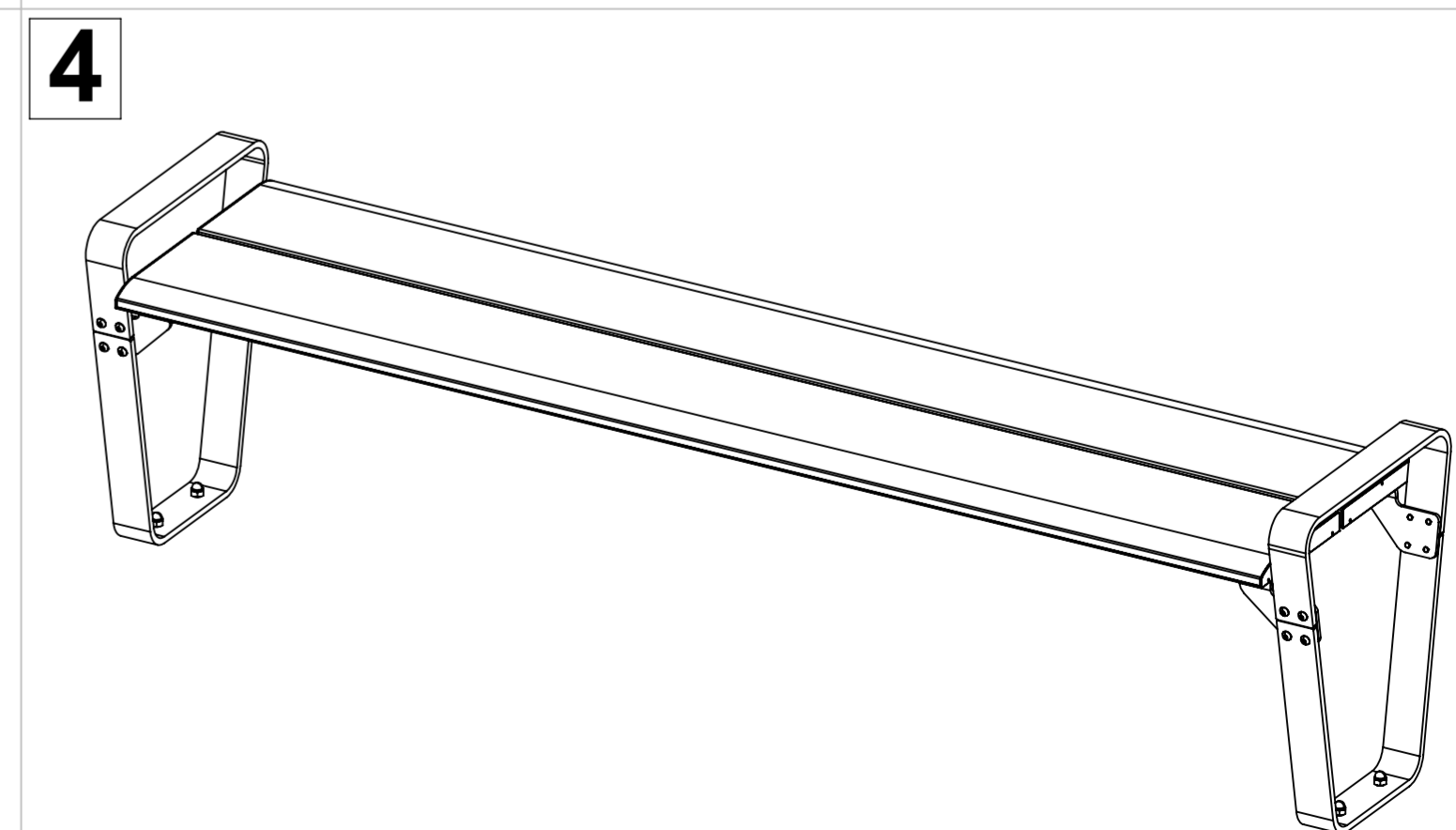

Attach the whole assembly to the ground by using M10 dyna-bolts preferably, on each side frame.