

## BIKE STANDS & BAG RACKS

### 2 Tier 3m – Bag Rack

Code: BRTF24

Get school bags off the floor and in order with the Felton Bag Rack. Easy to clean, durable and hygienic, the Felton Bag Rack is an asset in any class!



AUSTRALIAN  
MADE & OWNED



UP TO 20% MORE  
ALUMINIUM



7 YEAR  
WARRANTY



BENCHMARK  
ENGINEERING



PREMIUM  
MATERIALS



#### Key Features

- Finish: All Planks Marine Grade Anodised.
- Frames: Plain Aluminium
- Rounded tube frames for additional safety
- Customised sizes available
- Option for floor or wall fixing available
- Fully Aluminium – No rust
- Keeps bag area clean, tidy and hygienic
- Reliable and maintenance free

#### Ideal for

- Schools
- Colleges
- Gyms
- Commercial areas



#### Specifications

2 Tier 3m – Bag Rack

**Overall Plan:** 3008mm L x 600mm W x 1020mm H

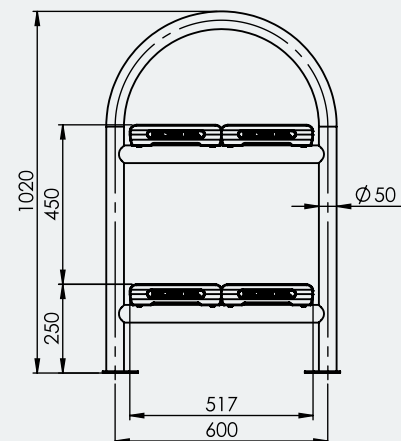
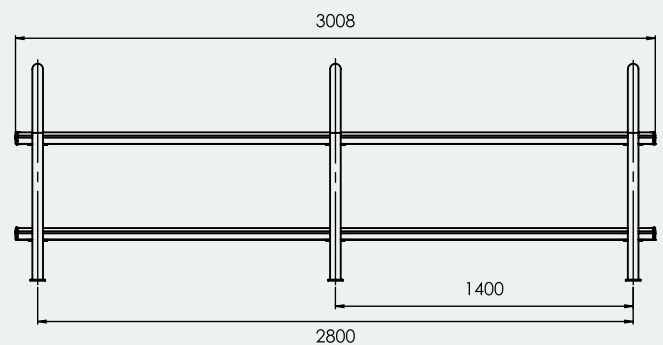

A Division of Felton International Group Pty Ltd  
ABN 17 130 687 240

