

BIKE STANDS & BAG RACKS

3 Tier 2m – Bag Rack

Code: BRTF23

Get school bags off the floor and in order with the Felton Bag Rack. Easy to clean, durable and hygienic, the Felton Bag Rack is an asset in any class!



Key Features

- Finish: All Planks Marine Grade Anodised.
- Frames: Plain Aluminium
- Rounded tube frames for additional safety
- Customised sizes available
- Option for floor or wall fixing available
- Fully Aluminium – No rust
- Keeps bag area clean, tidy and hygienic
- Reliable and maintenance free

Ideal for

- Schools
- Colleges
- Gyms
- Commercial areas



Specifications

3 Tier 2m – Bag Rack

Overall Plan: 2008mm L x 600mm W x 1470mm H

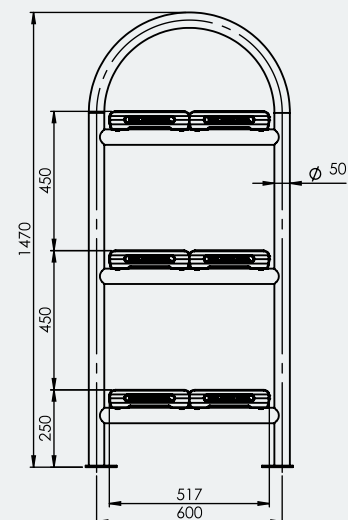
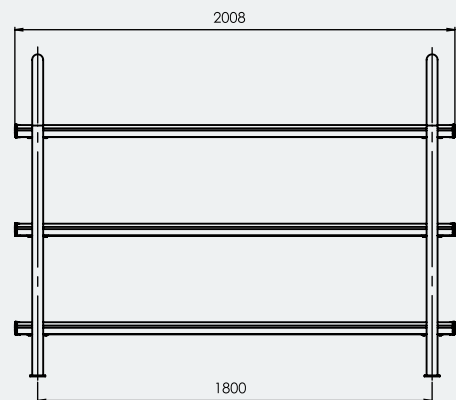

A Division of Felton International Group Pty Ltd
ABN 17 130 687 240

