



ASSEMBLY INSTRUCTIONS



**COMFORT
GRANDSTAND
3 TIER – 4 MTR**

Code: COMG3T4

THANK YOU
for choosing Felton Industries.

This product has been manufactured in Australia to the highest quality standard, guaranteeing proven quality, durability and low maintenance.



Felton Industries Pty Ltd | ABN: 17 130 687 240

felton.net.au sales@felton.net.au

1800 834 016



WARNING: This assembly required two or more people as lifting is involved. Please ensure bolts and nuts are only finger-tightened throughout assembly for flexibility in lining up components. Bolt and nuts should be securely tightened in place when instructed to do so. Please check all components are included before proceeding with the assembly

ITEM NO.	PART	QTY.
1	COMG3T4_BASE FRAME ASM	4
2	COMG3T4_TIER PLANK L4000 ASM	6
3	COMG3T4_3rd SEAT PLANK L4000 ASM	1
4	COMG3T4_BACKREST PLANK L4000 ASM	1
5	COMG3T4_AL FLAT BAR 80x6xL4000	1
6	COMG3T4_AL FLAT BAR 50x4xL1340	6
7	AS-NZS 2465 Bolt - 1/4" x 1"	120
8	AS-NZS NYLON Nut - 1/4"	120
9	AS 1112 Bolt - 3/8" x 1"	4
10	AS 1112 Nut - 3/8"	4
11	AS-FLAT WASHER - 1/2"	16
12	AS-NZS 2465 Bolt - 1/2" x 3.5"	8
13	AS-NZS NYLON Nut - 1/2"	8

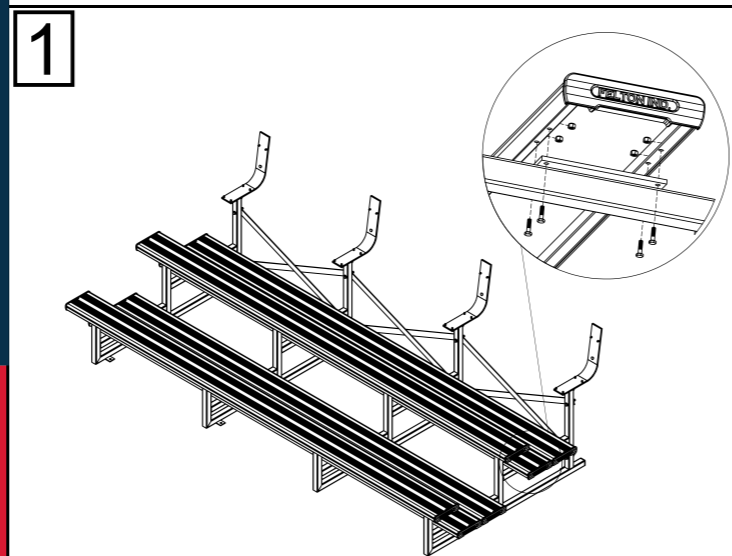
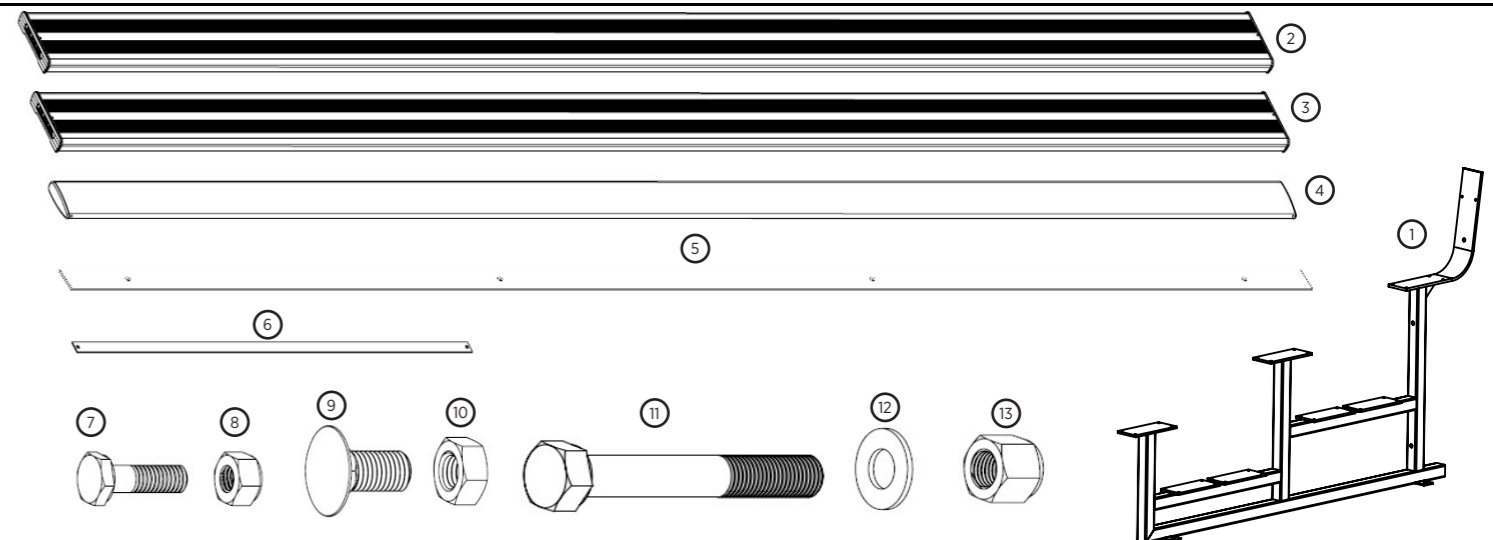

Attach six planks (2) to four base frames (1) to create tread and seat platforms by using bolts (7) and nuts (8). Note that all fixing lugs on base frames face inwards.

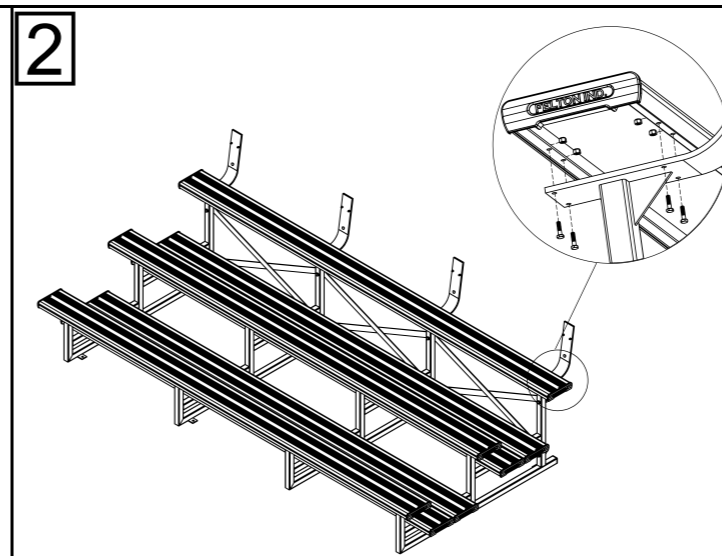

Attach 3rd seat plank (3) (with notch cut beneath) to the assembly in step 1 by using bolts (7) and nuts (8) as illustrated.

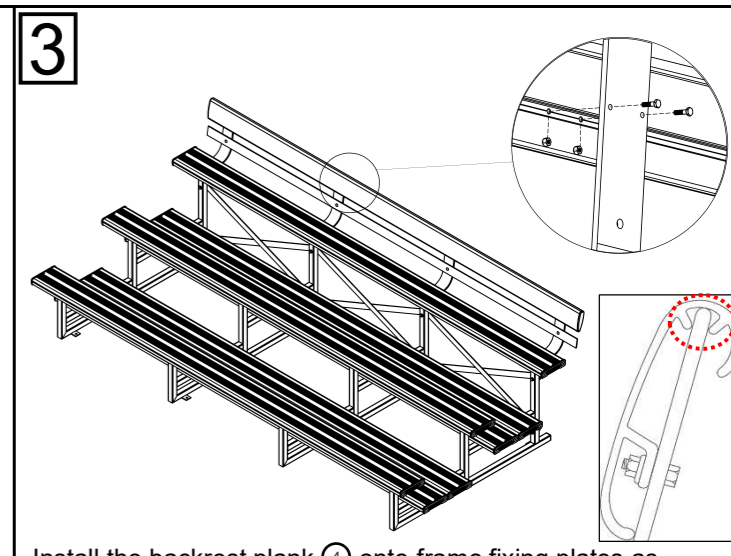

Install the backrest plank (4) onto frame fixing plates as illustrated. Fasten the backrest plank (4) with hexagonal bolts (7) and nuts (8). Ensure the fixing plates are installed in the right place on backrest plank.

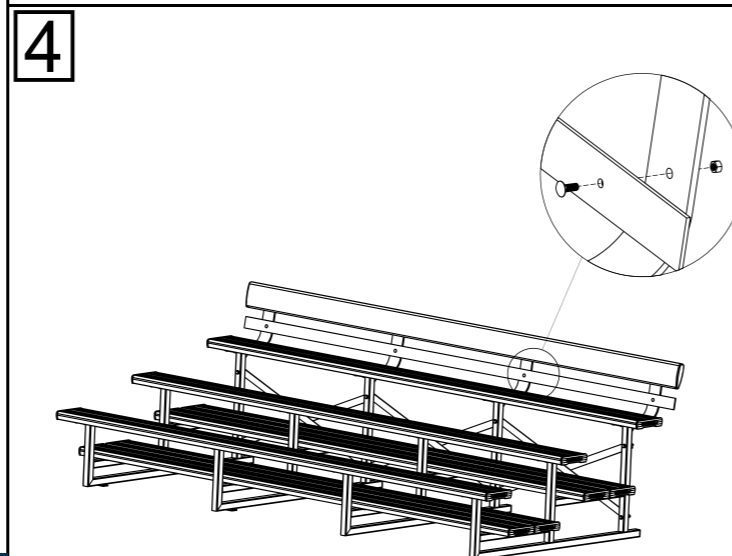

Attach the long flat bar (5) to fixing plates by using bolts (9) and nuts (10) as illustrated.

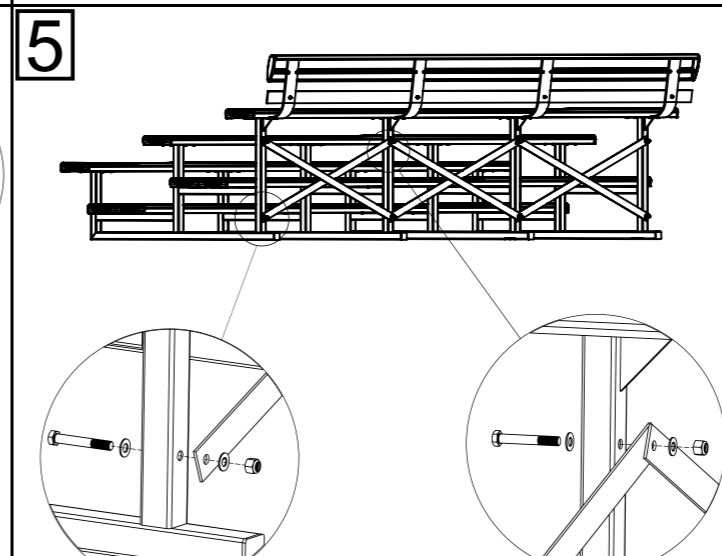

Attach six flat bars (6) to the back of base frames (1) by using bolts (11), washers (12) and nuts (13) as illustrated.

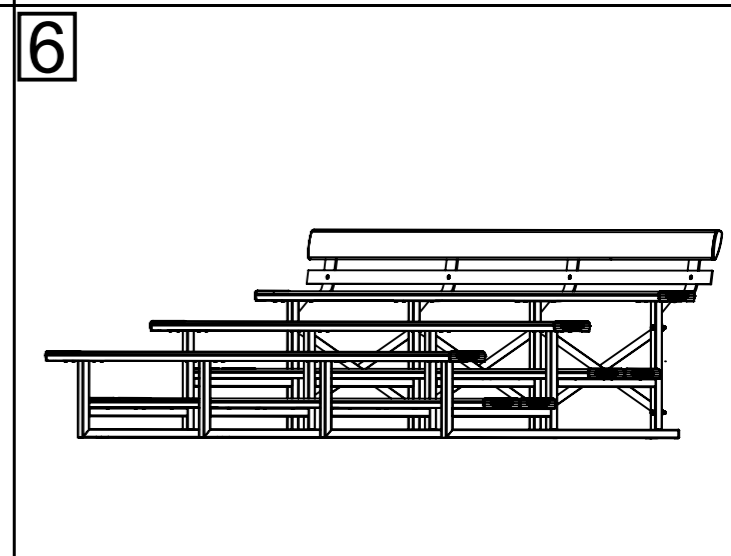

Tighten all hexagonal head bolts with spanners and appropriate tools. Then completely tighten the M12 dynabolts to attach the whole assembly firmly to the ground.