

GRANDSTAND



# SELECT 3T – 6 METRE GRANDSTAND

Code: SELG3T6



AUSTRALIAN  
MADE & OWNED



UP TO 20% MORE  
ALUMINIUM



7 YEAR  
WARRANTY



BENCHMARK  
ENGINEERING



PREMIUM  
MATERIALS

## DESCRIPTION

The select 3-Tier Grandstand is a durable, modular seating system with three elevated tiers, offering excellent views, comfort and safety. Customizable to fit various venues, it is ideal for sports, events, and recreational facilities.

## KEY FEATURES

- Enhanced Sightlines: The three-tier layout ensures clear visibility for all spectators.
- Fits up to 45 fans
- Durability: With its heavy duty aluminium, the grandstand offers a long lifespan and minimal maintenance.
- Customizable Layout: The flexible design allows it to be tailored to fit different event sizes and spaces.
- X brace enhanced safety support.
- Bolt it down or move it around
- Coloured safety end caps available in red, blue, green, purple, yellow and orange.

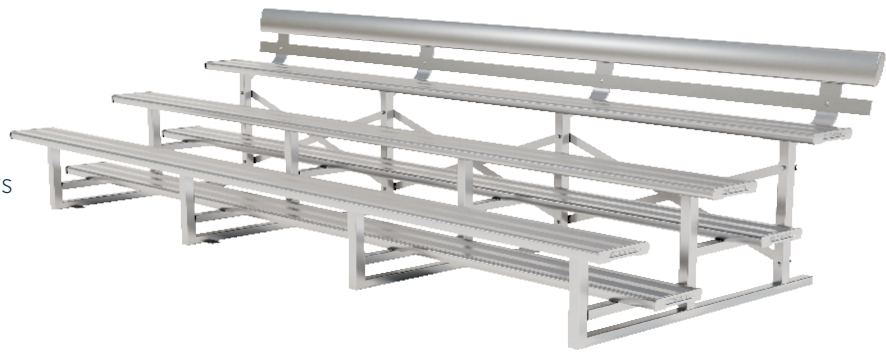

## IDEAL FOR

- Sports clubs
- Schools & Universities
- Council Grounds
- Any outdoor venue

## SPECIFICATIONS

Select 3T – 4 Metre

**Overall Plan:** 6016mmW x 1223mmH x 1655mmD

